



Datrium FIPS Object Module

FIPS 140-2 Non-Proprietary Security Policy

Document Version: 1.1

Date: 2/9/2018

Table of Contents

References	4
Acronyms and Definitions	5
1 Introduction	6
2 Tested configurations	7
3 Ports and interfaces	8
4 Cryptographic Functionality	10
4.1 Algorithms.....	10
5 Critical Security Parameters and Public Keys	13
5.1 Critical Security Parameters.....	13
5.2 Public Keys	14
5.3 CSPs and Public key access	14
6 Roles, Authentication and Services	15
7 Self-test	17
7.1 Power-On Self-tests	17
7.2 Conditional Self-Tests	18
8 Operational Environment	18
9 Mitigation of Other Attacks Policy	18

List of Tables

Table 1: NIST References	4
Table 2: Others references.....	4
Table 3: Acronyms and Definitions	5
Table 4: Security Level of Security Requirements.....	6
Table 5: Tested Configurations (B = Build Method; EC = Elliptic Curve Support). The EC column indicates support for prime curve only (P), or all NIST defined B, K, and P curves (BKP).	8
Table 6: Logical interfaces.....	9
Table 7: FIPS Approved Cryptographic Functions	12
Table 8: Non-FIPS Approved But Allowed Cryptographic Functions	12
Table 9: FIPS Non-Approved Cryptographic Functions	13
Table 10: Critical Security Parameters.....	14
Table 11: Public Keys.....	14
Table 12: Roles Supported by the Module	15
Table 13: Services and CSPs access.....	17
Table 14: Power-On Self-Test (KAT = Known answer test; PCT = Pairwise consistency test).....	18
Table 15: Conditional Self-Test	18
Table 16: Compilers	23

List of Figures

Figure 1 – Module Block Diagram.....	7
--------------------------------------	---

References

Acronym	Full Specification Name
[X9.31]	Digital Signatures Using Reversible Public Key Cryptography for the Financial Services Industry (rDSA)
[38A]	NIST, Special Publication 800-38A, <i>Recommendation for Block Cipher Modes of Operation: Methods and Techniques</i> , December, 2001
[38B]	NIST, Special Publication 800-38B, <i>Recommendation for Block Cipher Modes of Operation: The CMAC Mode for Authentication</i> , May, 2005
[38C]	NIST, Special Publication 800-38C, <i>Recommendation for Block Cipher Modes of Operation: The CCM Mode for Authentication and Confidentiality</i> , May, 2004
[38D]	NIST, Special Publication 800-38D, <i>Recommendation for Block Cipher Modes of Operation: Galois/Counter Mode (GCM) and GMAC</i> , November, 2007
[38E]	NIST, Special Publication 800-38E, <i>Recommendation for Block Cipher Modes of Operation: The XTS-AES Mode for Confidentiality on Storage Devices</i> , January, 2010
[56A]	NIST, Special Publication 800-56A, <i>Recommendation for Pair-Wise Key Establishment Schemes Using Discrete Logarithm Cryptography</i> , March, 2007
[67]	NIST Special Publication 800-67, <i>Recommendation for the Triple Data Encryption Algorithm (TDEA) Block Cipher</i> , version 1.2, July, 2011
[90A]	NIST, Special Publication 800-90A, <i>Recommendation for Random Number Generation Using Deterministic Random Bit Generators</i> , January, 2012
[108]	NIST, <i>Recommendation for Key Derivation Using Pseudorandom Functions (Revised)</i> , FIPS Publication 108, October, 2009
[180]	NIST, <i>Secure Hash Standard</i> , FIPS Publication 180-4, March, 2012
[186-2]	NIST, <i>Digital Signature Standard (DSS)</i> , FIPS Publication 186-4, July, 2013
[186-4]	NIST, <i>Digital Signature Standard (DSS)</i> , FIPS Publication 186-4, July, 2013
[197]	NIST, <i>Advanced Encryption Standard (AES)</i> , FIPS Publication 197, November 26, 2001
[198]	NIST, <i>The Keyed-Hash Message Authentication Code (HMAC)</i> , FIPS Publication 198-1, July 2008
[201]	NIST, <i>SHA-3 Standard</i> , FIPS Publication 202, August, 2015

Table 1: NIST References

<i>Other References</i>	
[FIPS140-2]	NIST, <i>Security Requirements for Cryptographic Modules</i> , May 25, 2001
[IG]	NIST, <i>Implementation Guidance for FIPS PUB 140-2 and the Cryptographic Module Validation Program</i> , last updated September 11, 2017
[PKCS#1]	<i>PKCS #1 v2.1: RSA Cryptography Standard</i> , RSA Laboratories, June 14, 2002
[SP800-131A]	<i>Transitions: Recommendation for Transitioning the Use of Cryptographic Algorithms and Key Lengths</i> , November 2015

Table 2: Others references

Acronyms and Definitions

Acronym	Definition
API	Application Programming Interface
CSP	Critical Security Parameter, see [FIPS 140-2]
HID	Human Interface Device (Microsoftism)
IC	Integrated Circuit
KAT	Known Answer Test
NVM	Non-Volatile Memory (e.g., EEPROM, Flash)
PCT	Pairwise Consistency Test
PKI	Public Key Infrastructure

Table 3: Acronyms and Definitions

1 Introduction

This document is the non-proprietary security policy for the cryptographic Datrium FIPS Object Module which implements the OpenSSL FIPS Object Module SE v2.0.12, hereafter referred to as the Module.

The Module is a software library providing a C-language application program interface (API) for use by other processes that require cryptographic functionality. The Module is classified by FIPS140-2 as a software module, multi-chip standalone module embodiment. The physical cryptographic boundary is the general purpose computer on which the module is installed. The logical cryptographic boundary of the Module is the *fipscanister* object module, a single object module file named *fipscanister.o* (Linux¹/Unix² and Vxworks³) or *fipscanister.lib* (Microsoft Windows⁴).

The Module performs no communications other than with the calling application (the process that invokes the Module services).

Note that the Datrium FIPS Object Module v2.0.12 is fully backwards compatible with all earlier revisions of the OpenSSL FIPS Object Module SE. The v2.0.12 Module incorporates support for new platforms without disturbing functionality for any previously tested platforms. The v2.0.12 Module can be used in any environment supported by the earlier revisions of the Module, and those earlier revisions remain valid.

The FIPS 140-2 security levels for the Module are as follows:

Security Requirement	Level
Cryptographic Module Specification	1
Cryptographic Module Ports and Interfaces	1
Roles, Services, and Authentication	2
Finite State Model	1
Physical Security	N/A
Operational Environment	1
Cryptographic Key Management	1
EMI/EMC	1
Self-Tests	1
Design Assurance	3
Mitigation of Other Attacks	N/A

Table 4: Security Level of Security Requirements

The Module's software version for this validation is 2.0.12. The v2.0.12 Module incorporates changes from earlier revisions of the Module to support additional platforms. The v2.0.12 Module can be used in all the environments supported by the earlier v2.0.9, v2.0.10, and v2.0.11 revisions of the Module.

¹ Linux is the registered trademark of Linus Torvalds in the U.S. and other countries.

² UNIX is a registered trademark of The Open Group.

³ Vxworks is a registered trademark owned by Wind River Systems, Inc.

⁴ Windows is a registered trademark of Microsoft Corporation in the United States and other countries.

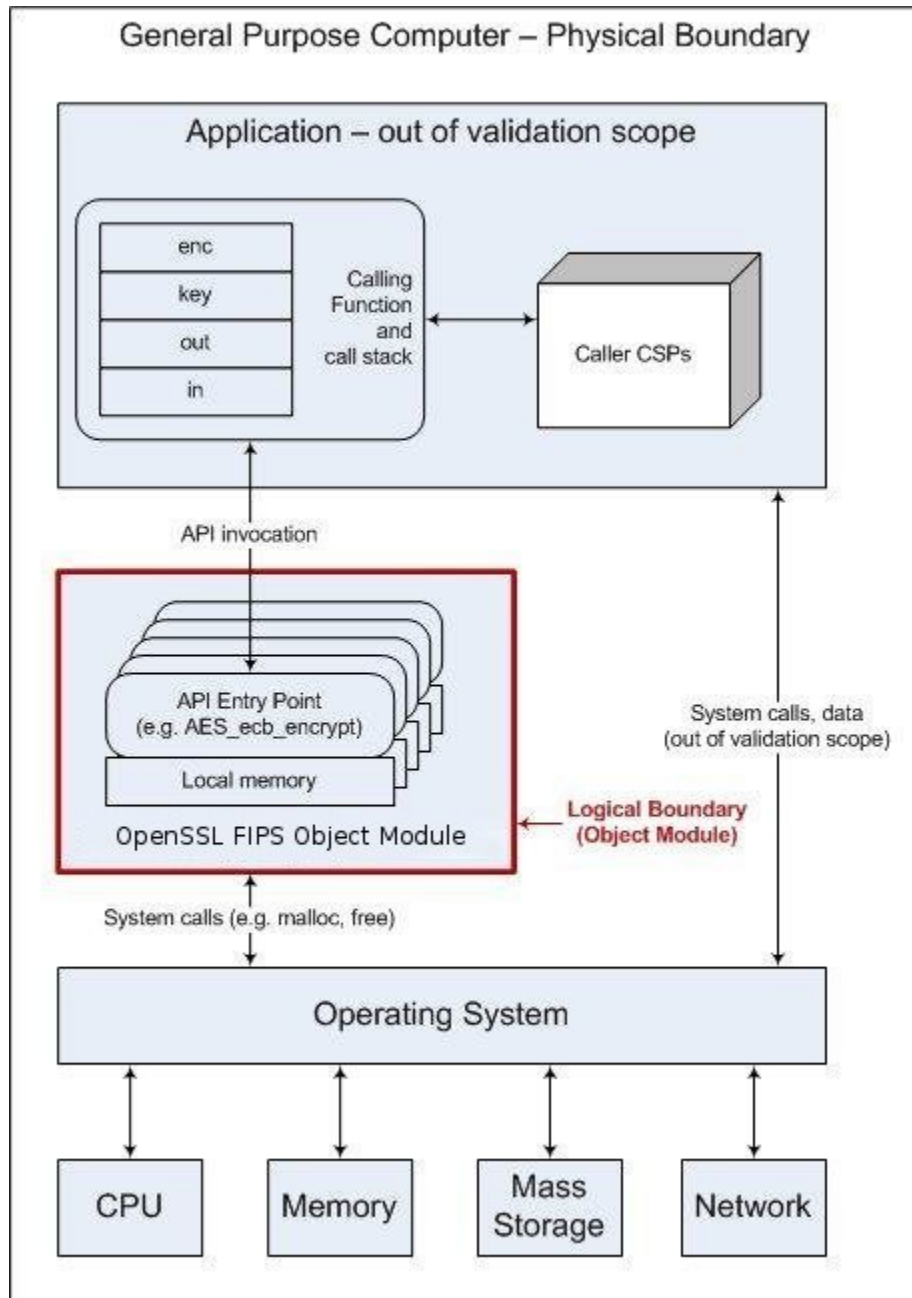

Figure 1 – Module Block Diagram

2 Tested configurations

#	Operational Environment ⁵	CPU family	Optimization (Target)	EC	B
1	TS-Linux 2.4	Arm920Tid (ARMv4)	None	BKP	U2
2	iOS 8.1 64-bit	Apple A7 (ARMv8)	None	BKP	U2
3	iOS 8.1 64-bit	Apple A7 (ARMv8)	NEON and Crypto	BKP	U2

⁵ Operational Environments 24, 25, and 26 include the hardware environment.

#	Operational Environment ⁵	CPU family	Optimization (Target)	EC	B
			Extensions		
4	VxWorks 6.9	Freescall P2020 (PPC)	None	BKP	U2
5	iOS 8.1 32-bit	Apple A7 (ARMv8)	None	BKP	U2
6	iOS 8.1 32-bit	Apple A7 (ARMv8)	NEON	BKP	U2
7	Android 5.0	Qualcomm APQ8084 (ARMv7)	None	BKP	U2
8	Android 5.0	Qualcomm APQ8084 (ARMv7)	NEON	BKP	U2
9	Android 5.0 64-bit	SAMSUNG Exynos7420 (ARMv8)	None	BKP	U2
10	Android 5.0 64-bit	SAMSUNG Exynos7420 (ARMv8)	NEON and Crypto Extensions	BKP	U2
11	VxWorks 6.7	Intel Core 2 Duo (x86)	None	BKP	U2
12	AIX 6.1 32-bit	Power 7 (PPC)	None	BKP	U2
13	AIX 6.1 64-bit	Power 7 (PPC)	None	BKP	U2
14	AIX 7.1 32-bit	Power 7 (PPC)	None	BKP	U2
15	AIX 7.1 64-bit	Power 7 (PPC)	None	BKP	U2
16	DataGravity Discovery Series OS V2.0	Intel Xeon E5-2420 (x86)	None	BKP	U2
17	DataGravity Discovery Series OS V2.0	Intel Xeon E5-2420 (x86)	AES-NI	BKP	U2
18	AIX 6.1 32-bit	Power 7 (PPC)	Optimizations	BKP	U2
19	AIX 6.1 64-bit	Power 7 (PPC)	Optimizations	BKP	U2
20	Ubuntu 12.04	Intel Xeon E5-2430L (x86)	None	BKP	U2
21	Ubuntu 12.04	Intel Xeon E5-2430L (x86)	AES-NI	BKP	U2
22	Linux 3.10	Intel Atom E3845 (x86)	None	BKP	U2
23	Linux 3.10	Intel Atom E3845 (x86)	AES-NI	BKP	U2
24	Linux 3.10 running on Datrium F12X2 Data Node	Intel Xeon E5-2618L v4 (x86-64)	AES-NI	BKP	U2
25	VMWare ESXi 6.5.0 u1 running on Datrium CN2100-SYS-1 Compute Node	Intel Xeon Gold 6148 (x86-64)	AES-NI	BKP	U2
26	Red Hat Enterprise Linux 7.3 running on Datrium CN2100-SYS-1 Compute Node	Intel Xeon Gold 6148 (x86-64)	AES-NI	BKP	U2

Table 5: Tested Configurations

(B = Build Method; EC = Elliptic Curve Support). The EC column indicates support for prime curve only (P), or all NIST defined B, K, and P curves (BKP).

See Appendix A for additional information on build method and optimizations. See Appendix C for a list of the specific compilers used to generate the Module for the respective operational environments.

3 Ports and interfaces

The physical ports of the Module are the same as the computer system on which it is executing. The logical interface is a C-language application program interface (API).

Logical Interface Type	Description
Control input	API entry point and corresponding stack parameters
Data input	API entry point data input stack parameters
Status output	API entry point return values and status stack parameters
Data output	API entry point data output stack parameters

Table 6: Logical interfaces

As a software module, control of the physical ports is outside module scope. However, when the module is performing self-tests, or is in an error state, all output on the logical data output interface is inhibited. The module is single-threaded and in error scenarios returns only an error value (no data output is returned).

4 Cryptographic Functionality

4.1 Algorithms

The Module supports only a FIPS 140-2 Approved mode. Table 7 and Table 8 list the Approved and Non-Approved but Allowed algorithms, respectively.

Function	Algorithm	Options	Cert #
Random Number Generation; Symmetric key generation	[SP 800-90] DRBG ⁶ Prediction resistance supported for all variations	Hash DRBG HMAC DRBG, no reseed CTR DRBG (AES), no derivation function	607
			723
			845
			1027
			1953
Encryption, Decryption and CMAC	[SP 800-67]	3-Key TDES ECB, TCBC, TCFB, TOFB; CMAC generate and verify	1780
			1853
			1942
			2086
			2635
	[FIPS 197] AES	128/192/256 ECB, CBC, OFB, CFB 1, CFB 8, CFB 128, CTR, XTS; CCM; GCM; CMAC generate and verify	3090
	[SP 800-38B] CMAC		3264
	[SP 800-38C] CCM		3451
	[SP 800-38D] GCM		3751
	[SP 800-38E] XTS		5178
Message Digests	[FIPS 180-3]	SHA-1, SHA-2 (224, 256, 384, 512)	2553
			2702
			2847
			3121
			4182
Keyed Hash	[FIPS 198] HMAC	SHA-1, SHA-2 (224, 256, 384, 512)	1937
			2063
			2197
			2452
			3434
Digital Signature and Asymmetric Key Generation	[FIPS 186-2] RSA	GenKey9.31, SigGen9.31, SigGenPKCS1.5, SigGenPSS, SigVer9.31, SigVerPKCS1.5, SigVerPSS (2048/3072/4096 with all SHA-2 sizes)	1581
			1664
			1766
	[FIPS 186-4] DSA	PQG Gen, PQG Ver, Key Pair Gen, Sig Gen, Sig Ver (1024/2048/3072 with all SHA-2 sizes)	1928
			2780
			896
[FIPS 186-2] ECDSA	PKG: CURVES(P-224 P-256 P-384 P-521 K-233 K-283 K-409 K-571 B-233 B-283 B-409 B-571) PKV: CURVES(P-192 P-224 P-256 P-384	933	
		970	
		1040	
		1343	
			558
			620
			698
			801

⁶ For all DRBGs the "supported security strengths" is just the highest supported security strength per [SP800-90] and [SP800-57].

Function	Algorithm	Options	Cert #
		P-521 K-163 K-233 K-283 K-409 K-571 B-163 B-233 B-283 B-409 B-571)	1342
		PKG: CURVES(P-224 P-256 P-384 P-521) PKV: CURVES(P-192 P-224 P-256 P-384 P-521)	
	[FIPS 186-4] ECDSA	PKG: CURVES(P-224 P-256 P-384 P-521 K-233 K-283 K-409 K-571 B-233 B-283 B-409 B-571 ExtraRandomBits TestingCandidates) PKV: CURVES(ALL-P ALL-K ALL-B) SigGen: CURVES(P-224: (SHA-224, 256, 384, 512) P-256: (SHA-224, 256, 384, 512) P-384: (SHA-224, 256, 384, 512) P-521: (SHA-224, 256, 384, 512) K-233: (SHA-224, 256, 384, 512) K-283: (SHA-224, 256, 384, 512) K-409: (SHA-224, 256, 384, 512) K-571: (SHA-224, 256, 384, 512) B-233: (SHA-224, 256, 384, 512) B-283: (SHA-224, 256, 384, 512) B-409: (SHA-224, 256, 384, 512) B-571: (SHA-224, 256, 384,512)) SigVer: CURVES(P-192: (SHA-1, 224, 256, 384, 512) P-224: (SHA-1, 224, 256, 384, 512) P-256: (SHA-1, 224, 256, 384, 512) P-384: (SHA-1, 224, 256, 384, 512) P-521: (SHA-1, 224, 256, 384, 512) K-163: (SHA-1, 224, 256, 384, 512) K-233: (SHA-1, 224, 256, 384, 512) K-283: (SHA-1, 224, 256, 384, 512) K-409: (SHA-1, 224, 256, 384, 512) K-571: (SHA-1, 224, 256, 384, 512 B-163: (SHA-1, 224, 256, 384, 512) B-233: (SHA-1, 224, 256, 384, 512) B-283: (SHA-1, 224, 256, 384, 512) B-409: (SHA-1, 224, 256, 384, 512) B-571: (SHA-1, 224, 256, 384, 512))	558 620 698 801 1342
		PKG: CURVES(P-224 P-256 P-384 P-521) PKV: CURVES(ALL-P) SigGen: CURVES(P-224: (SHA-224, 256, 384, 512) P-256: (SHA-224, 256, 384, 512) P-384: (SHA-224, 256, 384, 512) P-521: (SHA-224, 256, 384, 512)) SigVer: CURVES(P-192: (SHA-1, 224, 256, 384, 512) P-224: (SHA-1, 224, 256, 384, 512) P-256: (SHA-1, 224, 256, 384, 512) P-384: (SHA-1, 224, 256, 384, 512) P-521: (SHA-1, 224, 256, 384, 512))	

Function	Algorithm	Options	Cert #
ECC CDH (KAS)	[SP 800-56A] (§5.7.1.2)	All NIST defined B, K and P curves except sizes 163 and 192	372 472 534 699 1680
		All NIST defined P curves	

Table 7: FIPS Approved Cryptographic Functions

The Module supports only NIST defined curves for use with ECDSA and ECC CDH. The Module supports two operational environment configurations for elliptic curve; NIST prime curve only (listed in Table 2 with the EC column marked "P") and all NIST defined curves (listed in Table 2 with the EC column marked "BKP").

Category	Algorithm	Description
Key Agreement	EC DH	Non-compliant (untested) DH scheme using elliptic curve, supporting all NIST defined B, K and P curves. Key agreement is a service provided for calling process use, but is not used to establish keys into the Module.
Key Encryption, Decryption	RSA	The RSA algorithm may be used by the calling application for encryption or decryption of keys. No claim is made for SP 800-56B compliance, and no CSPs are established into or exported out of the module using these services.

Table 8: Non-FIPS Approved But Allowed Cryptographic Functions

The Module implements the following services which are Non-Approved per the SP 800-131A transition:

Function	Algorithm	Options
Random Number Generation; Symmetric key generation	[ANS X9.31] RNG	AES 128/192/256
Random Number Generation; Symmetric key generation	[SP 800-90] DRBG	Dual EC DRBG
Digital Signature and Asymmetric Key Generation	[FIPS 186-2] RSA	GenKey9.31, SigGen9.31, Sig Gen PKCS1.5, Sig Gen PSS (1024/1536 with all SHA sizes, 2048/3072/4096 with SHA-1)
	[FIPS 186-2] DSA	PQG Gen, Key Pair Gen, Sig Gen (1024 with all SHA sizes, 2048/3072 with SHA-1)
	[FIPS 186-4] DSA	PQG Gen, Key Pair Gen, Sig Gen (1024 with all SHA sizes, 2048/3072 with SHA-1)
	[FIPS 186-2] ECDSA	PKG: CURVES(P-192 K-163 B-163)

Function	Algorithm	Options
		SIG(gen): CURVES(P-192 P-224 P-256 P-384 P-521 K-163 K-233 K-283 K-409 K-571 B-163 B-233 B-283 B-409 B-571)
	[FIPS 186-4] ECDSA	PKG: CURVES(P-192 K-163 B-163) Sig Gen: CURVES(P-192: (SHA-1, 224, 256, 384, 512) P-224:(SHA-1) P-256:(SHA-1) P-384: (SHA-1) P-521:(SHA-1) K-163: (SHA-1, 224, 256, 384, 512) K-233:(SHA-1) K-283:(SHA-1) K-409:(SHA-1) K-571:(SHA-1) B-163: (SHA-1, 224, 256, 384, 512) B-233:(SHA-1) B-283: (SHA-1) B-409:(SHA-1) B-571:(SHA-1))
ECC CDH (CVL)	[SP 800-56A] (§5.7.1.2)	All NIST Recommended B, K and P curves sizes 163 and 192

Table 9: FIPS Non-Approved Cryptographic Functions

X9.31 RNG is Non-Approved effective December 31, 2015, per the CMVP Notice "X9.31 RNG transition, December 31, 2015".

These algorithms shall not be used when operating in the FIPS Approved mode of operation.

EC DH Key Agreement provides a maximum of 256 bits of security strength. RSA Key Wrapping provides a maximum of 256 bits of security strength.

The Module requires an initialization sequence (see IG 9.5): the calling application invokes `FIPS_mode_set()`⁷, which returns a "1" for success and "0" for failure. If `FIPS_mode_set()` fails then all cryptographic services fail from then on. The application can test to see if FIPS mode has been successfully performed.

The Module is a cryptographic engine library, which can be used only in conjunction with additional software. Aside from the use of the NIST defined elliptic curves as trusted third party domain parameters, all other FIPS 186-3 assurances are outside the scope of the Module, and are the responsibility of the calling process.

5 Critical Security Parameters and Public Keys

5.1 Critical Security Parameters

All CSPs used by the Module are described in this section. All usage of these CSPs is described in the services detailed in Section 4. The CSP names are generic, corresponding to API parameter data structures.

CSP	Description/Usage
RSA SGK	RSA (1024 to 16384 bits) signature generation key
RSA KDK	RSA (1024 to 16384 bits) key decryption (private key transport) key
DSA SGK	[FIPS 186-4] DSA (1024/2048/3072) signature generation key or [FIPS 186-2] DSA (1024) signature generation key
ECDSA SGK	ECDSA (All NIST defined B, K, and P curves) signature generation key
EC DH Private	EC DH (All NIST defined B, K, and P curves) private key agreement key.

⁷ The function call in the Module is `FIPS_module_mode_set()` which is typically used by an application via the `FIPS_mode_set()` wrapper function.

CSP	Description/Usage
AES EDK	AES (128/192/256) encrypt / decrypt key
AES CMAC	AES (128/192/256) CMAC generate / verify key
AES GCM	AES (128/192/256) encrypt / decrypt / generate / verify key
AES XTS	AES (256/512) XTS encrypt / decrypt key
TDES EDK	TDES (3-Key) encrypt / decrypt key
TDES CMAC	TDES (3-Key) CMAC generate / verify key
HMAC Key	Keyed hash key (160/224/256/384/512)
Hash_DRBG CSPs	V (440/888 bits) and C (440/888 bits), entropy input (length dependent on security strength)
HMAC_DRBG CSPs	V (160/224/256/384/512 bits) and Key (160/224/256/384/512 bits), entropy input (length dependent on security strength)
CTR_DRBG CSPs	V (128 bits) and Key (AES 128/192/256), entropy input (length dependent on security strength)
CO-AD-Digest	Pre-calculated HMAC-SHA-1 digest used for Crypto Officer role authentication
User-AD-Digest	Pre-calculated HMAC-SHA-1 digest used for User role authentication

Table 10: Critical Security Parameters

Authentication data is loaded into the module during the module build process, performed by an authorized operator (Crypto Officer), and otherwise cannot be accessed.

The module does not output intermediate key generation values.

5.2 Public Keys

Key	Description/Usage
RSA SVK	RSA (1024 to 16384 bits) signature verification public key
RSA KEK	RSA (1024 to 16384 bits) key encryption (public key transport) key
DSA SVK	[FIPS 186-4] DSA (1024/2048/3072) signature verification key
ECDSA SVK	ECDSA (All NIST defined B, K and P curves) signature verification key
EC DH Public	EC DH (All NIST defined B, K and P curves) public key agreement key.

Table 11: Public Keys

5.3 CSPs and Public key access

For all CSPs and Public Keys:

- **Storage:** RAM, associated to entities by memory location. The Module stores DRBG state values for the lifetime of the DRBG instance. The module uses CSPs passed in by the calling application on the stack. The Module does not store any CSP persistently (beyond the lifetime of an API call), with the exception of DRBG state values used for the Modules' default key generation service.
- **Generation:** The Module implements SP 800-90 compliant DRBG services for creation of symmetric keys, and for generation of DSA, elliptic curve, and RSA keys as shown in Table 4a. The calling application is responsible for storage of generated keys returned by the module.

- **Entry:** All CSPs enter the Module's logical boundary in plaintext as API parameters, associated by memory location. However, none cross the physical boundary.
- **Output:** The Module does not output CSPs, other than as explicit results of key generation services. However, none cross the physical boundary.
- **Destruction:** Zeroization of sensitive data is performed automatically by API function calls for temporarily stored CSPs. In addition, the module provides functions to explicitly destroy CSPs related to random number generation services. The calling application is responsible for parameters passed in and out of the module.

Private and secret keys as well as seeds and entropy input are provided to the Module by the calling application, and are destroyed when released by the appropriate API function calls. Keys residing in internally allocated data structures (during the lifetime of an API call) can only be accessed using the Module defined API. The operating system protects memory and process space from unauthorized access. Only the calling application that creates or imports keys can use or export such keys. All API functions are executed by the invoking calling application in a non-overlapping sequence such that no two API functions will execute concurrently. An authorized application as user (Crypto-Officer and User) has access to all key data generated during the operation of the Module.

In the event Module power is lost and restored the calling application must ensure that any AES-GCM keys used for encryption or decryption are re-distributed.

Module users (the calling applications) shall use entropy sources that meet the security strength required for the random number generation mechanism as shown in [SP 800-90] Table 2 (Hash_DRBG, HMAC_DRBG), Table 3 (CTR_DRBG) and Table 4 (Dual_EC_DRBG). This entropy is supplied by means of callback functions. Those functions must return an error if the minimum entropy strength cannot be met.

6 Roles, Authentication and Services

The Module implements the required User and Crypto Officer roles and requires authentication for those roles. Only one role may be active at a time and the Module does not allow concurrent operators. The User or Crypto Officer role is assumed by passing the appropriate password to the *FIPS_module_mode_set()* function. The password values may be specified at build time and must have a minimum length of 16 characters. Any attempt to authenticate with an invalid password will result in an immediate and permanent failure condition rendering the Module unable to enter the FIPS mode of operation, even with subsequent use of a correct password.

Authentication data is loaded into the Module during the Module build process, performed by the Crypto Officer, and otherwise cannot be accessed.

Since minimum password length is 16 characters, the probability of a random successful authentication attempt in one try is a maximum of $1/256^{16}$, or less than $1/10^{38}$. The Module permanently disables further authentication attempts after a single failure, so this probability is independent of time.

Both roles have access to all of the services provided by the Module.

Role ID	Role Description
CO	Cryptographic Officer – Installation of the Module on the host computer system and calling of any API functions.
User	User - Loading the Module and calling any of the API functions.

Table 12: Roles Supported by the Module

All services implemented by the Module are listed below, along with a description of service CSP access.

Service	Role	Description
Initialize	User, CO	Module initialization. Does not access CSPs.
Self-test	User, CO	Perform self-tests (<i>FIPS_selftest</i>). Does not access CSPs.
Show status	User, CO	Functions that provide module status information: <ul style="list-style-type: none"> • Version (as unsigned long or const char *) • FIPS Mode (Boolean) Does not access CSPs.
Zeroize	User, CO	Functions that destroy CSPs: <ul style="list-style-type: none"> • <code>fips_drbg_uninstantiate</code>: for a given DRBG context, overwrites DRBG CSPs (Hash_DRBG CSPs, HMAC_DRBG CSPs, CTR_DRBG CSPs) All other services automatically overwrite CSPs stored in allocated memory. Stack cleanup is the responsibility of the calling application.
Random number generation	User, CO	Used for random number and symmetric key generation. <ul style="list-style-type: none"> • Seed or reseed a DRBG instance • Determine security strength of a DRBG instance • Obtain random data Uses and updates Hash_DRBG CSPs, HMAC_DRBG CSPs, CTR_DRBG CSPs
Asymmetric key generation	User, CO	Used to generate DSA, ECDSA and RSA keys: RSA SGK, RSA SVK; DSA SGK, DSA SVK; ECDSA SGK, ECDSA SVK There is one supported entropy strength for each mechanism and algorithm type, the maximum specified in SP800-90
Symmetric encrypt/decrypt	User, CO	Used to encrypt or decrypt data. Executes using AES EDK, TDES EDK (passed in by the calling process).
Symmetric digest	User, CO	Used to generate or verify data integrity with CMAC. Executes using AES CMAC, TDES CMAC (passed in by the calling process).
Message digest	User, CO	Used to generate a SHA-1 or SHA-2 message digest. Does not access CSPs.
Keyed Hash	User, CO	Used to generate or verify data integrity with HMAC. Executes using HMAC Key (passed in by the calling process).
Key transport ⁸	User, CO	Used to encrypt or decrypt a key value on behalf of the calling process (does not establish keys into the module). Executes using RSA KDK, RSA KEK (passed in by the calling process).
Key agreement	User, CO	Used to perform key agreement primitives on behalf of the calling process (does not establish keys into the

⁸ "Key transport" can refer to a) moving keys in and out of the module or b) the use of keys by an external application. The latter definition is the one that applies to the OpenSSL FIPS Object Module SE.

Service	Role	Description
		module). Executes using EC DH Private, EC DH Public (passed in by the calling process).
Digital signature	User, CO	Used to generate or verify RSA, DSA or ECDSA digital signatures. Executes using RSA SGK, RSA SVK; DSA SGK, DSA SVK; ECDSA SGK, ECDSA SVK (passed in by the calling process).
Utility	User, CO	Miscellaneous helper functions. Does not access CSPs.

Table 13: Services and CSPs access

7 Self-test

7.1 Power-On Self-tests

The Module performs the self-tests listed below in Table 14 on invocation of Initialize or Self-test.

Test Target	Type	Description
Software integrity	KAT	HMAC-SHA-1
AES	KAT	Separate encrypt and decrypt, ECB mode, 128 bit key length
AES CMAC	KAT	Sign and verify CBC mode, 128, 192, 256 key lengths
AES CCM	KAT	Separate encrypt and decrypt, 192 key length
AES GCM	KAT	Separate encrypt and decrypt, 256 key length
AES XTS	KAT	128, 256 bit key sizes to support either the 256-bit key size (for XTS-AES-128) or the 512-bit key size (for XTS-AES-256)
Triple-DES	KAT	Separate encrypt and decrypt, ECB mode, 3-Key
Triple-DES CMAC	KAT	CMAC generate and verify, CBC mode, 3-Key
DRBG	KAT	Performs a fixed input KAT with the following configuration: <ul style="list-style-type: none"> CTR_DRBG: AES, 256 bit with and without derivation function HASH_DRBG: SHA256 HMAC_DRBG: SHA256 Dual_EC_DRBG: P-256 and SHA256 Dual_EC_DRBG: P-256 and SHA256
DSA	PCT	Sign and verify using 2048 bit key, SHA-384
ECDSA	PCT	Keygen, sign, verify using P-224, K-233 and SHA512. The K-233 self-test is not performed for operational environments that support prime curve only (see Table 2).
RSA	KAT	Sign and verify using 2048 bit key, SHA-256, PKCS#1
ECC CDH	KAT	Shared secret calculation per SP 800-56A §5.7.1.2, IG 9.6
HMAC	KAT	One KAT per SHA1, SHA224, SHA256, and SHA512. Per IG. 9.3, this testing covers the SHA POST requirements.

Table 14: Power-On Self-Test (KAT = Known answer test; PCT = Pairwise consistency test)

The Module is installed using one of the set of instructions in Appendix A, as appropriate for the target system. The HMAC-SHA-1 of the Module distribution file as tested by the CMT Laboratory and listed in Appendix A is verified during installation of the Module file as described in Appendix A.

The `FIPS_mode_set()`⁹ function performs all power-up self-tests listed above with no operator intervention required, returning a "1" if all power-up self-tests succeed, and a "0" otherwise. If any component of the power-up self-test fails an internal flag is set to prevent subsequent invocation of any cryptographic function calls.

The module will only enter the FIPS Approved mode if the module is reloaded and the call to `FIPS_mode_set()`⁹ succeeds.

The power-up self-tests may also be performed on-demand by calling `FIPS_selftest()`, which returns a "1" for success and "0" for failure. Interpretation of this return code is the responsibility of the calling application.

7.2 Conditional Self-Tests

The Module also implements the following conditional tests:

Test Target	Description
DRBG	Tested as required by [SP800-90] Section 11
DRBG	FIPS 140-2 continuous test for stuck fault
DSA	Pairwise consistency test on each generation of a key pair
ECDSA	Pairwise consistency test on each generation of a key pair
RSA	Pairwise consistency test on each generation of a key pair

Table 15: Conditional Self-Test

In the event of a DRBG self-test failure the calling application must unstantiate and re-instantiate the DRBG per the requirements of [SP 800-90]; this is not something the Module can do itself.

Pairwise consistency tests are performed for both possible modes of use, e.g. Sign/Verify and Encrypt/Decrypt.

The Module supports two operational environment configurations for elliptic curve: NIST prime curves only (listed in Table 2 with the EC column marked "P") and all NIST defined curves (listed in Table 2 with the EC column marked "BKP").

8 Operational Environment

The tested operating systems segregate user processes into separate process spaces. Each process space is logically separated from all other processes by the operating system software and hardware.

The Module functions entirely within the process space of the calling application, and implicitly satisfies the FIPS 140-2 requirement for a single user mode of operation.

9 Mitigation of Other Attacks Policy

The Module is not designed to mitigate against attacks which are outside of the scope of FIPS 140-2.

⁹ `FIPS_mode_set()` calls Module function `FIPS_module_mode_set()`

Appendix A – Installation and Usage Guidance

The test platforms represent different combinations of installation instructions. For each platform there is a build system, the host providing the build environment in which the installation instructions are executed, and a target system on which the generated object code is executed. The build and target systems may be the same type of system or even the same device, or may be different systems – the Module supports cross-compilation environments.

Each of these command sets are relative to the top of the directory containing the uncompressed and expanded contents of the distribution files `openssl-fips-2.0.12.tar.gz` (all NIST defined curves as listed in Table 2 with the EC column marked "BKP") or `openssl-fips-ecp-2.0.12.tar.gz` (NIST prime curves only as listed in Table 2 with the EC column marked "P"). The command sets are:

```
U1:
    ./config no-asm
    make
    make install

U2:
    ./config
    make
    make install

W1:
    ms\do_fips no-asm

W2:
    ms\do_fips

C1:
    c6x/do_fips
```

Installation instructions

1. Download and copy the distribution file to the build system.
These files can be downloaded from <http://www.openssl.org/source/>.
2. Verify the HMAC-SHA-1 digest of the distribution file; see Appendix B. An independently acquired FIPS 140-2 validated implementation of SHA-1 HMAC must be used for this digest verification. Note that this verification can be performed on any convenient system and not necessarily on the specific build or target system.
Alternatively, a copy of the distribution on physical media can be obtained from OSF¹⁰.
3. Unpack the distribution

```
gunzip -c openssl-fips-2.0.12.tar.gz | tar xf -cd openssl-fips-2.0.12
```

or

```
gunzip -c openssl-fips-ecp-2.0.12.tar.gz | tar xf
-cd openssl-fips-ecp-2.0.12
```
4. Execute one of the installation command sets U1, W1, U2, W2, C1 as shown above. No other command sets shall be used.

¹⁰ For some prospective users the acquisition, installation, and configuration of a suitable FIPS 140-2 validated product may not be convenient. OSF will on request mail a CD containing the source code distribution, via USPS or international post. A distribution file received by that means need not be verified by a FIPS 140-2 validated implementation of HMAC-SHA-1. For instructions on requesting this CD see <http://openssl.com/fips/verify.html>.

5. The resulting *fipsanister.o* or *fipsanister.lib* file is now available for use.
6. The calling application enables FIPS mode by calling the `FIPS_mode_set()`¹¹ function.

Note that failure to use one of the specified commands sets exactly as shown will result in a module that cannot be considered compliant with FIPS 140-2.

Linking the Runtime Executable Application

Note that applications interfacing with the FIPS Object Module are outside of the cryptographic boundary. When linking the application with the FIPS Object Module two steps are necessary:

1. The HMAC-SHA-1 digest of the FIPS Object Module file must be calculated and verified against the installed digest to ensure the integrity of the FIPS object module.
2. A HMAC-SHA1 digest of the FIPS Object Module must be generated and embedded in the FIPS Object Module for use by the `FIPS_mode_set()`¹¹ function at runtime initialization.

The `fips_standalone_sha1` command can be used to perform the verification of the FIPS Object Module and to generate the new HMAC-SHA-1 digest for the runtime executable application. Failure to embed the digest in the executable object will prevent initialization of FIPS mode.

At runtime the `FIPS_mode_set()`¹¹ function compares the embedded HMAC-SHA-1 digest with a digest generated from the FIPS Object Module object code. This digest is the final link in the chain of validation from the original source to the runtime executable application file.

Optimization

The “asm” designation means that assembler language optimizations were enabled when the binary code was built, “no-asm” means that only C language code was compiled.

For OpenSSL with x86 there are three possible optimization levels:

1. No optimization (plain C)
2. SSE2 optimization
3. AES-NI+PCLMULQDQ+SSSE3 optimization

Other theoretically possible combinations (e.g. AES-NI only, or SSE3 only) are not addressed individually, so that a processor which does not support all three of AES-NI, PCLMULQDQ, and SSSE3 will fall back to SSE2 optimization.

For more information, see:

- <http://www.intel.com/support/processors/sb/CS-030123.htm?wapkw=sse2>
- <http://software.intel.com/en-us/articles/intel-advanced-encryption-standard-instructions-aes-ni/?wapkw=aes-ni>

For OpenSSL with ARM there are two possible optimization levels:

1. Without NEON
2. With NEON (ARM7 only)

For more information, see <http://www.arm.com/products/processors/technologies/neon.php>

¹¹ `FIPS_mode_set()` calls the Module function `FIPS_module_mode_set()`

Appendix B – Controlled Distribution File Fingerprint

The Datrium FIPS Object Module v2.0.12 consists of the FIPS Object Module (the *fipscanister.o* or *fipscanister.lib* contiguous unit of binary object code) generated from the specific source files.

For all NIST defined curves (listed in Table 2 with the EC column marked "BKP") the source files are in the specific special OpenSSL distribution `openssl-fips-2.0.12.tar.gz` with HMAC-SHA-1 digest of

```
86ec30179f1bfb2edde4ababf0fb519ba7380b69
```

located at www.openssl.org/source/openssl-fips-2.0.12.tar.gz.

The `openssl` command from a version of OpenSSL that incorporates a previously validated version of the module may be used:

```
openssl sha1 -hmac etaonrishdlcupfm openssl-fips-2.0.12.tar.gz
```

For NIST prime curves only (listed in Table 2 with the EC column marked "P") the source files are in the specific special OpenSSL distribution `openssl-fips-ecp-2.0.12.tar.gz` with HMAC-SHA-1 digest of

```
3da3e6d610378ad4b6ee2638a141c17cb3a2aabf
```

located at <http://www.openssl.org/source/openssl-fips-ecp-2.0.12.tar.gz>. Note this is from the previous revision of the FIPS Object Module as no modifications relevant to NIST prime curves only were introduced in revision 2.0.12.

The set of files specified in this tar file constitutes the complete set of source files of this module. There shall be no additions, deletions, or alterations of this set as used during module build. The OpenSSL distribution tar file (and patch file if used) shall be verified using the above HMAC-SHA-1 digest(s).

The arbitrary 16 byte key of:

```
65 74 61 6f 6e 72 69 73 68 64 6c 63 75 70 66 6d
```

(equivalent to the ASCII string "etaonrishdlcupfm") is used to generate the HMAC-SHA-1 value for the FIPS Object Module integrity check.

The functionality of all earlier revisions of the FIPS Object Module are subsumed by this latest revision, so there is no reason to use older revisions for any new deployments. However, older revisions remain valid. The source distribution files and corresponding HMAC-SHA-1 digests are listed below:

`openssl-fips-2.0.11.tar.gz`

URL: <http://www.openssl.org/source/old/fips/openssl-fips-2.0.11.tar.gz>

Digest: b9d2a466c66841fcbf65a3cbe21abf81fe140bcf

`openssl-fips-ecp-2.0.11.tar.gz`

URL: <http://www.openssl.org/source/old/fips/openssl-fips-ecp-2.0.11.tar.gz>

Digest: 571662bb0e413bd42f612c695c0b76deb2e9b33e

openssl-fips-2.0.10.tar.gz

URL: <http://www.openssl.org/source/old/fips/openssl-fips-2.0.10.tar.gz>

Digest: af8bda4bb9739e35b4ef00a9bc40d21a6a97a780

openssl-fips-ecp-2.0.10.tar.gz

URL: <http://www.openssl.org/source/old/fips/openssl-fips-ecp-2.0.10.tar.gz>

Digest: 02cc9ddfffb2e917d1cdc9ebc97a9731c40f6394

openssl-fips-2.0.9.tar.gz

URL: <https://www.openssl.org/source/old/fips/openssl-fips-2.0.9.tar.gz>

Digest: 54552e9a3ed8d1561341e8945fcdec55af961322

openssl-fips-ecp-2.0.9.tar.gz

URL: <http://www.openssl.org/source/old/fips/openssl-fips-ecp-2.0.9.tar.gz>

Digest: 91d267688713c920f85bc5e69c8b5d34e1112672

Note that older versions of the FIPS module are migrated from <http://www.openssl.org/source/> to <http://www.openssl.org/source/old/fips/>, so depending on the time at which this document is referenced the URLs above may need to be adjusted accordingly.

Appendix C - Compilers

This appendix lists the specific compilers used to generate the Module for the respective Operational Environments. Note this list does not imply that use of the Module is restricted to only the listed compiler versions, only that the use of other versions has not been confirmed to produce a correct result.

Table 16: Compilers

#	Operational Environment	Compiler
1	TS-Linux 2.4	gcc 4.3.2
2	iOS 8.1 64-bit	clang-600.0.56
3	iOS 8.1 64-bit	clang-600.0.56
4	VxWorks 6.9	gcc 4.3.3
5	iOS 8.1 32-bit	clang-600.0.56
6	iOS 8.1 32-bit	clang-600.0.56
7	Android 5.0	gcc 4.9
8	Android 5.0	gcc 4.9
9	Android 5.0 64-bit	gcc 4.9
10	Android 5.0 64-bit	gcc 4.9
11	VxWorks 6.7	gcc 4.1.2
12	AIX 6.1 32-bit	IBM XL C/C++ for AIX, V13.1
13	AIX 6.1 64-bit	IBM XL C/C++ for AIX, V13.1
14	AIX 7.1 32-bit	IBM XL C/C++ for AIX, V13.1
15	AIX 7.1 64-bit	IBM XL C/C++ for AIX, V13.1
16	DataGravity Discovery Series OS V2.0	gcc 4.7.2
17	DataGravity Discovery Series OS V2.0	gcc 4.7.2
18	AIX 6.1 32-bit	IBM XL C/C++ for AIX, V10.1
19	AIX 6.1 64-bit	IBM XL C/C++ for AIX, V10.1
20	Ubuntu 12.04	gcc 4.6.3
21	Ubuntu 12.04	gcc 4.6.3
22	Linux 3.10	gcc 4.8.1
23	Linux 3.10	gcc 4.8.1
24	Linux 3.10	gcc 4.4.6
25	VMWare ESXi 6.5.0 u1	gcc 4.6.3
26	Red Hat Enterprise Linux 7.3	gcc 4.4.6