



# Aviat Networks Eclipse Cryptographic Module

## FIPS 140-2 Non-Proprietary Security Policy

### Level 2 Validation

Document revision 066, December 2021

Aviat Networks, Inc.  
860 N. McCarthy Blvd., Suite 200  
Milpitas, CA 95035  
408.567.7000  
[www.aviatnetworks.com](http://www.aviatnetworks.com)

Prepared for Aviat Networks by



Rycombe Consulting Limited  
<http://www.rycombe.com>  
+44 1273 476366

© 2021 Aviat Networks, Inc. This document may be reproduced only in its original entirety [without revision]. The information in this document is provided only for educational purposes and for the convenience of the customers of Aviat Networks, Inc. The information contained herein is subject to change without notice, and is provided "as is" without guarantee or warranty as to the accuracy or applicability of the information to any specific situation or circumstance.

## Contents

1	Introduction .....	4
1.1	Identification .....	4
1.2	Purpose.....	4
1.3	References.....	5
1.4	Document Organization .....	5
1.5	Document Terminology.....	6
2	Aviat Networks Eclipse.....	7
2.1	Overview .....	7
2.2	Module Specification.....	7
2.2.1	Hardware and Firmware Components .....	7
2.2.2	Cryptographic Boundary .....	11
2.2.3	Scope of Validation .....	12
2.2.4	Cryptographic Algorithms .....	12
2.2.5	Components Excluded From the Security Requirements of the Standard.....	15
2.3	Physical Ports and Logical Interfaces .....	16
2.4	Roles, Services and Authentication.....	17
2.4.1	Roles.....	17
2.4.2	Services .....	17
2.4.3	Authentication .....	21
2.5	Physical Security.....	22
2.6	Operational Environment.....	29
2.7	Cryptographic Key Management .....	29
2.7.1	Random Number Generators .....	29
2.7.2	Key Generation .....	29
2.7.3	Key Table.....	29
2.7.4	CSP Destruction.....	34
2.7.5	Access to Key Material.....	34
2.8	Self-Tests .....	36
2.8.1	Power-up Self-tests.....	36
2.8.2	Conditional Self-tests .....	38
2.9	Design Assurance .....	38
2.10	Mitigation of Other Attacks.....	39
3	FIPS Mode of Operation.....	40

## Tables

Table 1: Module Hardware .....	4
Table 2: Document Terminology .....	6
Table 3: Required Baseline Components Cards.....	9
Table 4: Hardware Components .....	10
Table 5: Security Level Specification per Individual Areas of FIPS 140-2 .....	12
Table 6: Approved Algorithms .....	14
Table 7: Module Interfaces .....	16
Table 8: LED Status Indicators.....	16
Table 9: Roles .....	17
Table 10: User Services .....	18
Table 11: Crypto-Officer Services .....	19
Table 12: Other Services .....	19
Table 13: Module Cryptographic Keys and CSPs .....	30
Table 14: Module Public Keys .....	30
Table 15: Key Table Part 1 .....	32
Table 16: Key Table Part 2 .....	34
Table 17: Public Key Table Part 1.....	34
Table 18: Public Key Table Part 2.....	34
Table 19: Access to Keys by Services .....	36
Table 20: Power-up Self-Tests .....	37
Table 21: Conditional Self-Tests.....	38

## Figures

Figure 1 Example INUe.....	8
Figure 2 Module Hardware Variant Locations for INUe .....	8
Figure 3 Block Diagram of the Cryptographic Boundary .....	11
Figure 4 Location of Fan Air Filter in INUe.....	20
Figure 5 INUe Enclosure.....	22
Figure 6 Tamper-Evident Seal Locations (Front).....	23
Figure 7 Louver Panel.....	24
Figure 8 Left Hand Louver Panel .....	24
Figure 9 Fitting the Left Hand Louver Panel - 1 .....	25
Figure 10 Fitting the Left Hand Louver Panel – 1 and Position of “Top” Tamper-Evident Seals.....	25
Figure 11 Right Hand Louver Panel.....	26
Figure 12 Fitting the Right Hand Louver Panel - 2 .....	26
Figure 13 Fitting the Right Hand Louver Panel – 2 .....	27
Figure 14 Location of Security Seals on Louver Panel (Left Side) .....	28
Figure 15 Location of Security Seals on Louver Panel (Right Side).....	28

# 1 Introduction

This section identifies the cryptographic module; describes the purpose of this document; provides external references for more information; and explains how the document is organized.

## 1.1 Identification

**Module Name** Aviat Networks Eclipse Cryptographic Module

### Module Hardware

Component	Part number
INUe 2RU Chassis	EXE-002
Fan Card	EXF-101
Node Controller Card	EXN-004
Node Controller Card v3 (NCC v3)	EXN-005
Either FIPS Installation Kit (customer fitted)	179-530153-001
or FIPS Installation Kit (partially factory fitted)	179-530153-002
Replacement Seals	007-600331-001
<b>At least one of:</b>	
RAC 6X	EXR-600-001
RAC 6XE	EXR-600-002
RAC 60	EXR-660-001
RAC 60E	EXR-660-002
RAC 70	EXR-700-001
RAC 70 V2	EXR-700-002
RAC 7X	EXR-770-001
RAC 7X V2	EXR-770-002
<b>All remaining slots filled by one of the components listed in Table 4: Hardware Components</b>	

**Table 1: Module Hardware**

**Firmware Versions** 08.04.91, 08.07.90, 08.09.90, 08.10.97, 08.11.90 with Bootloader version 1.0.36

## 1.2 Purpose

This is the non-proprietary FIPS 140-2 Security Policy for the Aviat Networks Eclipse Cryptographic Module, also referred to as “the module” within this document. This Security Policy details the secure operation of Aviat Networks Eclipse Cryptographic Module as required in Federal Information Processing Standards Publication 140-2 (FIPS 140-2) as published by the National Institute of Standards and Technology (NIST) of the United States Department of Commerce and the Communications Security Establishment (CSE).

### 1.3 References

For more information on Aviat Networks Eclipse please visit:

<http://aviatnetworks.com/products/microwave-switches/eclipse-carrier-ethernet-microwave-platform/>

For more information on NIST and the Cryptographic Module Validation Program (CMVP), please visit

<http://csrc.nist.gov/groups/STM/cmvp/index.html>.

### 1.4 Document Organization

This Security Policy document is one part of the FIPS 140-2 Submission Package. This document outlines the functionality provided by the module and gives high-level details on the means by which the module satisfies FIPS 140-2 requirements. With the exception of this Non-Proprietary Security Policy, the FIPS 140-2 submission documentation may be Aviat Networks proprietary or otherwise controlled and releasable only under appropriate non-disclosure agreements. For access to these documents, please contact Aviat Networks.

The various sections of this document map directly onto the sections of the FIPS 140-2 standard and describe how the module satisfies the requirements of that standard.

## 1.5 Document Terminology

TERM	DESCRIPTION
ACM	Adaptive Coding and Modulation
AES	Advanced Encryption Standard
API	Application Programming Interface
ASIC	Application Specific Integrated Circuit
CAVP	Cryptographic Algorithm Validation Program
CMVP	Cryptographic Module Validation Program
CSP	Critical Security Parameters
CVL	Component Validation List
DAC	Digital Access Card
DRBG	Deterministic Random Bit Generator
DSA	Digital Signature Algorithm
ECCCDH	Elliptic Curve Cryptography Cofactor Diffie-Hellman
ECDSA	Elliptic Curve DSA
eM	Electrical MUX
FIPS	Federal Information Processing Standard
GUI	Graphical User Interface
HMAC	Keyed-Hash Message Authentication Code
INU	Intelligent Node Unit
IRU	Indoor Radio Unit
NCC	Node Control Card
NMS	Network Management System
NPC	Node Protection Card
ODU	Outdoor Unit
OS	Operating System
RAC	Radio Access Card
RSA	An algorithm for public-key cryptography. Named after Rivest, Shamir and Adleman who first publicly described it.
SHA	Secure Hash Algorithm
SNMP	Simple Network Management Protocol
SP	Security Policy
Storage Media	Any media for which Cryptographic Module protection in the form of data encryption is required. Storage Media include internal and external hard drives, memory sticks and floppy disks.
TCP/IP	Transmission Control Protocol/Internet Protocol
TDM	Time-Division Multiplexing
TLS	Transport Layer Security
XPIC	Cross Polarization Interference Cancellation

**Table 2: Document Terminology**

## 2 Aviat Networks Eclipse

This section provides the details of how the module meets the FIPS 140-2 requirements.

### 2.1 Overview

Aviat Networks' Eclipse is an all-in-one next generation dual hybrid and packet microwave radio. Eclipse provides superior networking features to address cost-optimized mobile backhaul, public, and private networking applications, along with high performance RF and Carrier Ethernet capabilities.

Aviat Eclipse delivers a "complete" set of microwave nodal networking capabilities. Eclipse delivers multi-directional integrated microwave switching within a single system, supporting up to 6 RF or up to 45 Ethernet radios in a single rack unit.

Eclipse also supports both native TDM and Ethernet services and provides fully integrated Ethernet switching and IP networking, eliminating the need for external TDM grooming or Ethernet aggregation devices.

Additionally, Eclipse can deliver greater than 2Gbps wireless transport with intelligent and fully integrated bandwidth optimization features like XPIC, ACM, and data compression.

The cryptographic module is housed within the Eclipse Intelligent Node Unit (INUe) chassis.

The Eclipse INUe supports hardware redundancy to maintain data traffic by protecting a link with a backup card that takes over in the event of hardware failure. It is possible to have up to 6 non-protected links or:

- 1 protected/diversity and 4 non-protected links
- 2 protected/diversity and 2 non-protected links
- 3 protected/diversity links

The module provides data security by encrypting the payload traffic on the microwave link between up to three radios. It also provides the Strong Encryption Suite for secure module management and uses AES encryption to secure SNMP v3 management traffic<sup>1</sup>.

### 2.2 Module Specification

#### 2.2.1 Hardware and Firmware Components

The module runs on proprietary hardware. The hardware consists of a number of plug-in cards housed in a proprietary chassis in 2RU format.

The module consists of an Eclipse Node Control Card (NCC), one or more Radio access card (RAC) and a number of other plug-in cards in combination. Only the NCC and RAC cards are involved with

---

<sup>1</sup> The module does not contain an SNMP KDF. SNMP keys are derived externally to the module, and so no claims are made regarding SNMP v3 management traffic.

cryptography. The remaining cards provide physical security via tamper evidence but do not provide any other security relevant functionality.



Figure 1 Example INUe

Slot 1	Slot 2	Slot 3	F
Slot 4	Slot 5	Slot 6	A
Slot 7	Slot 8	Slot 9	N
NCC only			Slot 10
			S

Figure 2 Module Hardware Variant Locations for INUe

- Any of the Slots 1 through 10 may be covered with a blank panel. They shall not be left unpopulated and shall have tamper seals applied per Section 2.5 below.
- Slots 1, 2, 3, 4, 5, and 6 are universal. Any RAC, DAC, NCM or AUX plug-in card.
- Slots 7, 8, and 9 are restricted: any DAC, NCM or AUX, except DAC 155oM/eM where NMS is required.
- Slot 10 is for NPC option only
- NCC and FAN slots are dedicated – the INUe is supplied as standard with a single 2RU FAN, although it accepts two 1RU FANS.
- RAC/RAC or RAC/DAC 155oM/eM protected pairings must be installed in paired slots (Slot 1 and Slot 4, Slot 2 and Slot 5, or Slot 3 and Slot 6).
- For protected DACs or NCMs, the protection partners can be installed in Slots 1 through 9, except for the case of DAC 155oM/eM where NMS access is needed, which is restricted to Slots 1 through 6.

NCC: Node control card

FAN: Fan card (cooling)

RAC: Radio access card (supports the ODU/IRU)

DAC: Digital access card (user interfaces)

AUX: Auxiliary card (auxiliary data and alarm I/O)

NPC: Node protection card (NCC protection)

NCM: Node Convergence Module

Interface traffic options include:

- Ethernet, E1/DS1, E3/DS3, STM1/OC3



- Auxiliary data and alarm I/O

The minimum module configuration requires baseline components, an NCC card, and at least one suitable security relevant RAC card to be installed in order to support the Payload Encryption and Payload Decryption services (see Figure 3).

ITEM	PART NUMBER AND REVISION	FIRMWARE/FPGA VERSION INFORMATION	QUANTITY IN MODULE	CRYPTOGRAPHIC FUNCTIONALITY
<b>BASELINE CONFIGURATION</b>				
<b>INUe 2RU Chassis</b>	EXE-002	N/A	1	No
<b>Node Controller Card</b>	EXN-004	Firmware: 08.04.91 Bootloader: 1.0.36 FPGA_NCCV2_E1_DS1_004.bit FPGA_NCCV2_STM1_006.bit	1	Yes
<b>Node Controller Card v3</b>	EXN-005	Firmware 08.11.90 Bootloader: 1.0.36 FPGA_NCCV3_E1_DS1_010.bit FPGA_NCCV3_STM1_033.bit	1	Yes
<b>Fan Card</b>	EXF-101	N/A	1	No
<b>FIPS Installation Kit</b>	Either: 179-530153-001 (customer fitted) or: 179-530153-002 (partially factory fitted)	N/A	1	No
<b>Replacement Seals</b>	007-600331-001	N/A	1	No
<b>And at least one of the following:</b>				
<b>RAC 6X</b>	EXR-600-001	FPGA_RAC6X_PDH_ACM-14.19.52.bit FPGA_RAC6X_SDH-2.3.1.bit	0-6	Yes
<b>RAC 6XE</b>	EXR-600-002	FPGA_RAC6X_PDH_ACM-14.19.52.bit FPGA_RAC6X_SDH-2.3.1.bit	0-6	Yes
<b>RAC 60</b>	EXR-660-001	FPGA_RAC6X_PDH_ACM-14.19.52.bit FPGA_RAC6X_SDH-2.3.1.bit	0-6	Yes
<b>RAC 60E</b>	EXR-660-002	FPGA_RAC6X_PDH_ACM-14.19.52.bit FPGA_RAC6X_SDH-2.3.1.bit	0-6	Yes
<b>RAC 70</b>	EXR-700-001	FPGA_RAC7X_R2-2.20.6.bit	0-6	Yes
<b>RAC 70 V2</b>	EXR-700-002	FPGA_RAC7X_R2-2.20.6.bit	0-6	Yes
<b>RAC 7X</b>	EXR-770-001	FPGA_RAC7X_R2-2.20.6.bit	0-6	Yes
<b>RAC 7X V2</b>	EXR-770-002	FPGA_RAC7X_R2-2.20.6.bit	0-6	Yes

**Table 3: Required Baseline Components Cards**

If a suitable card is not installed, then the Payload Encryption and Payload Decryption services are not available. All other cards that can be installed in the 2RU chassis are interchangeable (see Figure 4). No slot shall be left unpopulated.

ITEM	PART NUMBER AND REVISION	FIRMWARE/FPGA VERSION INFORMATION	QUANTITY IN MODULE	CRYPTOGRAPHIC FUNCTIONALITY
<b>Fan filter kit, 2RU</b>	131-501768-001	N/A	0-1	No
<b>Aux</b>	EXA-001	FPGA_AUX_132.bit	0-5	No
<b>DAC 4x</b>	EXD-040-001	FPGA_DAC_4E1_DS1-15.1.4.bit FPGA_DAC_4E1_WAYSIDE-15.1.4.bit	0-5	No
<b>DAC 155o</b>	EXD-152-001	FPGA_DAC_155_MUXV2-2.1.3.bit	0-5	No
<b>DAC 155oM (long)</b>	EXD-153-001	FPGA_DAC_155_MUX_001.bit	0-5	No
<b>DAC 155oM (short)</b>	EXD-156-001	FPGA_DAC_155_MUXV2-2.1.3.bit	0-5	No
<b>DAC 155eM</b>	EXD-158-001	FPGA_DAC_155_MUXV2-2.1.3.bit	0-5	No
<b>DAC 16x</b>	EXD-160-001	FPGA_DAC_16E1_DS1-15.1.4.bit	0-5	No
<b>DAC 16xV2</b>	EXD-161-001	FPGA_DAC16V2_E1_DS1-3.1.4.bit	0-5	No
<b>DAC 16xV3</b>	EXD-161-002	FPGA_DAC16V2_E1_DS1-3.1.4.bit	0-5	No
<b>DAC ES</b>	EXD-171-001	FPGA_DAC_ES_018.bit	0-5	No
<b>DAC GE v2</b>	EXD-180-002	N/A	0-5	No
<b>DAC LL</b>	EXD-180-005	N/A	0-5	No
<b>DAC GE v2 no SFP</b>	EXD-180-102	N/A	0-5	No
<b>DAC GE3</b>	EXD-181-001	FPGA_DAC_E3_MUX_132.bit	0-5	No
<b>DAC GE3</b>	EXD-181-002	FPGA_DAC_E3_DS3_NOMUX_002.bit	0-5	No
<b>DAC 2x155o</b>	EXD-252-001	FPGA_DAC_2STM1_020.bit	0-5	No
<b>DAC 3xE3M</b>	EXD-331-001	N/A	0-5	No
<b>NCM</b>	EXD-400-002	FPGA_NCM-1.1.112.bit FPGA_NCM_CES-1.1.417.bit FPGA_NCM_CES1-1.1.443.bit FPGA_NCM_HSF-1.0.133.bit FPGA_NCM_HSF_FIX-1.1.152.bit	0-5	No
<b>24V card</b>	EXP-024	N/A	0-1	No
<b>RAC LL</b>	EXR-910-001	FPGA_RACLL_IFC-3.1.8.bit	0-6	No
<b>RAC 30v3</b>	EXR-999-003	FPGA_RAC30_E3_DS3_002.bit	0-6	No
<b>NPC</b>	EXS-001	N/A	0-1	No
<b>NPC, high output</b>	EXS-002	N/A	0-1	No
<b>Blank panel</b>	EXX-001	N/A	0-10	No

Table 4: Hardware Components

### 2.2.2 Cryptographic Boundary

The cryptographic boundary of the module is the hardware chassis. The module is a hardware module with firmware running on the NCC card within the chassis.

The processor of this platform executes all firmware. All firmware components of the module are persistently stored within the device and, while executing, are stored in the device local RAM.

Optionally, an ASIC on the RAC card provides the necessary functionality to support the Payload Encryption and Payload Decryption services.

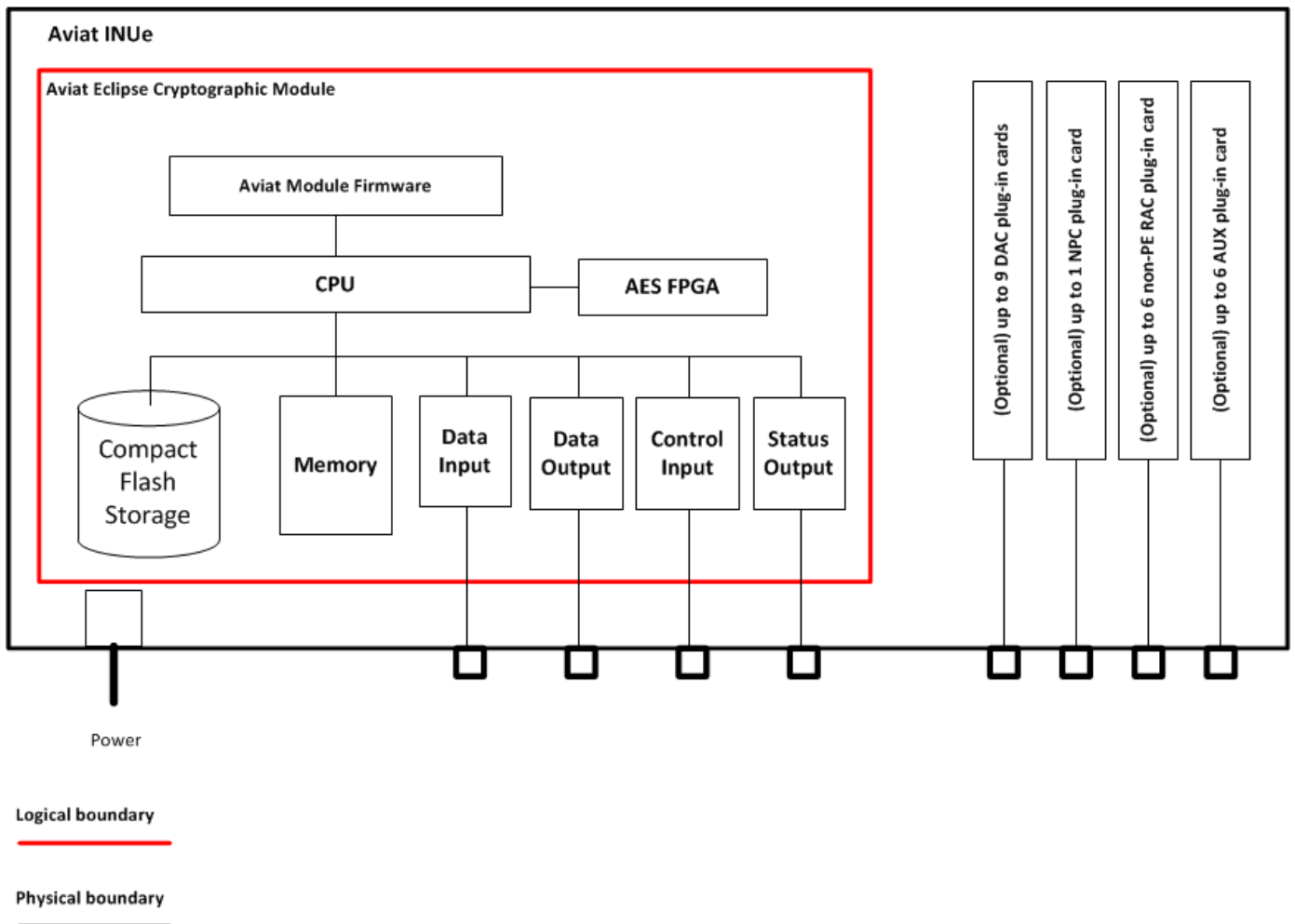

Figure 3 Block Diagram of the Cryptographic Boundary

### 2.2.3 Scope of Validation

The cryptographic module meets the overall requirements applicable to Level 2 security of FIPS 140-2, with Cryptographic Module Specification at Level 3 and Design Assurance at Level 3.

SECURITY REQUIREMENTS SECTION	LEVEL
Cryptographic Module Specification	3
Module Ports and Interfaces	2
Roles, Services and Authentication	2
Finite State Model	2
Physical Security	2
Operational Environment	N/A
Cryptographic Key Management	2
EMI/EMC	2
Self-Tests	2
Design Assurance	3
Mitigation of Other Attacks	N/A

Table 5: Security Level Specification per Individual Areas of FIPS 140-2

### 2.2.4 Cryptographic Algorithms

#### 2.2.4.1 Approved algorithms

The following table provides details of the Approved algorithms that are included within the module:

ALGORITHM TYPE	ALGORITHM	CAVP CERTIFICATE	USE
<b>Symmetric key</b>	AES-128-ECB, AES-192-ECB, AES-256-ECB, AES-128-CCM, AES-192-CCM and AES-256-CCM (Encryption only)	#C5	Payload Encryption
	AES-128-CBC, AES-256-CBC and AES-256-CFB128.	#C1	Strong Security Suite and Encryption of SNMPv3 sessions

ALGORITHM TYPE	ALGORITHM	CAVP CERTIFICATE	USE
	(ECB was tested but is not used)		
<b>SP 800-135 component</b>	Section 4.2, TLS	#C1	Within TLS (v1.2)  Cipher suites supported: TLS_ECDH_ECDSA_WITH_AES_128_CBC_SHA256, TLS_ECDH_ECDSA_WITH_AES_256_CBC_SHA, TLS_ECDH_ECDSA_WITH_AES_128_CBC_SHA
<b>CVL</b>	ECCCDH	#C1	TLS cipher suites. ECCCDH SP 800-56A for NIST defined P-224 and P-256 Curves
<b>Deterministic Random Bit Generator</b>	SP 800-90A Hash-based DRBG	#C1	Key generation. Hash used is SHA-512.
<b>Cryptographic Key Generation</b>	CKG	VA	SP 800-133 compliant key generation. Cryptographic key generation compliant with 6.1, 6.2, 7.1, 7.2, and 7.4. Keys result from unmodified output from the DRBG.
<b>Asymmetric key</b>	ECDSA	#C1	TLS cipher suites. NIST defined P-224 and P-256 curves. Cipher suite uses signature generation and verification.
<b>Key Transport Scheme</b>	KTS	#C1 (AES), #C1 (HMAC)	TLS used to transport the Payload Encryption Key Meets the SP800-38F §3.1 requirements for symmetric key wrapping. Key establishment methodology provides between 128 and 256 bits of encryption strength.
<b>Authentication</b>	HMAC-SHA-1 HMAC-SHA-256 (HMAC-SHA-384 was tested but is not used)	#C1	Within TLS and for SNMPv3
<b>Asymmetric key</b>	RSA	#C1	Firmware load test, module integrity test. Image has been hashed using SHA-256 and then signed with a 2048-bit RSA key. RSA signature verification is used in the self-test procedure.
	RSA	#2239	Bootloader integrity test. 2048-bit RSA with SHA-256.
<b>Hashing</b>	SHA-1	#C1	Used by SNMPv3 to obfuscate authentication messages.
	SHA-256 SHA-512		Firmware load test, Module integrity test, Hash DRBG, TLS cipher suite.

ALGORITHM TYPE	ALGORITHM	CAVP CERTIFICATE	USE
	(SHA-384 was tested but is not used)		
	SHA-256	#3397	Bootloader integrity test.

Table 6: Approved Algorithms

For each Approved Key Derivation Function the module supports or uses a corresponding protocol. Any such related protocol can be used in the Approved mode of operation, but has not been reviewed or tested by the CAVP and CMVP as testing such protocols is not within the scope of CMVP or CAVP activities.

#### 2.2.4.2 Non-Approved algorithms allowed in Approved mode

- Elliptic Curve Diffie-Hellman, not compliant (untested) to SP800-56A but allowed by IG D.8 (key agreement; key establishment methodology provides between 112 bits and 128 bits of encryption strength)
- MD5
- NDRNG for seeding material to the FIPS Approved SP800-90A DRBG. The NDRNG provides at least 256 bits of entropy.

Elliptic Curve Diffie-Hellman is used for Payload Encryption key exchange. The module uses MD5 to hash firmware components to check integrity. This check is run in addition to the RSA integrity test and predates the FIPS Firmware integrity test. It is not security relevant. MD5 is also employed in RADIUS.

#### 2.2.4.3 Non-Approved algorithms

The following algorithms are also included within the module and available in the Approved mode, but are only used by RADIUS for tasks related to authentication.

- MD5-CFB for encrypted password output to RADIUS server (RFC 2865 §5.2)
- MD5-MAC for authentication of RADIUS server (RFC 2865 §3, "Response Authenticator")

The following algorithms are also included within the module but *are only available within the module services in a non-FIPS mode* of operation:

- Triple-DES
- DES
- Diffie-Hellman (key agreement; key establishment methodology provides 112 bits of encryption strength)

DES is used for securing the management interface (Portal) in a non-Approved mode of operation. Diffie-Hellman is used for Payload Encryption key exchange.

### **2.2.5 Components Excluded From the Security Requirements of the Standard**

The following observable, non-security relevant components are excluded from FIPS 140-2 requirements:

- The components of all cards listed in Figure 4 except the faceplates. Since tamper-evident seals are applied and necessary for physical security protection, the faceplates are security relevant and cannot be excluded. All other card components are excluded from FIPS requirements because they are non-security relevant.
- Components along both left and right sides of the RAC cards with the exception of U42 on cards RAC 6X, RAC 6XE, RAC 60, RAC 60E, RAC 70, RAC 70 V2, RAC 7X and RAC 7X V2.

## 2.3 Physical Ports and Logical Interfaces

The module is classified as a multi-chip standalone module for FIPS 140-2 purposes. The module's physical boundary is that of the INUe chassis.

The module provides its logical interfaces via the physical interfaces provided in the chassis. These logical interfaces expose the services (described in section 2.4.2) provided by the module.

The logical interfaces provided by the module are mapped onto the FIPS 140-2 logical interfaces: data input, data output, control input, and status output as follows:

FIPS 140-2 LOGICAL INTERFACE	MODULE MAPPING
Data Input	<p>INUe Front panel sockets. The NCC component has four NMS connectors, providing Ethernet access for Portal or ProVision (<a href="http://www.aviatnetworks.com/products/network-managementos/provision/">http://www.aviatnetworks.com/products/network-managementos/provision/</a>). Pin assignments represent industry-standard LAN cable assembly for a 10/100Base-T, RJ-45 connector. It also has a V.24 connector providing serial data access for Portal. (See Figure 5 for an image of the physical ports.)</p> <p>Data enter and leave RAC adapters via a single RJ-45 Ethernet socket. There is an RF socket to connect the RAC to a radio transceiver so that the data can be sent and received on a microwave link.</p>
Data Output	INUe Front panel sockets
Control Input	INUe Front panel sockets
Status Output	INUe Front panel sockets and LEDs
Power Interface	NCC power interface and optional NPC. Power input limits are -40.5 to -60 V DC. The power connector is a D-Sub M/F 2W2. The positive DC return pin is connected to chassis ground.

Table 7: Module Interfaces

LED status indicators:

EVENT	NCC STATUS LED	NCC TEST LED	RAC STATUS LED
<b>FIPS Power-up self-tests in progress</b>	Flashing orange	Flashing orange	Solid red
<b>Power-up self-test failure</b>	Solid red	Off	Solid red
<b>Self-tests pass/FIPS (Approved) mode enabled</b>	Solid green	Solid green	Solid green

Table 8: LED Status Indicators

When the three indicated LEDs are green, the module is in the Approved mode of operation. The use of the Approved mode locks out the use of non-Approved algorithms.



## 2.4 Roles, Services and Authentication

### 2.4.1 Roles

The Cryptographic Module implements both a Crypto-Officer role and a User role. Roles are assumed explicitly using the authentication mechanisms described below. Section 2.4.2 summarizes the services available to each role.

ROLE	DESCRIPTION
Crypto-Officer	Mapping to a combination of the Eclipse's "Crypto", "Engineer" and "Admin" users. Crypto-Officer is able to configure security settings and payload encryption and manage user accounts.
User	Mapping on to the Eclipse "Read-only" user. A User is able to view the configuration for a specific link.
Maintenance	This role supports the capability for users to add or remove plug-in cards to the module to provide extra bandwidth or different data formats. It also allows for the insertion and removal of an optional fan air filter. Crypto-Officer support is required to perform Maintenance services.

Table 9: Roles

Multiple concurrent operators are allowed. Up to five operators may be logged on to the module at any one time. It is possible for an operator in the User role and one in the Crypto-Officer role to be logged on concurrently.

### 2.4.2 Services

#### 2.4.2.1 User Services

The following services may only be performed by an operator with "User" access permissions who has been successfully authenticated to the module.

SERVICE	SERVICE INPUT	SERVICE OUTPUT	DESCRIPTION
RADIUS	Authentication request, username and password	Success/fail	User authentication using RADIUS. Successful authentication permits the identified User access to Craft Tool User Services.
Craft Tool Authentication	Authentication request, username and password	Success/fail	User authenticated locally by module. Successful authentication permits the identified User access to Craft Tool User Services. These allow a User to configure the characteristics of a specific microwave radio links, including enabling or disabling that link.
View Configuration	View Configuration	Event log entry	Provides a user with configuration

SERVICE	SERVICE INPUT	SERVICE OUTPUT	DESCRIPTION
	Request		information as an event log

Table 10: User Services

#### 2.4.2.2 Crypto-Officer Services

The following services may only be performed by an operator with “Crypto-Officer” access permissions who has been successfully authenticated to the module.

SERVICE	SERVICE INPUT	SERVICE OUTPUT	DESCRIPTION
Enable Payload Encryption	Request to switch on payload encryption for a specific link	Success/Fail	A Crypto-Officer may configure a secure data link to enable payload encryption.
Disable Payload Encryption	Request to switch off payload encryption for a specific link	Success/Fail	Although only a Crypto-Officer may configure a secure data link, a User may enable and disable encryption on a specific microwave radio link.
Craft Tool Authentication	Authentication request, username and password	Success/fail	Crypto-Officer authenticated locally by module. Successful authentication permits the identified Crypto-Officer access to Craft Tool Services.
Firmware Upgrade	Update request and firmware image	Success/fail	Successfully updating the firmware loads the new image into module and reboots the module to allow the new firmware to become operational. If the firmware update fails, then the new image is not loaded and the module rolls back to the original firmware and this remains operational.
Zeroize	Zeroize request	Success/fail	Zeroizes all plaintext secret and private cryptographic keys and CSPs within the module, specifically those listed in section 2.7.3.
Key Management (Payload Encryption)	Link ID. Service accessed via Craft tool GUI	Event log entry indicates success/failure	Generates a new key for the selected link.
Key Management (Secure Management)	Enable strong security via GUI	Event log entry indicates success/failure	Enabling strong security is a requirement of the FIPS mode of operation. Once enabled, the key management is automatic. Keys are established as required and used to secure the appropriate services.
Module	Craft tool GUI	Confirmation of	The Craft tool is used to configure the

SERVICE	SERVICE INPUT	SERVICE OUTPUT	DESCRIPTION
Configuration		parameters and actions	“strong security suite” within the module.
SNMP v3	Secure SNMP session request	Secure SNMP session	SNMPv3 keys are manually entered. There is no internal key derivation and so for the purposes of validation, no claims are made for the security of the SNMPv3 service.
RADIUS	Authentication request, username and password	Success/fail	Crypto-Officer authentication using RADIUS. Successful authentication permits the identified Crypto-Officer access to Craft Tool Services.
View Status Request	View Status Request	Event log entry	Provides a Crypto-Officer with status information as an event log.

Table 11: Crypto-Officer Services

#### 2.4.2.3 Unauthenticated Services

SERVICE	SERVICE INPUT	SERVICE OUTPUT	DESCRIPTION
Payload Encryption	Plaintext payload data	Encrypted payload data	Once a microwave link is configured and keys are established, any data sent on the link will be encrypted
Payload Decryption	Encrypted payload data	Plaintext payload data	Decrypts payload data received on a secure microwave link.
Perform Self-Tests	Power-up module	Self-test status	Self-tests are performed automatically at startup. If the self-tests fail, the module enters an error state. If they succeed, the module becomes operational.
View Status indicators	N/A	LED indicators	LED indicators provide information about the state of the payload encryption service and the self-test results.

Table 12: Other Services

#### 2.4.2.4 Maintenance

Maintenance consists of inserting, removing or replacing plug-in cards and the fan air filter. The Crypto-Officer must perform the zeroize service and then power down the module. The module must remain powered down during maintenance and then the Crypto-Officer must power up the module and perform the zeroize service to complete the maintenance.

##### Plug-in Cards

To remove a plug-in card or blank, remove its tamper-evident seals, loosen its front-panel fastening screws and pull it towards you. Inserting a card may require the removal of a blank to access the card slot. To insert a plug-in card, push it into the appropriate slot. Ensure its backplane connector is correctly engaged before applying sufficient pressure to bring the plug-in panel flush with the front panel. Secure the card using its fastening screws.

##### Fan Air Filter

For the INUe, a fan air filter kit is supplied, comprising a filter frame, filter element, and fastening screw. It is installed in the INUe to the right side of the FAN module, as illustrated below.

Remove the FAN module and slide the air filter into the chassis so that it locates to the right side of the FAN module backplane connector, and up against the chassis side. FAN module removal and replacement does not affect traffic.

Installation instructions are included with the fan filter kit.

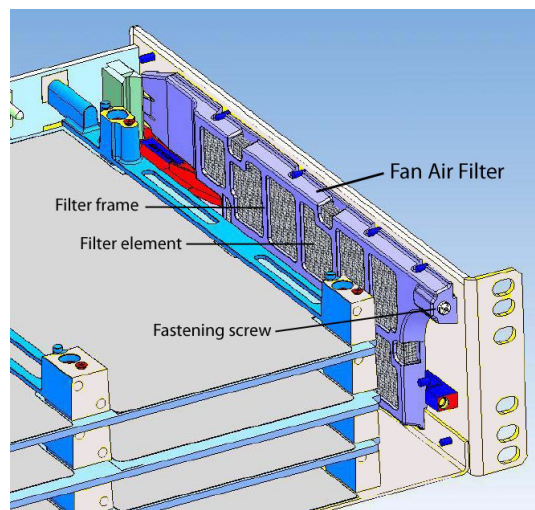

Figure 4 Location of Fan Air Filter in INUe

### Renewing Physical Security Following a Maintenance Task

The physical security measures must be checked and renewed as appropriate following any module maintenance. When replacing a tamper-evident seal, any residue from a previous seal must be removed before a new seal is applied.

#### 2.4.3 Authentication

The module uses role-based and identity-based operator authentication. RADIUS may be used for user authentication and RADIUS is authenticated to the module using a shared secret. The RADIUS authentication is role-based. All other authentication is identity based.

User and Crypto-Officers are authenticated by presenting a username and password to the module for authentication. This is either done locally by the module using its own list of local users and their credentials or remotely using a RADIUS server and a centrally held database of users and credentials. If the user identity and password match stored values then authentication is successful.

Locally defined passwords:

The passwords for the User and Cryptographic Officer roles, authenticating via the Portal GUI, are alphanumeric strings of between 8 and 32 alphanumeric characters comprised of at least one letter and one number.

The minimum number of possible passwords is, therefore,  $94^6 \cdot 10^{52}$  or  $3.59 \times 10^{14}$ , which exceeds the minimum requirement of 1 in 1,000,000 for unsuccessful authentication probability.

With the minimum 8-character password of the required composition, that still gives a random chance of guessing the correct password in a single attempt of 1 in  $94^6 \cdot 10^{52}$ , or 1 in  $3.59 \times 10^{14}$ . Real-world passwords will normally be more complex than this. The module locks out user logon attempts for one minute after three consecutive logon failures. Assuming the weakest password and the ability of an attacker to make three logon attempts in a minute, this still gives the random chance of successfully guessing correctly a password given multiple attempts in a minute at slightly less than three times the single attempt chance, or very roughly 1 in  $1 \times 10^{13}$ , which is significantly more secure than the 1 in 100,000 required.

RADIUS passwords:

The passwords for the User and Cryptographic Officer roles, authenticating via RADIUS, are alphanumeric strings consisting of a minimum of 5 characters. The minimum number of possible passwords is therefore  $94^5$ , which exceeds the minimum requirement of 1 in 1,000,000 for unsuccessful authentication probability.

The module only allows three consecutive unsuccessful authentication attempts in any one minute period. Therefore, the probability of successfully authenticating to the module within one minute through random attempts is  $3/94^5$  which is less than  $1/100,000$ .

## 2.5 Physical Security

The module is entirely encased by a thick steel chassis. The back of the chassis is completely closed off and internally has a backplane into which plug-in cards may be inserted. The front of the chassis, where plug-in cards are inserted, must be sealed in a commissioned module. The sides of the chassis have vent holes to allow air to flow across components within the module to provide cooling and prevent overheating.

The INUe enclosure (Figure 5) has an NCC card and ten expansion slots, each of which must either contain a plug-in card or be covered by a blanking plate.



Figure 5 INUe Enclosure

Physical security kits 179-530153-001 and 179-530153-002 are identical in content. However, for each installation only one kit is required. Kit 179-530153-001 is used where the operator installs the louvers and kit 179-530153-002 is used when the louvers are factory fitted.

All parts of Kit 179-530153-001 are installed by the operator.

Kit 179-530153-002 is partially factory fitted. The louvers shown in Figure 7 and its tamper-evident seals are installed in the factory. The INUe is then installed in its equipment rack prior to shipment. The operator applies all of the front panel tamper evident seals.

The module is supplied with a set of twenty-three (23) tamper-evident seals consisting of two (2) different types of seals. There are fifteen (15) white narrow seals that are used on the top front and on the front panel and must be fitted correctly to satisfy the physical security requirements for the module (see Figure 6 and Figure 10). In addition, there are eight (8) wider holographic seals used for the side louver panels (see Figure 14 and Figure 15). Once a module is commissioned, the seals must be applied by the operator to the NCC, plug-in cards and blanking plates, such that for each item that borders that chassis, there is a seal joining the item to the chassis. For each item that does not border the chassis, there is a seal linking it to its neighbor.

To install the tamper-evident seals on front panel (physical security kits 179-530153-001 and 179-530153-002):

- Verify that the front panel is contiguous

- For slots that do not contain plug-in cards, fit a blank panel (HW P/N EXX-001 per Figure 1)
- Remove excessive grease, dirt, or oil from the cover if appropriate by using alcohol-based cleaning pads before applying the tamper evident seals. The chassis temperature should be above 10° C (50° F).
- Affix (12) narrower tamper-evident seals as indicated in Figure 6 below such that it is not possible to remove either a single card or a group of cards without also removing a seal and leaving tamper evidence.
- Install the INUe shelf into the rack and apply security seals over front of the cards in the chassis as shown. Use caution to avoid touching the adhesive with fingerprints to avoid damaging the seals. Allow the seal adhesive at least sixty (60) minutes to cure.
- The tamper-evident seals should be replaced whenever components are added or removed from the module. Replacement seals can be ordered from Aviat Networks, part number 007-600331-001
- Tamper-evident seals should be inspected for integrity at least once every six (6) months

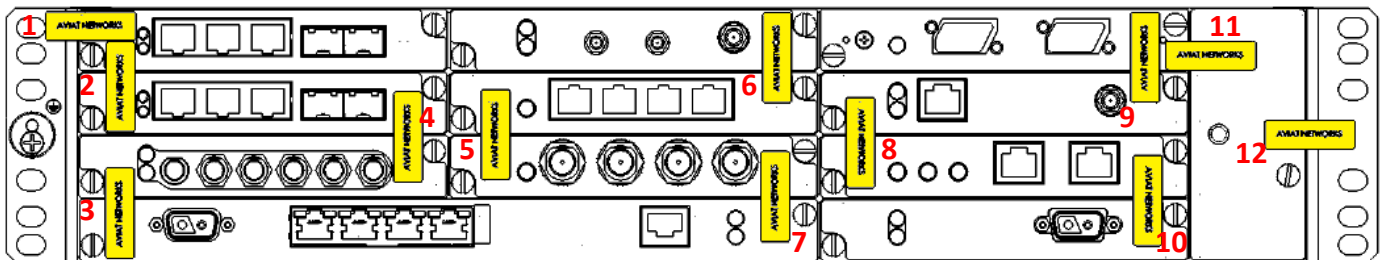
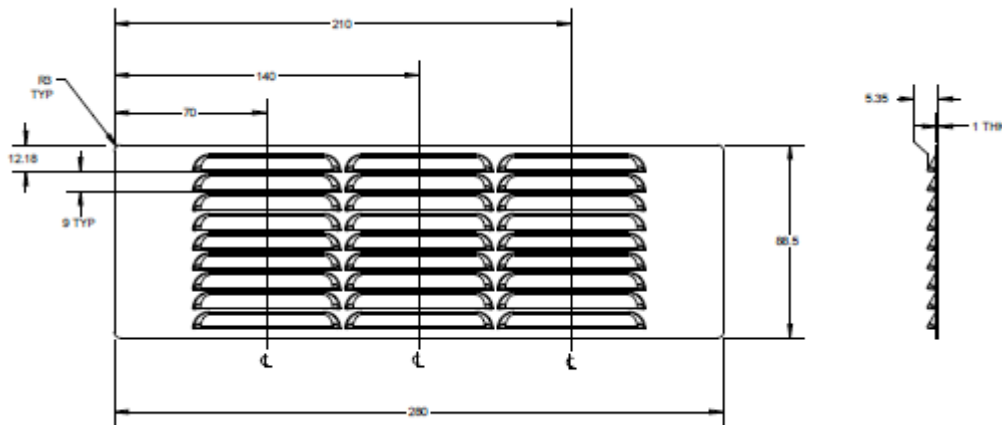

Figure 6 Tamper-Evident Seal Locations (Front)

Opacity: The module enclosure has vent holes at the sides. The vent holes are covered by louver panels that provide no line of sight view of any internal components that are affixed with double sided PSA foam tape. Once secured, four (4) tamper-evident seals are fitted to each louver panel (see Figure 14 and Figure 15).



**Figure 7 Louver Panel**

The tamper-evident seals and louver panels/filters shall be installed for the module to operate in a FIPS Approved mode of operation.

The Crypto-Officer is responsible for the application and maintenance per the physical security policy:

To fit and affix the louver panels (physical security kit 179-530153-001):

All surfaces must be clean and dry prior to installation. Wipe the side of the INUe surfaces with isopropyl alcohol and let dry. Place the INUe shelf on flat surface and install the louver panels as shown below.

***Left Hand Side (as viewed from the front)***

- Locate the louver panel and remove the paper backing from the double sided pressure sensitive adhesive (PSA) foam tape.

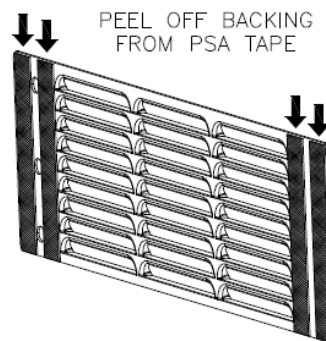

**Figure 8 Left Hand Louver Panel**

- Align the front edge of the louver panel with the edge of the radius near the front mounting ear.
- Align the bottom edge of the louver panel with the bottom edge of the INUe shelf.



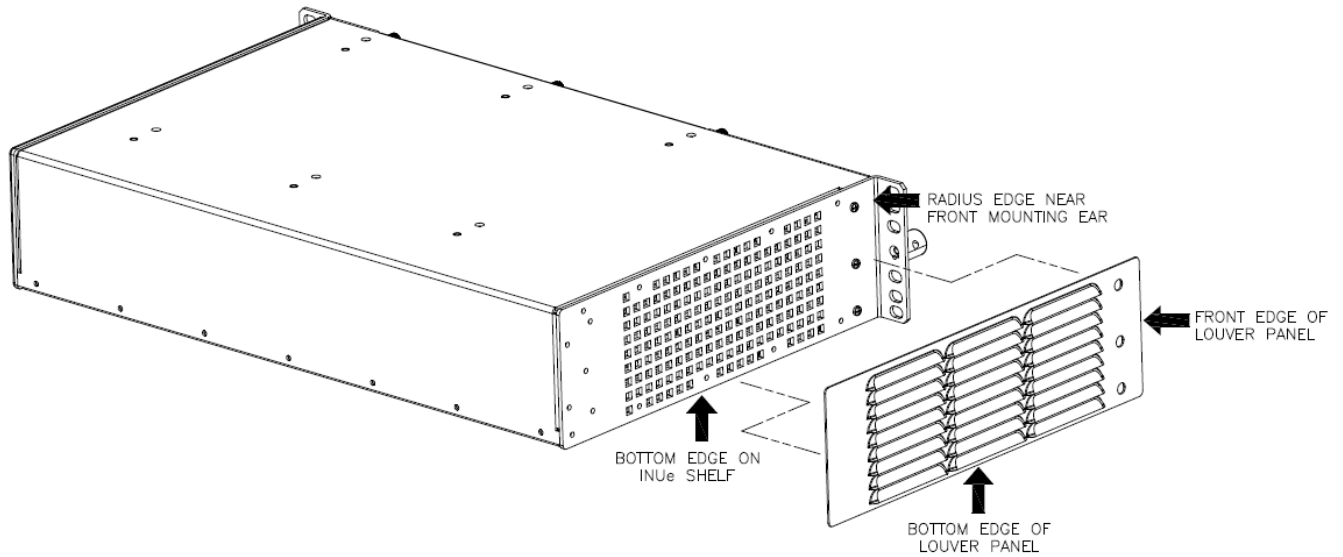

**Figure 9 Fitting the Left Hand Louver Panel - 1**

- Apply strong pressure to the side of the louver panel to bond the PSA to the INUe shelf.

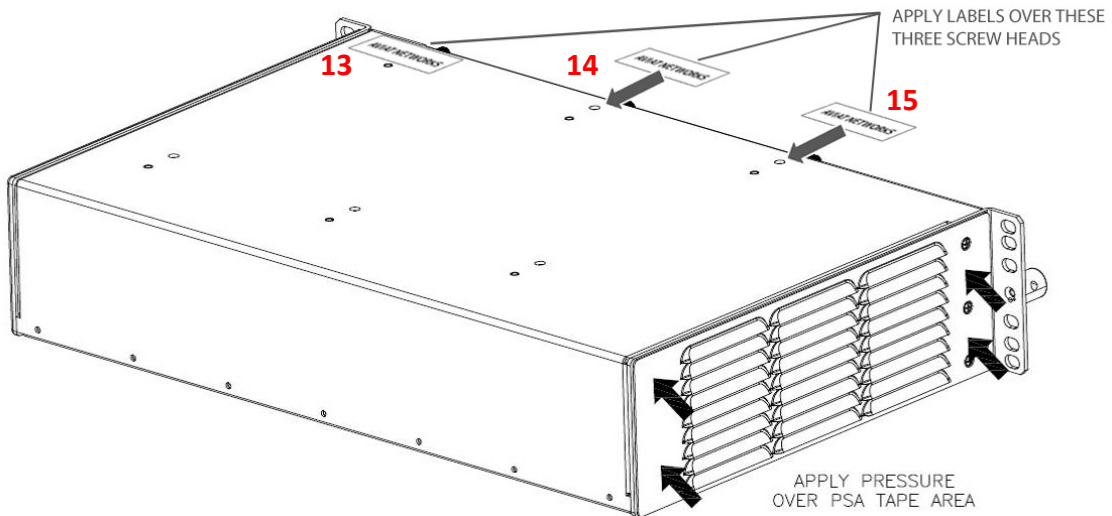

**Figure 10 Fitting the Left Hand Louver Panel – 1 and Position of “Top” Tamper-Evident Seals**

- Let the louver panel PSA cure for at least five (5) minutes before proceeding to install the right hand side.

***Right Hand Side (as viewed from the front)***

- Locate the louver panel and remove the paper backing from the double sided PSA foam tape.

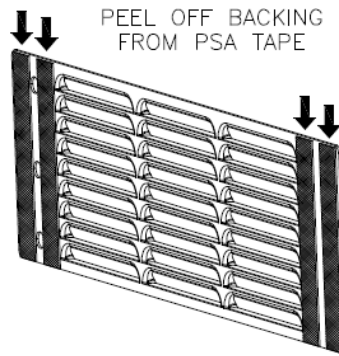

Figure 11 Right Hand Louver Panel

- Align the front edge of the louver panel with the edge of the radius near the front mounting ear.
- Align the bottom edge of the louver panel with the bottom edge of the INUe shelf.

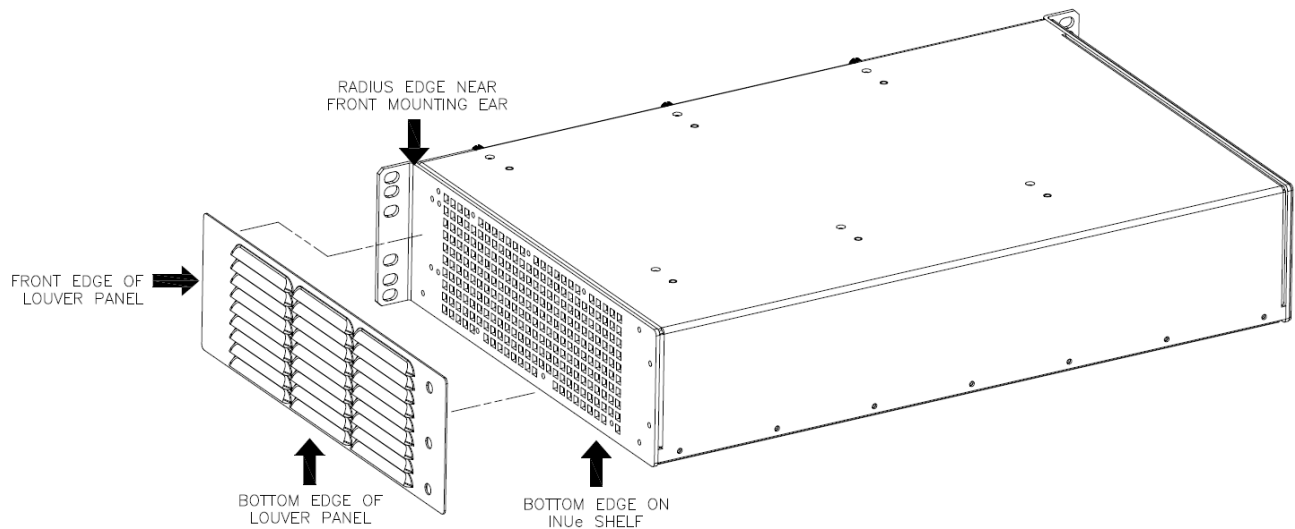
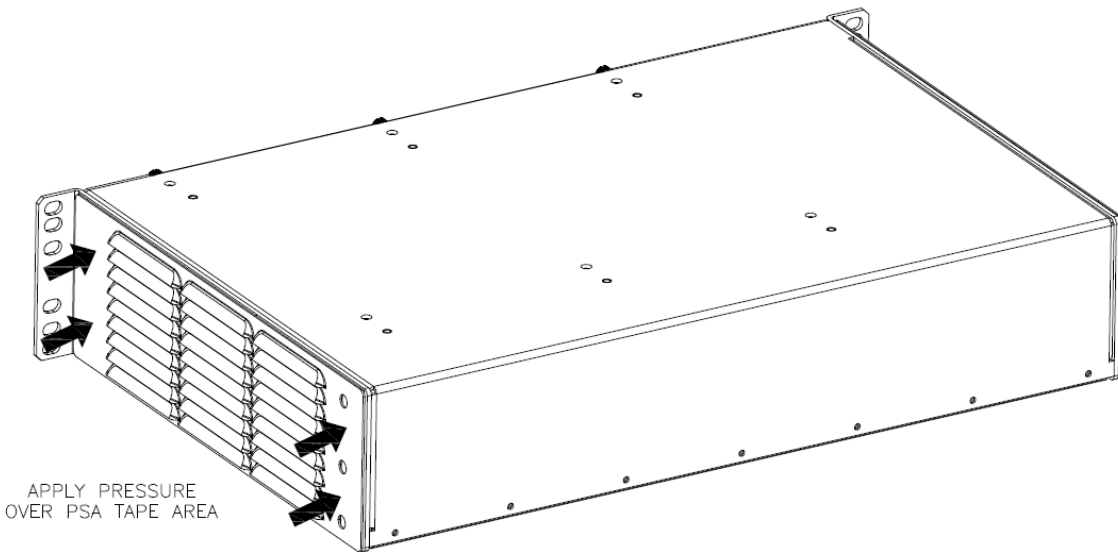

Figure 12 Fitting the Right Hand Louver Panel - 2

- Apply strong pressure to the side of the louver panel to bond PSA to the INUe shelf.



**Figure 13 Fitting the Right Hand Louver Panel – 2**

- Let the louver panel PSA cure for at least five (5) minutes then proceed to installing the security seals to both sides.

Apply security SEALS over louver panels:

***Left hand side (as viewed from the front)***

- Apply the wider security seal over louver panel and across INUe chassis. Use caution to avoid touching the adhesive with fingerprints to avoid damaging the seals. Allow the seal adhesive at least sixty (60) minutes to cure.



**Figure 14 Location of Security Seals on Louver Panel (Left Side)**

***Right hand side (as viewed from the front)***

- Apply the wider security seal over louver panel and across INUe chassis. Use caution to avoid touching the adhesive with fingerprints to avoid damaging the seals. Allow the seal adhesive at least sixty (60) minutes to cure.



**Figure 15 Location of Security Seals on Louver Panel (Right Side)**

Immediately before the INUe is installed into its rack/cabinet, apply the narrower tamper evident seals as shown in Figure 10 with a seal over each of the three (3) top-front screw heads, and apply the four (4) wider seals per side as indicated in Figure 14 and Figure 15.

- Clean the areas where the seals are to be applied as appropriate using alcohol-based cleaning pads or a rag moistened with isopropyl alcohol, and let dry.
- When peeling and placing the seals avoid finger contact with the seal backing/adhesive to prevent damage to the seal. The use of tweezers applied on the edge of the seal is recommended.
- Ensure the seals are not damaged when installing the INUe into its rack/cabinet.

Louver panels (physical security kit 179-530153-002):

- Louvers and all associated tamper evident seals (detailed in the section above for kit 179-530153-001) will already be installed to the INUe.
- The operator must fully check the condition of the louvers and tamper evident seals applied to the louvers and replace any physical security items that are not fully intact.

## 2.6 Operational Environment

The module operational environment is derived from a version of embedded Linux. This has been adapted such that there is no general purpose operating system functionality available to an operator.

The only firmware that can be loaded is the module firmware. The module firmware can be updated using the “Firmware Upgrade” service. This requires the verification of a digital signature.

The Operating Environment of the module is a *limited operational environment* and so the Section 6 Operational Environment requirements are not applicable.

## 2.7 Cryptographic Key Management

### 2.7.1 Random Number Generators

The module contains an Approved SP 800-90A Hash-based DRBG.

### 2.7.2 Key Generation

Keys generated internally are generated by the SP 800-90A DRBG seeded by system entropy. The module uses the Hash-based DRBG to generate symmetric AES keys and Asymmetric ECDSA key pairs.

### 2.7.3 Key Table

The following tables list all of the keys and CSPs within the module, describe their purpose, and describe how each key is generated, entered and output, stored and destroyed.

KEY	PURPOSE
<b>TLS Private Key</b>	ECDSA/ECDH P-224 or P-256 key used to establish TLS tunnel for HTTPS and WMTS ports for managing remote radio.
<b>TLS Tunnel Keys</b>	Encrypt TLS session for the Craft tool and web server. AES-128 or AES-256, depending on cipher suite.
<b>TLS HMAC Keys</b>	Message authentication within TLS. HMAC/SHA-1 or HMAC/SHA-256, depending on cipher suite.
<b>RADIUS Shared Secret</b>	Used to verify RADIUS messages.
<b>SNMPv3 Privacy Key</b>	Used for encrypting SNMPv3 packets. AES-128.
<b>SNMPv3 Authentication Key</b>	Used for authenticating SNMPv3 packets. HMAC/SHA-1.
<b>Payload Encryption Private</b>	ECDSA/ECDH P-224 or P-256 key used to establish the

<b>Key</b>	Payload Encryption DTLS tunnel key.
<b>Payload Encryption DTLS Tunnel Keys</b>	Used to encrypt the tunnel established using DTLS. AES-256.
<b>Payload Encryption DTLS HMAC Keys</b>	Used to authenticate the tunnel established using DTLS. HMAC/SHA-1.
<b>Payload Encryption Key</b>	Used to encrypt/decrypt payload. Only AES-128, 192 or 256 bits are used for payload encryption.
<b>Hash DRBG C and V</b>	These are variables used internally by the Hash DRBG that are required by Implementation Guidance 14.5 to be listed in the Cryptographic Module Security Policy document. They represent the internal state of the DRBG.
<b>Hash DRBG Seed</b>	Seed for the Hash DRBG.
<b>User Password</b>	Used to authenticate User to Craft Tool.
<b>Crypto-Officer Password</b>	Used to authenticate Crypto-Officer to Craft Tool.

Table 13: Module Cryptographic Keys and CSPs

KEY	PURPOSE
<b>TLS Certificate</b>	<p>Self-generated and self-signed certificate used to establish TLS tunnel for HTTPS and WMTS ports for managing remote radio. Certificate's public key is ECDSA/ECDH.</p> <p>Can use any of the following cipher suites to establish tunnel:</p> <p>TLS_ECDH_ECDSA_WITH_AES_128_CBC_SHA256,            TLS_ECDH_ECDSA_WITH_AES_256_CBC_SHA,            TLS_ECDH_ECDSA_WITH_AES_128_CBC_SHA</p>
<b>Payload Encryption Certificate</b>	<p>Self-generated and self-signed certificate used to generate the Payload Encryption Tunnel Key and Payload Encryption HMAC Key. Certificate's public key is ECDSA/ECDH.</p> <p>The mechanism for exchanging the Payload Encryption key is to create a TLS tunnel first and then transmit the generated AES key to the remote end. For this we are using a different self-signed TLS certificate and secret key from the HTTPS and WMTS TLS tunnel. The TLS_ECDH_ECDSA_WITH_AES_256_CBC_SHA cipher suite is used.</p>
<b>Integrity key</b>	A fixed and hard coded key used in the firmware load conditional self-test

Table 14: Module Public Keys



KEY	KEY TYPE AND STRENGTH	GENERATION/ESTABLISHMENT	STORAGE LOCATION
<b>TLS Private key</b>	ECDSA/ECDH P-224 or P-256 curve	Generated by module	Flash memory
<b>TLS tunnel keys</b>	112, 128 or 256 bit depending on TLS cipher suite used	Key is established using TLS	RAM
<b>TLS HMAC keys</b>	160 bits	Established using TLS	RAM
<b>RADIUS shared secret</b>	5-32 characters	Entered by Crypto-Officer	RAM, Flash memory
<b>SNMPv3 privacy key</b>	128 bits	Entered by Crypto-Officer	RAM, Flash memory
<b>SNMPv3 authentication key</b>	128 bits	Entered by Crypto-Officer	RAM, Flash memory
<b>Payload Encryption Private key</b>	ECDSA/ECDH P-224 or P-256 curve	Generated by module	Flash memory
<b>Payload Encryption DTLS tunnel keys</b>	256 bits Symmetric key	Generated by the module and established using DTLS.	RAM
<b>Payload Encryption DTLS HMAC keys</b>	160 bits Symmetric key	Generated by the module and established using DTLS.	RAM
<b>Payload encryption key</b>	128, 192 or 256 bits	Generated by module.	RAM
<b>Hash DRBG C and V CSP</b>	440 bits	Hash of entropy bits, nonce bits, and personalization string	RAM
<b>Hash DRBG Seed</b>	[Entropy seed]	Generated by NDRNG	RAM
<b>User Password</b>	8-32 characters	N/A	A hash of the password is stored persistently although the password itself is only held in RAM until authentication is completed
<b>Crypto-Officer Password</b>	8-32 characters	N/A	Not persistently stored, held in RAM until authentication is completed

Table 15: Key Table Part 1



KEY	ARE KEYS SUPPLIED ENCRYPTED OR PLAINTEXT?	ENTRY/OUTPUT	DESTRUCTION
<b>TLS Private key</b>	Plaintext	Generated in module, not entered. Not output.	Key is zeroized.
<b>TLS Tunnel keys</b>	Encrypted	Established using TLS	Key is zeroized.
<b>TLS HMAC keys</b>	Encrypted	Established using TLS	Key is zeroized.
<b>RADIUS shared secret</b>	Encrypted	Entered by Crypto-Officer through Craft tool. Not output	Key is overwritten. When the key is updated using portal, the new key is transmitted over TLS to the INU. The INU zeroizes the existing key in the encrypted key object. The INU then stores the new key in the encrypted key object. This key is used in all future requests to the RADIUS server. Encryption of the key is done using AES-128 in CBC mode.
<b>SNMPv3 privacy key</b>	Plaintext	Entered by Crypto-Officer through Craft tool. Not output	Key is overwritten. To zeroize the key, the CO needs to overwrite it by manually entering a new key.
<b>SNMPv3 authentication key</b>	Plaintext	Entered by Crypto-Officer through Craft tool. Not output.	Key is overwritten. To zeroize the key, the CO needs to overwrite it by manually entering a new key.
<b>Payload Encryption Private key</b>	Plaintext	The key neither enters nor leaves the module.	Key is zeroized.
<b>Payload Encryption DTLS Tunnel keys</b>	Encrypted	Established using DTLS	Key is zeroized
<b>Payload Encryption DTLS HMAC keys</b>	Encrypted	Established using DTLS	Key is zeroized
<b>Payload Encryption key</b>	Encrypted	Exchanged with peer module using existing DTLS tunnel	Key is zeroized
<b>Hash DRBG C and V</b>	Plaintext	N/A	Key is zeroized
<b>Hash DRBG Seed</b>	Plaintext	N/A	Key is zeroized
<b>User Password</b>	N/A	Entered by User during Craft Tool operator authentication. Not output.	Hashed passwords are stored to allow authentication. Actual passwords are zeroized once authentication is completed.
<b>Crypto-Officer Password</b>	N/A	Entered by Crypto-Officer during Craft Tool operator authentication. Not output.	Hashed passwords are stored to allow authentication. Actual passwords are zeroized once authentication is completed.

Table 16: Key Table Part 2

KEY	KEY LENGTH/STRENGTH	GENERATION/ESTABLISHMENT	STORAGE LOCATION
<b>TLS Certificate</b>	ECDSA/ECDH P-224 or P-256 curve	Generated by module	Flash memory.
<b>Payload Encryption Certificate</b>	ECDSA/ECDH P-224 or P-256 curve	Derived from private key	Flash memory.
<b>Integrity key</b>	2048-bit RSA certificate	Fixed key	Public integrity key will be stored within the module. The private key will not.

Table 17: Public Key Table Part 1

KEY	ARE KEYS SUPPLIED ENCRYPTED OR PLAINTEXT?	ENTRY/OUTPUT
<b>TLS Certificate</b>	Signed by ECDSA.	Generated in module, not entered. May be output.
<b>Payload Encryption Certificate</b>	Plaintext.	Generated in module, not entered. May be output.
<b>Integrity key</b>	Plaintext.	Fixed.

Table 18: Public Key Table Part 2

#### 2.7.4 CSP Destruction

All secret and private key material managed by the module can be zeroized using the key zeroization service. This is a Crypto-Officer service requiring Crypto-Officer authentication. CSP zeroization is performed procedurally and requires the Crypto-Officer to enter zero values for the manually entered CSPs (SNMPv3 passwords and RADIUS shared secret) and also perform the key zeroization service to zeroize the other secret and private keys. A reboot of the module is required to complete the CSP zeroization and the Crypto Office should remain in control of the module until the module self-tests have completed following the reboot.

#### 2.7.5 Access to Key Material

The following table shows the access that an operator has to specific keys or other critical security parameters when performing each of the services relevant to his/her role.

##### Access Rights

Blank Not Applicable  
 R Read  
 W Write  
 X Execute  
 Z Zeroize

KEY	TLS PRIVATE KEY	TLS TUNNEL KEYS	TLS HMAC KEYS	TLS CERTIFICATE	RADIUS SHARED SECRET	SNMPV3 PRIVACY KEY	SNMPV3 AUTHENTICATION KEY	CA PUBLIC KEY	CA CERTIFICATE	PAYLOAD ENCRYPTION CERTIFICATE	PAYLOAD ENCRYPTION PRIVATE KEY	PAYLOAD ENCRYPTION KEY	PAYLOAD ENCRYPTION DTLS TUNNEL KEYS	PAYLOAD ENCRYPTION DTLS HMAC KEYS	FIRMWARE INTEGRITY KEY	HASH DRBG " C" CSP	HASH DRBG " V" CSP	HASH DRBG SEED	USER PASSWORD	CRYPTO-OFFICER PASSWORD
<b>User Services</b>																				
View Configuration	R	R	R	R	R								R	R						
Craft Tool	R	R	R	R	R								R	R					X	
<b>Crypto-Officer Services</b>																				
Disable Payload Encryption	R	R	R	R	R								R	R						
Enable Payload Encryption	R	R	R	R	R								R	R						
Craft Tool	R	R	R	R	R								R	R						X
Firmware Upgrade															R					
Zeroize	Z	Z	Z		Z	Z	Z			Z	Z	Z	Z	Z		Z	Z	Z		
Key Management (Payload Encryption)								R	R	R	R	W				X	X	X		
Key Management (Secure Management)	R	R	R	R	R								R	R						
Module Configuration	R	R	R	R	R															
SNMP v3						R, W	R, W													
RADIUS					R, W															

KEY	TLS PRIVATE KEY	TLS TUNNEL KEYS	TLS HMAC KEYS	TLS CERTIFICATE	RADIUS SHARED SECRET	SNMPV3 PRIVACY KEY	SNMPV3 AUTHENTICATION KEY	CA PUBLIC KEY	CA CERTIFICATE	PAYLOAD ENCRYPTION CERTIFICATE	PAYLOAD ENCRYPTION PRIVATE KEY	PAYLOAD ENCRYPTION KEY	PAYLOAD ENCRYPTION DTLS TUNNEL KEYS	PAYLOAD ENCRYPTION DTLS HMAC KEYS	FIRMWARE INTEGRITY KEY	HASH DRBG " C" CSP	HASH DRBG " V" CSP	HASH DRBG SEED	USER PASSWORD	CRYPTO-OFFICER PASSWORD
View Status Request	R	R	R	R	R								R	R						
<b><u>Unauthenticated Services</u></b>												X								
Payload Encryption												X								
Payload Decryption																				
Perform Self-Tests		Z	Z													Z	Z	Z		
View Status indicators																				

Table 19: Access to Keys by Services

Note: Key zeroization zeroizes all keys and CSPs; this is a “write” operation in that all keys are overwritten with zeroes.

## 2.8 Self-Tests

The module implements both power-up and conditional self-tests as required by FIPS 140-2.

The following two sections outline the tests that are performed.

### 2.8.1 Power-up Self-tests

After power cycling or booting the appliance the module executes the Power-Up Self-Tests with no further inputs or actions by the operator.

The module implements the following power-up self-tests. The module inhibits all data output while it is operating in the Self-Test state.

OBJECT	TEST
<b>AES (#C1)</b>	AES-128-CBC Encrypt Known answer test AES-256-CBC Encrypt Known answer test AES-256-CFB128 Encrypt Known answer test AES-128-CBC Decrypt Known answer test AES-256-CBC Decrypt Known answer test AES-256-CFB128 Decrypt Known answer test
<b>AES (#C5)</b>	AES-128-CCM Encrypt Known answer test AES-192-CCM Encrypt Known answer test AES-256-CCM Encrypt Known answer test
<b>RSA</b>	Known answer test (signature verification; RSA Cert. #C1)
<b>ECDSA</b>	Known answer test (signature generation) Known answer test (signature verification)
<b>DRBG</b>	SP 800-90A Hash-based DRBG Known answer test SP 800-90A Section 11.3 Health Tests
<b>ECCCDH</b>	Performs an ECCCDH KAT using a NIST defined P-256 curve.
<b>Bootloader</b>	Integrity test performed by verifying the RSA-2048 signature of a SHA-256 hash of the bootloader image (RSA Cert. #2239; SHS Cert. #3397)
<b>Module firmware</b>	Firmware Integrity test performed by verifying the RSA-2048 signature of a SHA-256 hash of the firmware image (RSA Cert. #C1; SHS Cert. #C1)
<b>HMAC-SHA-1</b>	Known answer test (SHS Cert. #C1)
<b>HMAC-SHA-256</b>	Known answer test (SHS Cert. #C1)
<b>SHA-1</b>	Known answer test (SHS Cert. #C1)

Table 20: Power-up Self-Tests

Note: For historical reasons, the module also performs an RSA signature generation known answer test at power-up, but the module no longer uses RSA signature generation in an Approved mode of operation.

## 2.8.2 Conditional Self-tests

EVENT	TEST	CONSEQUENCE OF FAILURE
Module requests a random number from the FIPS Approved SP 800-90A DRBG	A continuous random number generator test	Random number is not generated and module enters an error state
Entropy is supplied to the FIPS Approved SP 800-90A Hash-based DRBG	A continuous random number generator test on the entropy NDRNG	Entropy is not added and module enters an error state
Firmware upgrade	Firmware load test – Approved integrity technique using SHA-256 and RSA. (RSA Cert. #C1; SHS Cert. #C1)	Firmware upgrade fails
Manual key entry test	Duplicate entries	Key not loaded
Asymmetric key pair generated	ECDSA Pairwise Consistency test	Key rejected and module enters an error state
RAC enters switches between a bypass mode and cryptographic mode of operation	Exclusive Bypass test – two independent actions are required to change mode (encrypted to bypass and vice versa) and test the correct operation of the services providing cryptographic processing when the switch occurs	RAC is disabled and no data is passed

**Table 21: Conditional Self-Tests**

## 2.9 Design Assurance

Aviat Networks employ industry standard best practices in the design, development, production and maintenance of the Aviat Networks Eclipse product, including the FIPS 140-2 module.

Aviat Networks has an ISO 9001 Quality Management System.

This includes the use of an industry standard configuration management system that is operated in accordance with the requirements of FIPS 140-2, such that each configuration item that forms part of the module is stored with a label corresponding to the version of the module and that the module and all of its associated documentation can be regenerated from the configuration management system with reference to the relevant version number.

Design documentation for the module is maintained to provide clear and consistent information within the document hierarchy to enable transparent traceability between corresponding areas throughout the document hierarchy, for instance, between elements of this Cryptographic Module Security Policy (CMSP) and the design documentation.

Guidance appropriate to an operator's Role is provided with the module and provides all of the necessary assistance to enable the secure operation of the module by an operator, including the Approved security functions of the module.

Delivery of the Cryptographic Module to customers from the vendor is via third party couriers. The parcels are sealed in tamper evident packaging and each parcel is tracked from vendor to customer. Once on site, the customer must follow vendor guidance to securely install and configure the module.

## **2.10 Mitigation of Other Attacks**

The module does not mitigate any other attacks.

### 3 FIPS Mode of Operation

Once the module has been commissioned, the front panel of the module should be sealed, with no visible gaps and tamper evident seals applied as described in section 2.5 above.

The module is set into FIPS mode as follows:

1. Install FIPS capable NCC with CF card containing FIPS validated firmware
2. Power up NCC
3. Connect to NCC with Portal
4. Install S/W license containing Strong Security, FIPS compliance, and optional Payload Encryption
5. Set security mode to "FIPS"
6. Select "Yes" when Portal asks for confirmation
7. NCC reboots
8. Connect to NCC using Portal
9. Log in to NCC using a default Crypto-Officer
10. Configure desired security settings and add local users and/or RADIUS servers as required
11. By default Payload Encryption is disabled, Bypass warning alarm raised against RAC
12. Log in as a user with Crypto-Officer permissions
13. Perform other RAC and Payload Encryption configuration and enable Payload Encryption

The use of the Approved mode locks out the use of non-Approved algorithms.

For more details, please see the Eclipse User Manual Addendum for FIPS 140-2.