



**SUSE LLC**

**SUSE Linux Enterprise OpenSSL 3 Cryptographic  
Module**

**FIPS 140-3 Non-Proprietary Security Policy**

**Prepared by:**

atsec information security corporation  
4516 Seton Center Pkwy, Suite 250  
Austin, TX 78759  
[www.atsec.com](http://www.atsec.com)

**Document version:** 1.2  
**Last update:** 15-12-2025

# Table of Contents

1 General.....	6
1.1 Overview.....	6
1.1.1 How this Security Policy was prepared.....	6
1.2 Security Levels.....	6
2 Cryptographic Module Specification.....	8
2.1 Description.....	8
2.2 Tested and Vendor Affirmed Module Version and Identification.....	9
2.3 Excluded Components.....	13
2.4 Modes of Operation.....	13
2.5 Algorithms.....	14
2.6 Security Function Implementations.....	50
2.7 Algorithm Specific Information.....	65
2.7.1 AES GCM IV.....	65
2.7.2 AES XTS.....	65
2.7.3 Key Derivation using SP 800-132 PBKDF2.....	65
2.7.4 SP 800-56A Rev. 3 Assurances.....	66
2.7.5 SHA-3.....	66
2.7.6 RSA Signatures.....	66
2.7.7 RSA Key Agreement.....	67
2.7.8 Compliance to SP 800-56Br2 Assurances.....	67
2.7.9 Key Transport and Key Agreement.....	67
2.7.10 SHA-1 Use.....	67
2.8 RBG and Entropy.....	67
2.9 Key Generation.....	68
2.10 Key Establishment.....	68
2.11 Industry Protocols.....	69
3 Cryptographic Module Interfaces.....	70
3.1 Ports and Interfaces.....	70
4 Roles, Services, and Authentication.....	71
4.1 Authentication Methods.....	71
4.2 Roles.....	71
4.3 Approved Services.....	71
4.4 Non-Approved Services.....	84
4.5 External Software/Firmware Loaded.....	85

© 2025 SUSE, LLC/atsec information security corporation.

This document can be reproduced and distributed only whole and intact, including this copyright notice.

5 Software/Firmware Security .....	86
5.1 Integrity Techniques .....	86
5.2 Initiate on Demand .....	86
6 Operational Environment .....	87
6.1 Operational Environment Type and Requirements .....	87
6.2 Configuration Settings and Restrictions .....	87
7 Physical Security .....	88
8 Non-Invasive Security .....	89
9 Sensitive Security Parameters Management .....	90
9.1 Storage Areas .....	90
9.2 SSP Input-Output Methods .....	90
9.3 SSP Zeroization Methods .....	90
9.4 SSPs .....	92
9.5 Transitions .....	103
10 Self-Tests .....	104
10.1 Pre-Operational Self-Tests .....	104
10.2 Conditional Self-Tests .....	106
10.3 Periodic Self-Test Information .....	127
10.4 Error States .....	139
10.5 Operator Initiation of Self-Tests .....	140
11 Life-Cycle Assurance .....	141
11.1 Installation, Initialization, and Startup Procedures .....	141
11.2 Administrator Guidance .....	141
11.3 Non-Administrator Guidance .....	142
11.4 End of Life .....	142
12 Mitigation of Other Attacks .....	143
12.1 Attack List .....	143
Appendix A. Glossary and Abbreviations .....	144
Appendix B. References .....	146

## List of Tables

Table 1: Security Levels .....	<b>Error! Bookmark not defined.</b>
Table 2: Tested Module Identification - Hardware.....	<b>Error! Bookmark not defined.</b>
Table 3: Tested Module Identification - Software/Firmware/Hybrid (Executable Code Sets) .....	<b>Error! Bookmark not defined.</b>
Table 4: Tested Module Identification - Hybrid Disjoint Hardware.....	<b>Error! Bookmark not defined.</b>
Table 5: Tested Operational Environments - Software, Firmware, Hybrid ....	<b>Error! Bookmark not defined.</b>
Table 6: Vendor Affirmed Operational Environments - Software, Firmware, Hybrid.....	<b>Error! Bookmark not defined.</b>
Table 7: Modes List and Description .....	<b>Error! Bookmark not defined.</b>
Table 8: Approved Algorithms.....	<b>Error! Bookmark not defined.</b>
Table 9: Vendor Affirmed Algorithms.....	<b>Error! Bookmark not defined.</b>
Table 10: Non-Approved, Allowed Algorithms .....	<b>Error! Bookmark not defined.</b>
Table 11: Non-Approved, Allowed Algorithms with No Security Claimed .....	<b>Error! Bookmark not defined.</b>
Table 12: Non-Approved, Not Allowed Algorithms.....	<b>Error! Bookmark not defined.</b>
Table 13: Security Function Implementations .....	<b>Error! Bookmark not defined.</b>
Table 14: Entropy Certificates.....	<b>Error! Bookmark not defined.</b>
Table 15: Entropy Sources .....	<b>Error! Bookmark not defined.</b>
Table 16: Key Generation.....	<b>Error! Bookmark not defined.</b>
Table 17: Key Agreement.....	<b>Error! Bookmark not defined.</b>
Table 18: Key Transport.....	<b>Error! Bookmark not defined.</b>
Table 19: Ports and Interfaces .....	<b>Error! Bookmark not defined.</b>
Table 20: Authentication Methods .....	<b>Error! Bookmark not defined.</b>
Table 21: Roles.....	<b>Error! Bookmark not defined.</b>
Table 22: Approved Services .....	<b>Error! Bookmark not defined.</b>
Table 23: Non-Approved Services.....	<b>Error! Bookmark not defined.</b>
Table 24: Mechanisms and Actions Required .....	<b>Error! Bookmark not defined.</b>
Table 25: EFP/EFT Information .....	<b>Error! Bookmark not defined.</b>
Table 26: Hardness Testing Temperatures .....	<b>Error! Bookmark not defined.</b>
Table 27: Storage Areas.....	<b>Error! Bookmark not defined.</b>
Table 28: SSP Input-Output.....	<b>Error! Bookmark not defined.</b>
Table 29: SSP Zeroization Methods.....	<b>Error! Bookmark not defined.</b>
Table 30: SSP Information First.....	<b>Error! Bookmark not defined.</b>

Table 31: SSP Information Second ..... **Error! Bookmark not defined.**  
Table 32: Pre-Operational Self-Tests..... **Error! Bookmark not defined.**  
Table 33: Conditional Self-Tests..... **Error! Bookmark not defined.**  
Table 34: Pre-Operational Periodic Information ..... **Error! Bookmark not defined.**  
Table 35: Conditional Periodic Information ..... **Error! Bookmark not defined.**  
Table 36: Error States ..... **Error! Bookmark not defined.**

## List of Figures

Figure 1: Block Diagram..... 9

# 1 General

## 1.1 Overview

This document is the non-proprietary FIPS 140-3 Security Policy for version 1.0 of the SUSE Linux Enterprise OpenSSL 3 Cryptographic Module. It contains the security rules under which the module must operate and describes how this module meets the requirements as specified in FIPS PUB 140-3 (Federal Information Processing Standards Publication 140-3) for an overall Security Level 1 module.

This Non-Proprietary Security Policy may be reproduced and distributed, but only whole and intact and including this notice. Other documentation is proprietary to their authors.

### 1.1.1 How this Security Policy was prepared

In preparing the Security Policy document, the laboratory formatted the vendor-supplied documentation for consolidation without altering the technical statements therein contained. The further refining of the Security Policy document was conducted iteratively throughout the conformance testing, wherein the Security Policy was submitted to the vendor, who would then edit, modify, and add technical contents. The vendor would also supply additional documentation, which the laboratory formatted into the existing Security Policy, and resubmitted to the vendor for their final editing.

## 1.2 Security Levels

Section	Title	Security Level
1	General	1
2	Cryptographic module specification	1
3	Cryptographic module interfaces	1
4	Roles, services, and authentication	1
5	Software/Firmware security	1
6	Operational environment	1
7	Physical security	N/A
8	Non-invasive security	N/A
9	Sensitive security parameter management	1
10	Self-tests	1
11	Life-cycle assurance	1
12	Mitigation of other attacks	1
	Overall Level	1

Table 1: Security Levels

## 2 Cryptographic Module Specification

### 2.1 Description

**Purpose and Use:**

The SUSE Linux Enterprise OpenSSL 3 Cryptographic Module (hereafter referred to as “the module”) is defined as a software module in a multi-chip standalone embodiment. It provides a C language application program interface (API) for use by other applications that require cryptographic functionality. The module is a software library supporting FIPS 140-3 approved algorithms developed by SUSE LLC for its use by other applications that require cryptographic functionality and consists of one software component, the “FIPS provider”, which implements the FIPS requirements and the cryptographic functionality provided to the operator.

**Module Type:** Software**Module Embodiment:** Multi-Chip Standalone**Cryptographic Boundary:**

The cryptographic boundary of the module is defined as the fips.so shared library, which contains the compiled code implementing the FIPS provider.

**Tested Operational Environment’s Physical Perimeter (TOEPP):**

The TOEPP of the module is defined as the general-purpose computer on which the module is installed.

Figure 1 shows a block diagram that represents the design of the module when the module is operational and providing services to other user space applications. In this diagram, the physical perimeter of the operational environment (a general-purpose computer on which the module is installed) is indicated by a purple dashed line. The cryptographic boundary is represented by the components painted in orange blocks, which consists only of the shared library implementing the FIPS provider (fips.so).

The “Data/Control Input” and “Data/Status Output” arrows indicate the flow of data between the cryptographic module and its operator application, through the logical interfaces defined in Section 3 Cryptographic Module Interfaces.

Components in white are only included in the diagram for informational purposes. They are not included in the cryptographic boundary (and therefore not part of the module’s validation). For example, the kernel is responsible for managing system calls issued by the module itself, as well as other applications using the module for cryptographic services.

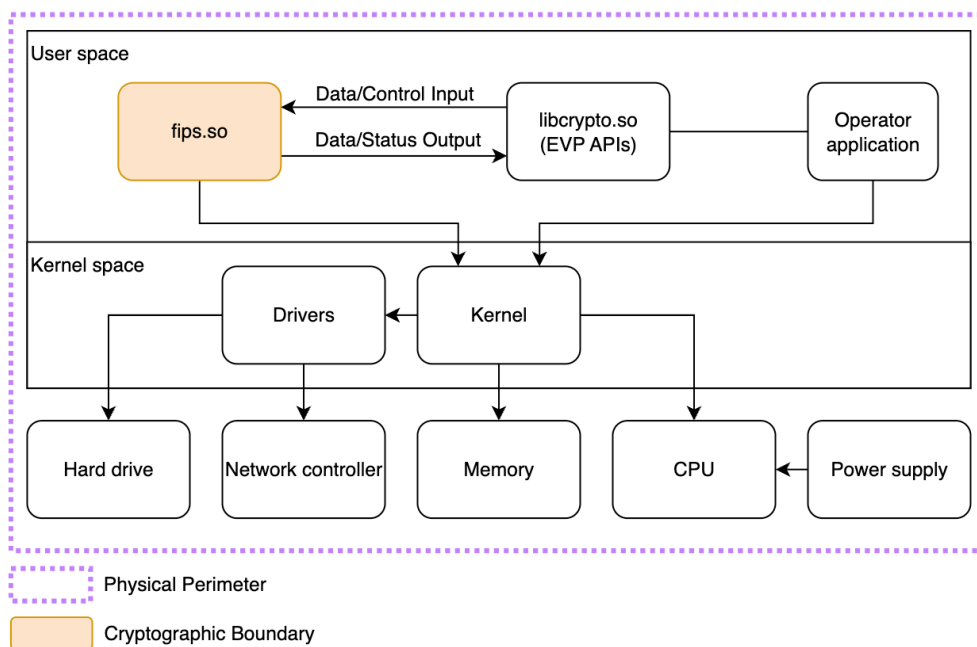

Figure 1: Block Diagram

## 2.2 Tested and Vendor Affirmed Module Version and Identification

### Tested Module Identification - Hardware:

N/A for this module.

### Tested Module Identification - Software, Firmware, Hybrid (Executable Code Sets):

Package or File Name	Software/ Firmware Version	Features	Integrity Test
fips.so on SUSE Linux Enterprise Server 15 SP6 and AMD EPYC™ 7343	1.0	N/A	HMAC-SHA2-256
fips.so on SUSE Linux Enterprise Server 15 SP6 and Intel® Xeon® Gold 5416S	1.0	N/A	HMAC-SHA2-256
fips.so on SUSE Linux Enterprise Server 15 SP6 and IBM® Telum™	1.0	N/A	HMAC-SHA2-256

Package or File Name	Software/ Firmware Version	Features	Integrity Test
fips.so on SUSE Linux Enterprise Server 15 SP6 and Ampere® Altra® Q80-30	1.0	N/A	HMAC-SHA2-256

Table 2: Tested Module Identification - Software, Firmware, Hybrid (Executable Code Sets)

**Tested Module Identification - Hybrid Disjoint Hardware:**

N/A for this module.

**Tested Operational Environments - Software, Firmware, Hybrid:**

Operating System	Hardware Platform	Processors	PAA/PAI	Hypervisor or Host OS	Version(s)
SUSE Linux Enterprise Server 15 SP6	SuperMicro SuperChassis 825BTQC-R1K23LPB and Motherboard H12DSi-NT6	AMD EPYC™ 7343	Yes	N/A	1.0
SUSE Linux Enterprise Server 15 SP6	SuperMicro SuperChassis 825BTQC-R1K23LPB and Motherboard H12DSi-NT6	AMD EPYC™ 7343	No	N/A	1.0
SUSE Linux Enterprise Server 15 SP6	GIGABYTE R152-P30	Ampere® Altra® Q80-30	Yes	N/A	1.0
SUSE Linux Enterprise Server 15 SP6	GIGABYTE R152-P30	Ampere® Altra® Q80-30	No	N/A	1.0
SUSE Linux Enterprise Server 15 SP6	IBM z16 A01	IBM® Telum™	Yes	N/A	1.0
SUSE Linux Enterprise	IBM z16 A01	IBM® Telum™	No	N/A	1.0

© 2025 SUSE, LLC/atsec information security corporation.

This document can be reproduced and distributed only whole and intact, including this copyright notice.

Operating System	Hardware Platform	Processors	PAA/PAI	Hypervisor or Host OS	Version(s)
Server 15 SP6					
SUSE Linux Enterprise Server 15 SP6	ASUS RS700-E11-RS4U	Intel® Xeon® Gold 5416S	Yes	N/A	1.0
SUSE Linux Enterprise Server 15 SP6	ASUS RS700-E11-RS4U	Intel® Xeon® Gold 5416S	No	N/A	1.0

Table 3: Tested Operational Environments - Software, Firmware, Hybrid

**Vendor-Affirmed Operational Environments - Software, Firmware, Hybrid:**

Operating System	Hardware Platform
SUSE Linux Enterprise Server for SAP 15SP6	ASUS RS700-E11-RS4U on Intel® Xeon® Gold 5416S
SUSE Linux Enterprise Desktop 15SP6	ASUS RS700-E11-RS4U on Intel® Xeon® Gold 5416S
SUSE Linux Enterprise Base Container Image 15SP6	ASUS RS700-E11-RS4U on Intel® Xeon® Gold 5416S
SUSE Linux Enterprise Server for SAP 15SP6	SuperMicro SuperChassis 825BTQCR1K23LPB and Motherboard H12DSi-NT6 on AMD EPYC™ 7343
SUSE Linux Enterprise Desktop 15SP6	SuperMicro SuperChassis 825BTQCR1K23LPB and Motherboard H12DSi-NT6 on AMD EPYC™ 7343
SUSE Linux Enterprise Base Container Image 15SP6	SuperMicro SuperChassis 825BTQCR1K23LPB and Motherboard H12DSi-NT6 on AMD EPYC™ 7343
SUSE Linux Enterprise Server for SAP 15SP6	IBM z16 A01 on IBM® Telum™
SUSE Linux Enterprise Base Container Image 15SP6	IBM z16 A01 on IBM® Telum™
SUSE Linux Enterprise Server 15SP6	IBM LinuxONE III Model LT1 QEMU VM on z15
SUSE Linux Enterprise Base Container Image 15SP6	IBM LinuxONE III Model LT1 QEMU VM on z15

© 2025 SUSE, LLC/atsec information security corporation.

This document can be reproduced and distributed only whole and intact, including this copyright notice.

<b>Operating System</b>	<b>Hardware Platform</b>
SUSE Linux Enterprise Server Real Time 15SP6	QEMU VM on AMD EPYC™ 7773X
SUSE Linux Enterprise Server for SAP 15SP6	QEMU VM on AMD EPYC™ 7773X
SUSE Linux Enterprise Base Container Image 15SP6	QEMU VM on AMD EPYC™ 7773X
SUSE Linux Enterprise Server 15SP6	QEMU VM on AMD EPYC™ 7773X
SUSE Linux Enterprise Desktop 15SP6	QEMU VM on Intel® i7-1195G7
SUSE Linux Enterprise Base Container Image 15SP6	GIGABYTE R152-P30 on Ampere® Altra® Q80-30
SUSE Linux Enterprise Server for SAP 15SP6	QEMU VM on Ampere® Altra® Q80-30
SUSE Linux Enterprise Base Container Image 15SP6	QEMU VM on Ampere® Altra® Q80-30
SUSE Linux Enterprise Server 15SP6	QEMU VM on Ampere® Altra® Q80-30
SUSE Linux Enterprise Server 15SP6	QEMU VM on Intel® Xeon® Gold 6338
SUSE Linux Enterprise Server for SAP 15SP6	QEMU VM on Intel® Xeon® Gold 5218R
SUSE Linux Enterprise Server for SAP 15SP7	ASUS RS700-E11-RS4U on Intel® Xeon® Gold 5416S
SUSE Linux Enterprise Server for SAP 15SP7	SuperMicro SuperChassis 825BTQCR1K23LPB and Motherboard H12DSi-NT6 on AMD EPYC™ 7343
SUSE Linux Enterprise Desktop 15SP7	ASUS RS700-E11-RS4U on Intel® Xeon® Gold 5416S
SUSE Linux Enterprise Desktop 15SP7	SuperMicro SuperChassis 825BTQCR1K23LPB and Motherboard H12DSi-NT6 on AMD EPYC™ 7343
SUSE Linux Enterprise Base Container Image 15SP7	ASUS RS700-E11-RS4U on Intel® Xeon® Gold 5416S

Operating System	Hardware Platform
SUSE Linux Enterprise Base Container Image 15SP7	SuperMicro SuperChassis 825BTQCR1K23LPB and Motherboard H12DSi-NT6 on AMD EPYC™ 7343
SUSE Linux Enterprise Base Container Image 15SP7	GIGABYTE R152-P30 on Ampere® Altra® Q80-30
SUSE Linux Enterprise Base Container Image 15SP7	IBM z16 A01 on IBM® Telum™
SUSE Linux Enterprise Base Container Image 15SP7	IBM LinuxONE III Model LT1 on z15
SUSE Linux Enterprise Server 15SP7	IBM LinuxONE III Model LT1 on z15
SUSE Linux Enterprise Server 15SP7	IBM z16 A01 on IBM® Telum™
SUSE Linux Enterprise Server 15SP7	ASUS RS700-E11-RS4U on Intel® Xeon® Gold 5416S
SUSE Linux Enterprise Server 15SP7	SuperMicro SuperChassis 825BTQCR1K23LPB and Motherboard H12DSi-NT6 on AMD EPYC™ 7343
SUSE Linux Enterprise Server 15SP7	GIGABYTE R152-P30 on Ampere® Altra® Q80-30

Table 4: Vendor-Affirmed Operational Environments - Software, Firmware, Hybrid

The module is considered to maintain compliance with the FIPS 140-3 validation for SUSE products when operating on any general-purpose platform/processor that supports the SUSE Linux Enterprise Server operating system per the vendor affirmation from SUSE based on the allowance FIPS 140-3 management manual [FIPS140-3\_MM] section 7.9.1 bullet 1 a i).

CMVP makes no statement as to the correct operation of the module or the security strengths of the generated keys when so ported if the specific operational environment is not listed on the validation certificate.

## 2.3 Excluded Components

There are no components excluded from the requirements of the FIPS 140-3 standard.

## 2.4 Modes of Operation

### Modes List and Description:

Mode Name	Description	Type	Status Indicator
Approved mode	Automatically entered whenever an approved service is requested	Approved	Equivalent to the indicator of the requested service
Non-approved mode	Automatically entered whenever a non-approved service is requested	Non-Approved	Equivalent to the indicator of the requested service

Table 5: Modes List and Description

After passing all pre-operational self-tests and cryptographic algorithm self-tests executed on start-up, the module automatically transitions to the approved mode. No operator intervention is required to reach this point. The module operates in the approved mode of operation by default and can only transition into the non-approved mode by calling one of the non-approved services listed in the Non-Approved Services table of the Security Policy.

In the operational state, the module accepts service requests from calling applications through its logical interfaces. At any point in the operational state, a calling application can end its process, causing the module to end its operation.

#### Mode Change Instructions and Status:

The module automatically switches between the approved and non-approved modes depending on the services requested by the operator. The status indicator of the mode of operation is equivalent to the indicator of the service that was requested.

## 2.5 Algorithms

### Approved Algorithms:

Algorithm	CAVP Cert	Properties	Reference
AES-CBC	A5398	Direction - Decrypt, Encrypt Key Length - 128, 192, 256	SP 800-38A
AES-CBC	A5399	Direction - Decrypt, Encrypt Key Length - 128, 192, 256	SP 800-38A
AES-CBC	A5400	Direction - Decrypt, Encrypt Key Length - 128, 192, 256	SP 800-38A
AES-CBC	A5401	Direction - Decrypt, Encrypt Key Length - 128, 192, 256	SP 800-38A
AES-CBC	A5402	Direction - Decrypt, Encrypt Key Length - 128, 192, 256	SP 800-38A
AES-CBC	A5403	Direction - Decrypt, Encrypt Key Length - 128, 192, 256	SP 800-38A

<b>Algorithm</b>	<b>CAVP Cert</b>	<b>Properties</b>	<b>Reference</b>
AES-CBC	A5658	Direction - Decrypt, Encrypt Key Length - 128, 192, 256	SP 800-38A
AES-CBC-CS1	A5398	Direction - decrypt, encrypt Key Length - 128, 192, 256	SP 800-38A
AES-CBC-CS1	A5399	Direction - decrypt, encrypt Key Length - 128, 192, 256	SP 800-38A
AES-CBC-CS1	A5400	Direction - decrypt, encrypt Key Length - 128, 192, 256	SP 800-38A
AES-CBC-CS1	A5401	Direction - decrypt, encrypt Key Length - 128, 192, 256	SP 800-38A
AES-CBC-CS1	A5402	Direction - decrypt, encrypt Key Length - 128, 192, 256	SP 800-38A
AES-CBC-CS1	A5403	Direction - decrypt, encrypt Key Length - 128, 192, 256	SP 800-38A
AES-CBC-CS1	A5658	Direction - decrypt, encrypt Key Length - 128, 192, 256	SP 800-38A
AES-CBC-CS2	A5398	Direction - decrypt, encrypt Key Length - 128, 192, 256	SP 800-38A
AES-CBC-CS2	A5399	Direction - decrypt, encrypt Key Length - 128, 192, 256	SP 800-38A
AES-CBC-CS2	A5400	Direction - decrypt, encrypt Key Length - 128, 192, 256	SP 800-38A
AES-CBC-CS2	A5401	Direction - decrypt, encrypt Key Length - 128, 192, 256	SP 800-38A
AES-CBC-CS2	A5402	Direction - decrypt, encrypt Key Length - 128, 192, 256	SP 800-38A
AES-CBC-CS2	A5403	Direction - decrypt, encrypt Key Length - 128, 192, 256	SP 800-38A
AES-CBC-CS2	A5658	Direction - decrypt, encrypt Key Length - 128, 192, 256	SP 800-38A
AES-CBC-CS3	A5398	Direction - decrypt, encrypt Key Length - 128, 192, 256	SP 800-38A

<b>Algorithm</b>	<b>CAVP Cert</b>	<b>Properties</b>	<b>Reference</b>
AES-CBC-CS3	A5399	Direction - decrypt, encrypt Key Length - 128, 192, 256	SP 800-38A
AES-CBC-CS3	A5400	Direction - decrypt, encrypt Key Length - 128, 192, 256	SP 800-38A
AES-CBC-CS3	A5401	Direction - decrypt, encrypt Key Length - 128, 192, 256	SP 800-38A
AES-CBC-CS3	A5402	Direction - decrypt, encrypt Key Length - 128, 192, 256	SP 800-38A
AES-CBC-CS3	A5403	Direction - decrypt, encrypt Key Length - 128, 192, 256	SP 800-38A
AES-CBC-CS3	A5658	Direction - decrypt, encrypt Key Length - 128, 192, 256	SP 800-38A
AES-CCM	A5398	Key Length - 128, 192, 256	SP 800-38C
AES-CCM	A5399	Key Length - 128, 192, 256	SP 800-38C
AES-CCM	A5400	Key Length - 128, 192, 256	SP 800-38C
AES-CCM	A5401	Key Length - 128, 192, 256	SP 800-38C
AES-CCM	A5402	Key Length - 128, 192, 256	SP 800-38C
AES-CCM	A5403	Key Length - 128, 192, 256	SP 800-38C
AES-CCM	A5658	Key Length - 128, 192, 256	SP 800-38C
AES-CFB1	A5398	Direction - Decrypt, Encrypt Key Length - 128, 192, 256	SP 800-38A
AES-CFB1	A5399	Direction - Decrypt, Encrypt Key Length - 128, 192, 256	SP 800-38A
AES-CFB1	A5400	Direction - Decrypt, Encrypt Key Length - 128, 192, 256	SP 800-38A
AES-CFB1	A5401	Direction - Decrypt, Encrypt Key Length - 128, 192, 256	SP 800-38A
AES-CFB1	A5402	Direction - Decrypt, Encrypt Key Length - 128, 192, 256	SP 800-38A

<b>Algorithm</b>	<b>CAVP Cert</b>	<b>Properties</b>	<b>Reference</b>
AES-CFB1	A5403	Direction - Decrypt, Encrypt Key Length - 128, 192, 256	SP 800-38A
AES-CFB1	A5658	Direction - Decrypt, Encrypt Key Length - 128, 192, 256	SP 800-38A
AES-CFB128	A5398	Direction - Decrypt, Encrypt Key Length - 128, 192, 256	SP 800-38A
AES-CFB128	A5399	Direction - Decrypt, Encrypt Key Length - 128, 192, 256	SP 800-38A
AES-CFB128	A5400	Direction - Decrypt, Encrypt Key Length - 128, 192, 256	SP 800-38A
AES-CFB128	A5401	Direction - Decrypt, Encrypt Key Length - 128, 192, 256	SP 800-38A
AES-CFB128	A5402	Direction - Decrypt, Encrypt Key Length - 128, 192, 256	SP 800-38A
AES-CFB128	A5403	Direction - Decrypt, Encrypt Key Length - 128, 192, 256	SP 800-38A
AES-CFB128	A5658	Direction - Decrypt, Encrypt Key Length - 128, 192, 256	SP 800-38A
AES-CFB8	A5398	Direction - Decrypt, Encrypt Key Length - 128, 192, 256	SP 800-38A
AES-CFB8	A5399	Direction - Decrypt, Encrypt Key Length - 128, 192, 256	SP 800-38A
AES-CFB8	A5400	Direction - Decrypt, Encrypt Key Length - 128, 192, 256	SP 800-38A
AES-CFB8	A5401	Direction - Decrypt, Encrypt Key Length - 128, 192, 256	SP 800-38A
AES-CFB8	A5402	Direction - Decrypt, Encrypt Key Length - 128, 192, 256	SP 800-38A
AES-CFB8	A5403	Direction - Decrypt, Encrypt Key Length - 128, 192, 256	SP 800-38A
AES-CFB8	A5658	Direction - Decrypt, Encrypt Key Length - 128, 192, 256	SP 800-38A

<b>Algorithm</b>	<b>CAVP Cert</b>	<b>Properties</b>	<b>Reference</b>
AES-CMAC	A5398	Capabilities - Direction - Generation, Verification Key Length - 128, 192, 256	SP 800-38B
AES-CMAC	A5399	Capabilities - Direction - Generation, Verification Key Length - 128, 192, 256	SP 800-38B
AES-CMAC	A5400	Capabilities - Direction - Generation, Verification Key Length - 128, 192, 256	SP 800-38B
AES-CMAC	A5401	Capabilities - Direction - Generation, Verification Key Length - 128, 192, 256	SP 800-38B
AES-CMAC	A5402	Capabilities - Direction - Generation, Verification Key Length - 128, 192, 256	SP 800-38B
AES-CMAC	A5403	Capabilities - Direction - Generation, Verification Key Length - 128, 192, 256	SP 800-38B
AES-CMAC	A5658	Capabilities - Direction - Generation, Verification Key Length - 128, 192, 256	SP 800-38B
AES-CTR	A5398	Direction - Decrypt, Encrypt Key Length - 128, 192, 256	SP 800-38A
AES-CTR	A5399	Direction - Decrypt, Encrypt Key Length - 128, 192, 256	SP 800-38A
AES-CTR	A5400	Direction - Decrypt, Encrypt Key Length - 128, 192, 256	SP 800-38A
AES-CTR	A5401	Direction - Decrypt, Encrypt Key Length - 128, 192, 256	SP 800-38A
AES-CTR	A5402	Direction - Decrypt, Encrypt Key Length - 128, 192, 256	SP 800-38A
AES-CTR	A5403	Direction - Decrypt, Encrypt Key Length - 128, 192, 256	SP 800-38A
AES-CTR	A5658	Direction - Decrypt, Encrypt Key Length - 128, 192, 256	SP 800-38A

<b>Algorithm</b>	<b>CAVP Cert</b>	<b>Properties</b>	<b>Reference</b>
AES-ECB	A5398	Direction - Decrypt, Encrypt Key Length - 128, 192, 256	SP 800-38A
AES-ECB	A5399	Direction - Decrypt, Encrypt Key Length - 128, 192, 256	SP 800-38A
AES-ECB	A5400	Direction - Decrypt, Encrypt Key Length - 128, 192, 256	SP 800-38A
AES-ECB	A5401	Direction - Decrypt, Encrypt Key Length - 128, 192, 256	SP 800-38A
AES-ECB	A5402	Direction - Decrypt, Encrypt Key Length - 128, 192, 256	SP 800-38A
AES-ECB	A5403	Direction - Decrypt, Encrypt Key Length - 128, 192, 256	SP 800-38A
AES-ECB	A5658	Direction - Decrypt, Encrypt Key Length - 128, 192, 256	SP 800-38A
AES-ECB	A5884	Direction - Decrypt, Encrypt Key Length - 128, 192, 256	SP 800-38A
AES-ECB	A5893	Direction - Decrypt, Encrypt Key Length - 128, 192, 256	SP 800-38A
AES-ECB	A5894	Direction - Decrypt, Encrypt Key Length - 128, 192, 256	SP 800-38A
AES-ECB	A5895	Direction - Decrypt, Encrypt Key Length - 128, 192, 256	SP 800-38A
AES-ECB	A5896	Direction - Decrypt, Encrypt Key Length - 128, 192, 256	SP 800-38A
AES-ECB	A5900	Direction - Decrypt, Encrypt Key Length - 128, 192, 256	SP 800-38A
AES-GCM	A5870	Direction - Decrypt, Encrypt IV Generation - External, Internal Key Length - 128, 192, 256 IV Generation Mode - 8.2.2	SP 800-38D
AES-GCM	A5871	Direction - Decrypt, Encrypt IV Generation - External, Internal Key Length - 128, 192, 256 IV Generation Mode - 8.2.2	SP 800-38D

<b>Algorithm</b>	<b>CAVP Cert</b>	<b>Properties</b>	<b>Reference</b>
AES-GCM	A5872	Direction - Decrypt, Encrypt IV Generation - External, Internal Key Length - 128, 192, 256 IV Generation Mode - 8.2.2	SP 800-38D
AES-GCM	A5873	Direction - Decrypt, Encrypt IV Generation - External, Internal Key Length - 128, 192, 256 IV Generation Mode - 8.2.2	SP 800-38D
AES-GCM	A5874	Direction - Decrypt, Encrypt IV Generation - External, Internal Key Length - 128, 192, 256 IV Generation Mode - 8.2.2	SP 800-38D
AES-GCM	A5875	Direction - Decrypt, Encrypt IV Generation - External, Internal Key Length - 128, 192, 256 IV Generation Mode - 8.2.2	SP 800-38D
AES-GCM	A5880	Direction - Decrypt, Encrypt IV Generation - External, Internal Key Length - 128, 192, 256 IV Generation Mode - 8.2.2	SP 800-38D
AES-GCM	A5881	Direction - Decrypt, Encrypt IV Generation - External, Internal Key Length - 128, 192, 256 IV Generation Mode - 8.2.2	SP 800-38D
AES-GCM	A5882	Direction - Decrypt, Encrypt IV Generation - External, Internal Key Length - 128, 192, 256 IV Generation Mode - 8.2.2	SP 800-38D
AES-GCM	A5886	Direction - Decrypt, Encrypt IV Generation - External, Internal Key Length - 128, 192, 256 IV Generation Mode - 8.2.2	SP 800-38D
AES-GCM	A5887	Direction - Decrypt, Encrypt IV Generation - External, Internal Key Length - 128, 192, 256 IV Generation Mode - 8.2.2	SP 800-38D
AES-GCM	A5888	Direction - Decrypt, Encrypt IV Generation - External, Internal Key Length - 128, 192, 256 IV Generation Mode - 8.2.2	SP 800-38D

<b>Algorithm</b>	<b>CAVP Cert</b>	<b>Properties</b>	<b>Reference</b>
AES-GCM	A5903	Direction - Decrypt, Encrypt IV Generation - External, Internal Key Length - 128, 192, 256 IV Generation Mode - 8.2.2	SP 800-38D
AES-GCM	A5904	Direction - Decrypt, Encrypt IV Generation - External, Internal Key Length - 128, 192, 256 IV Generation Mode - 8.2.2	SP 800-38D
AES-GCM	A5905	Direction - Decrypt, Encrypt IV Generation - External, Internal Key Length - 128, 192, 256 IV Generation Mode - 8.2.2	SP 800-38D
AES-GMAC	A5870	Direction - Decrypt, Encrypt IV Generation - External Key Length - 128, 192, 256	SP 800-38D
AES-GMAC	A5871	Direction - Decrypt, Encrypt IV Generation - External Key Length - 128, 192, 256	SP 800-38D
AES-GMAC	A5872	Direction - Decrypt, Encrypt IV Generation - External Key Length - 128, 192, 256	SP 800-38D
AES-GMAC	A5873	Direction - Decrypt, Encrypt IV Generation - External Key Length - 128, 192, 256	SP 800-38D
AES-GMAC	A5874	Direction - Decrypt, Encrypt IV Generation - External Key Length - 128, 192, 256	SP 800-38D
AES-GMAC	A5875	Direction - Decrypt, Encrypt IV Generation - External Key Length - 128, 192, 256	SP 800-38D
AES-GMAC	A5880	Direction - Decrypt, Encrypt IV Generation - External Key Length - 128, 192, 256	SP 800-38D
AES-GMAC	A5881	Direction - Decrypt, Encrypt IV Generation - External Key Length - 128, 192, 256	SP 800-38D

<b>Algorithm</b>	<b>CAVP Cert</b>	<b>Properties</b>	<b>Reference</b>
AES-GMAC	A5882	Direction - Decrypt, Encrypt IV Generation - External Key Length - 128, 192, 256	SP 800-38D
AES-GMAC	A5886	Direction - Decrypt, Encrypt IV Generation - External Key Length - 128, 192, 256	SP 800-38D
AES-GMAC	A5887	Direction - Decrypt, Encrypt IV Generation - External Key Length - 128, 192, 256	SP 800-38D
AES-GMAC	A5888	Direction - Decrypt, Encrypt IV Generation - External Key Length - 128, 192, 256	SP 800-38D
AES-GMAC	A5903	Direction - Decrypt, Encrypt IV Generation - External Key Length - 128, 192, 256	SP 800-38D
AES-GMAC	A5904	Direction - Decrypt, Encrypt IV Generation - External Key Length - 128, 192, 256	SP 800-38D
AES-GMAC	A5905	Direction - Decrypt, Encrypt IV Generation - External Key Length - 128, 192, 256	SP 800-38D
AES-KW	A5398	Direction - Decrypt, Encrypt Key Length - 128, 192, 256	SP 800-38F
AES-KW	A5399	Direction - Decrypt, Encrypt Key Length - 128, 192, 256	SP 800-38F
AES-KW	A5400	Direction - Decrypt, Encrypt Key Length - 128, 192, 256	SP 800-38F
AES-KW	A5401	Direction - Decrypt, Encrypt Key Length - 128, 192, 256	SP 800-38F
AES-KW	A5402	Direction - Decrypt, Encrypt Key Length - 128, 192, 256	SP 800-38F
AES-KW	A5403	Direction - Decrypt, Encrypt Key Length - 128, 192, 256	SP 800-38F
AES-KW	A5658	Direction - Decrypt, Encrypt Key Length - 128, 192, 256	SP 800-38F

<b>Algorithm</b>	<b>CAVP Cert</b>	<b>Properties</b>	<b>Reference</b>
AES-KWP	A5398	Direction - Decrypt, Encrypt Key Length - 128, 192, 256	SP 800-38F
AES-KWP	A5399	Direction - Decrypt, Encrypt Key Length - 128, 192, 256	SP 800-38F
AES-KWP	A5400	Direction - Decrypt, Encrypt Key Length - 128, 192, 256	SP 800-38F
AES-KWP	A5401	Direction - Decrypt, Encrypt Key Length - 128, 192, 256	SP 800-38F
AES-KWP	A5402	Direction - Decrypt, Encrypt Key Length - 128, 192, 256	SP 800-38F
AES-KWP	A5403	Direction - Decrypt, Encrypt Key Length - 128, 192, 256	SP 800-38F
AES-KWP	A5658	Direction - Decrypt, Encrypt Key Length - 128, 192, 256	SP 800-38F
AES-OFB	A5398	Direction - Decrypt, Encrypt Key Length - 128, 192, 256	SP 800-38A
AES-OFB	A5399	Direction - Decrypt, Encrypt Key Length - 128, 192, 256	SP 800-38A
AES-OFB	A5400	Direction - Decrypt, Encrypt Key Length - 128, 192, 256	SP 800-38A
AES-OFB	A5401	Direction - Decrypt, Encrypt Key Length - 128, 192, 256	SP 800-38A
AES-OFB	A5402	Direction - Decrypt, Encrypt Key Length - 128, 192, 256	SP 800-38A
AES-OFB	A5403	Direction - Decrypt, Encrypt Key Length - 128, 192, 256	SP 800-38A
AES-OFB	A5658	Direction - Decrypt, Encrypt Key Length - 128, 192, 256	SP 800-38A
AES-XTS Testing Revision 2.0	A5398	Direction - Decrypt, Encrypt Key Length - 128, 256	SP 800-38E
AES-XTS Testing Revision 2.0	A5399	Direction - Decrypt, Encrypt Key Length - 128, 256	SP 800-38E

© 2025 SUSE, LLC/atsec information security corporation.

This document can be reproduced and distributed only whole and intact, including this copyright notice.

<b>Algorithm</b>	<b>CAVP Cert</b>	<b>Properties</b>	<b>Reference</b>
AES-XTS Testing Revision 2.0	A5400	Direction - Decrypt, Encrypt Key Length - 128, 256	SP 800-38E
AES-XTS Testing Revision 2.0	A5401	Direction - Decrypt, Encrypt Key Length - 128, 256	SP 800-38E
AES-XTS Testing Revision 2.0	A5402	Direction - Decrypt, Encrypt Key Length - 128, 256	SP 800-38E
AES-XTS Testing Revision 2.0	A5403	Direction - Decrypt, Encrypt Key Length - 128, 256	SP 800-38E
AES-XTS Testing Revision 2.0	A5658	Direction - Decrypt, Encrypt Key Length - 128, 256	SP 800-38E
Counter DRBG	A5397	Prediction Resistance - No, Yes Capabilities - Mode - AES-128 Derivation Function Enabled - Yes	SP 800-90A Rev. 1
ECDSA KeyGen (FIPS186-5)	A5868	Curve - P-224, P-256, P-384, P-521 Secret Generation Mode - testing candidates	FIPS 186-5
ECDSA KeyGen (FIPS186-5)	A5876	Curve - P-224, P-256, P-384, P-521 Secret Generation Mode - testing candidates	FIPS 186-5
ECDSA KeyGen (FIPS186-5)	A5877	Curve - P-224, P-256, P-384, P-521 Secret Generation Mode - testing candidates	FIPS 186-5
ECDSA KeyGen (FIPS186-5)	A5878	Curve - P-224, P-256, P-384, P-521 Secret Generation Mode - testing candidates	FIPS 186-5
ECDSA KeyGen (FIPS186-5)	A5879	Curve - P-224, P-256, P-384, P-521 Secret Generation Mode - testing candidates	FIPS 186-5
ECDSA KeyGen (FIPS186-5)	A5883	Curve - P-224, P-256, P-384, P-521 Secret Generation Mode - testing candidates	FIPS 186-5

<b>Algorithm</b>	<b>CAVP Cert</b>	<b>Properties</b>	<b>Reference</b>
ECDSA KeyGen (FIPS186-5)	A5889	Curve - P-224, P-256, P-384, P-521 Secret Generation Mode - testing candidates	FIPS 186-5
ECDSA KeyVer (FIPS186-5)	A5868	Curve - P-224, P-256, P-384, P-521	FIPS 186-5
ECDSA KeyVer (FIPS186-5)	A5876	Curve - P-224, P-256, P-384, P-521	FIPS 186-5
ECDSA KeyVer (FIPS186-5)	A5877	Curve - P-224, P-256, P-384, P-521	FIPS 186-5
ECDSA KeyVer (FIPS186-5)	A5878	Curve - P-224, P-256, P-384, P-521	FIPS 186-5
ECDSA KeyVer (FIPS186-5)	A5879	Curve - P-224, P-256, P-384, P-521	FIPS 186-5
ECDSA KeyVer (FIPS186-5)	A5883	Curve - P-224, P-256, P-384, P-521	FIPS 186-5
ECDSA KeyVer (FIPS186-5)	A5889	Curve - P-224, P-256, P-384, P-521	FIPS 186-5
ECDSA SigGen (FIPS186-5)	A5868	Capabilities - Curve - P-224, P-256, P-384, P-521 Hash Algorithm - SHA2-224, SHA2-256, SHA2-384, SHA2-512, SHA2-512/224, SHA2-512/256 Component - No, Yes	FIPS 186-5
ECDSA SigGen (FIPS186-5)	A5869	Capabilities - Curve - P-224, P-256, P-384, P-521 Hash Algorithm - SHA3-224, SHA3-256, SHA3-384, SHA3-512 Component - No, Yes	FIPS 186-5
ECDSA SigGen (FIPS186-5)	A5876	Capabilities - Curve - P-224, P-256, P-384, P-521 Hash Algorithm - SHA2-224, SHA2-256, SHA2-384, SHA2-512, SHA2-512/224, SHA2-512/256 Component - No, Yes	FIPS 186-5

<b>Algorithm</b>	<b>CAVP Cert</b>	<b>Properties</b>	<b>Reference</b>
ECDSA SigGen (FIPS186-5)	A5877	Capabilities - Curve - P-224, P-256, P-384, P-521 Hash Algorithm - SHA2-224, SHA2-256, SHA2-384, SHA2-512, SHA2-512/224, SHA2-512/256 Component - No, Yes	FIPS 186-5
ECDSA SigGen (FIPS186-5)	A5878	Capabilities - Curve - P-224, P-256, P-384, P-521 Hash Algorithm - SHA2-224, SHA2-256, SHA2-384, SHA2-512, SHA2-512/224, SHA2-512/256 Component - No, Yes	FIPS 186-5
ECDSA SigGen (FIPS186-5)	A5879	Capabilities - Curve - P-224, P-256, P-384, P-521 Hash Algorithm - SHA2-224, SHA2-256, SHA2-384, SHA2-512, SHA2-512/224, SHA2-512/256 Component - No, Yes	FIPS 186-5
ECDSA SigGen (FIPS186-5)	A5883	Capabilities - Curve - P-224, P-256, P-384, P-521 Hash Algorithm - SHA2-224, SHA2-256, SHA2-384, SHA2-512, SHA2-512/224, SHA2-512/256 Component - No, Yes	FIPS 186-5
ECDSA SigGen (FIPS186-5)	A5885	Capabilities - Curve - P-224, P-256, P-384, P-521 Hash Algorithm - SHA3-224, SHA3-256, SHA3-384, SHA3-512 Component - No, Yes	FIPS 186-5
ECDSA SigGen (FIPS186-5)	A5889	Capabilities - Curve - P-224, P-256, P-384, P-521 Hash Algorithm - SHA2-224, SHA2-256, SHA2-384, SHA2-512, SHA2-512/224, SHA2-512/256 Component - No, Yes	FIPS 186-5
ECDSA SigVer (FIPS186-5)	A5868	Capabilities - Curve - P-224, P-256, P-384, P-521 Hash Algorithm - SHA2-224, SHA2-256, SHA2-384, SHA2-512, SHA2-512/224, SHA2-512/256	FIPS 186-5
ECDSA SigVer (FIPS186-5)	A5869	Capabilities - Curve - P-224, P-256, P-384, P-521 Hash Algorithm - SHA3-224, SHA3-256, SHA3-384, SHA3-512	FIPS 186-5
ECDSA SigVer (FIPS186-5)	A5876	Capabilities - Curve - P-224, P-256, P-384, P-521	FIPS 186-5

Algorithm	CAVP Cert	Properties	Reference
		Hash Algorithm - SHA2-224, SHA2-256, SHA2-384, SHA2-512, SHA2-512/224, SHA2-512/256	
ECDSA SigVer (FIPS186-5)	A5877	Capabilities - Curve - P-224, P-256, P-384, P-521 Hash Algorithm - SHA2-224, SHA2-256, SHA2-384, SHA2-512, SHA2-512/224, SHA2-512/256	FIPS 186-5
ECDSA SigVer (FIPS186-5)	A5878	Capabilities - Curve - P-224, P-256, P-384, P-521 Hash Algorithm - SHA2-224, SHA2-256, SHA2-384, SHA2-512, SHA2-512/224, SHA2-512/256	FIPS 186-5
ECDSA SigVer (FIPS186-5)	A5879	Capabilities - Curve - P-224, P-256, P-384, P-521 Hash Algorithm - SHA2-224, SHA2-256, SHA2-384, SHA2-512, SHA2-512/224, SHA2-512/256	FIPS 186-5
ECDSA SigVer (FIPS186-5)	A5883	Capabilities - Curve - P-224, P-256, P-384, P-521 Hash Algorithm - SHA2-224, SHA2-256, SHA2-384, SHA2-512, SHA2-512/224, SHA2-512/256	FIPS 186-5
ECDSA SigVer (FIPS186-5)	A5885	Capabilities - Curve - P-224, P-256, P-384, P-521 Hash Algorithm - SHA3-224, SHA3-256, SHA3-384, SHA3-512	FIPS 186-5
ECDSA SigVer (FIPS186-5)	A5889	Capabilities - Curve - P-224, P-256, P-384, P-521 Hash Algorithm - SHA2-224, SHA2-256, SHA2-384, SHA2-512, SHA2-512/224, SHA2-512/256	FIPS 186-5
Hash DRBG	A5397	Prediction Resistance - No, Yes Capabilities - Mode - SHA-1	SP 800-90A Rev. 1
HMAC DRBG	A5397	Prediction Resistance - No, Yes Capabilities - Mode - SHA-1	SP 800-90A Rev. 1
HMAC-SHA-1	A5868	Key Length - Key Length: 112-524288 Increment 8	FIPS 198-1
HMAC-SHA-1	A5876	Key Length - Key Length: 112-524288 Increment 8	FIPS 198-1
HMAC-SHA-1	A5877	Key Length - Key Length: 112-524288 Increment 8	FIPS 198-1

<b>Algorithm</b>	<b>CAVP Cert</b>	<b>Properties</b>	<b>Reference</b>
HMAC-SHA-1	A5878	Key Length - Key Length: 112-524288 Increment 8	FIPS 198-1
HMAC-SHA-1	A5879	Key Length - Key Length: 112-524288 Increment 8	FIPS 198-1
HMAC-SHA-1	A5883	Key Length - Key Length: 112-524288 Increment 8	FIPS 198-1
HMAC-SHA-1	A5889	Key Length - Key Length: 112-524288 Increment 8	FIPS 198-1
HMAC-SHA2-224	A5868	Key Length - Key Length: 112-524288 Increment 8	FIPS 198-1
HMAC-SHA2-224	A5876	Key Length - Key Length: 112-524288 Increment 8	FIPS 198-1
HMAC-SHA2-224	A5877	Key Length - Key Length: 112-524288 Increment 8	FIPS 198-1
HMAC-SHA2-224	A5878	Key Length - Key Length: 112-524288 Increment 8	FIPS 198-1
HMAC-SHA2-224	A5879	Key Length - Key Length: 112-524288 Increment 8	FIPS 198-1
HMAC-SHA2-224	A5883	Key Length - Key Length: 112-524288 Increment 8	FIPS 198-1
HMAC-SHA2-224	A5889	Key Length - Key Length: 112-524288 Increment 8	FIPS 198-1
HMAC-SHA2-256	A5864	Key Length - Key Length: 112-524288 Increment 8	FIPS 198-1
HMAC-SHA2-256	A5868	Key Length - Key Length: 112-524288 Increment 8	FIPS 198-1
HMAC-SHA2-256	A5876	Key Length - Key Length: 112-524288 Increment 8	FIPS 198-1
HMAC-SHA2-256	A5877	Key Length - Key Length: 112-524288 Increment 8	FIPS 198-1
HMAC-SHA2-256	A5878	Key Length - Key Length: 112-524288 Increment 8	FIPS 198-1

<b>Algorithm</b>	<b>CAVP Cert</b>	<b>Properties</b>	<b>Reference</b>
HMAC-SHA2-256	A5879	Key Length - Key Length: 112-524288 Increment 8	FIPS 198-1
HMAC-SHA2-256	A5883	Key Length - Key Length: 112-524288 Increment 8	FIPS 198-1
HMAC-SHA2-256	A5889	Key Length - Key Length: 112-524288 Increment 8	FIPS 198-1
HMAC-SHA2-384	A5868	Key Length - Key Length: 112-524288 Increment 8	FIPS 198-1
HMAC-SHA2-384	A5876	Key Length - Key Length: 112-524288 Increment 8	FIPS 198-1
HMAC-SHA2-384	A5877	Key Length - Key Length: 112-524288 Increment 8	FIPS 198-1
HMAC-SHA2-384	A5878	Key Length - Key Length: 112-524288 Increment 8	FIPS 198-1
HMAC-SHA2-384	A5879	Key Length - Key Length: 112-524288 Increment 8	FIPS 198-1
HMAC-SHA2-384	A5883	Key Length - Key Length: 112-524288 Increment 8	FIPS 198-1
HMAC-SHA2-384	A5889	Key Length - Key Length: 112-524288 Increment 8	FIPS 198-1
HMAC-SHA2-512	A5868	Key Length - Key Length: 112-524288 Increment 8	FIPS 198-1
HMAC-SHA2-512	A5876	Key Length - Key Length: 112-524288 Increment 8	FIPS 198-1
HMAC-SHA2-512	A5877	Key Length - Key Length: 112-524288 Increment 8	FIPS 198-1
HMAC-SHA2-512	A5878	Key Length - Key Length: 112-524288 Increment 8	FIPS 198-1
HMAC-SHA2-512	A5879	Key Length - Key Length: 112-524288 Increment 8	FIPS 198-1
HMAC-SHA2-512	A5883	Key Length - Key Length: 112-524288 Increment 8	FIPS 198-1

<b>Algorithm</b>	<b>CAVP Cert</b>	<b>Properties</b>	<b>Reference</b>
HMAC-SHA2-512	A5889	Key Length - Key Length: 112-524288 Increment 8	FIPS 198-1
HMAC-SHA2-512/224	A5868	Key Length - Key Length: 112-524288 Increment 8	FIPS 198-1
HMAC-SHA2-512/224	A5876	Key Length - Key Length: 112-524288 Increment 8	FIPS 198-1
HMAC-SHA2-512/224	A5877	Key Length - Key Length: 112-524288 Increment 8	FIPS 198-1
HMAC-SHA2-512/224	A5878	Key Length - Key Length: 112-524288 Increment 8	FIPS 198-1
HMAC-SHA2-512/224	A5879	Key Length - Key Length: 112-524288 Increment 8	FIPS 198-1
HMAC-SHA2-512/224	A5883	Key Length - Key Length: 112-524288 Increment 8	FIPS 198-1
HMAC-SHA2-512/224	A5889	Key Length - Key Length: 112-524288 Increment 8	FIPS 198-1
HMAC-SHA2-512/256	A5868	Key Length - Key Length: 112-524288 Increment 8	FIPS 198-1
HMAC-SHA2-512/256	A5876	Key Length - Key Length: 112-524288 Increment 8	FIPS 198-1
HMAC-SHA2-512/256	A5877	Key Length - Key Length: 112-524288 Increment 8	FIPS 198-1
HMAC-SHA2-512/256	A5878	Key Length - Key Length: 112-524288 Increment 8	FIPS 198-1
HMAC-SHA2-512/256	A5879	Key Length - Key Length: 112-524288 Increment 8	FIPS 198-1
HMAC-SHA2-512/256	A5883	Key Length - Key Length: 112-524288 Increment 8	FIPS 198-1
HMAC-SHA2-512/256	A5889	Key Length - Key Length: 112-524288 Increment 8	FIPS 198-1
HMAC-SHA3-224	A5869	Key Length - Key Length: 112-524288 Increment 8	FIPS 198-1

<b>Algorithm</b>	<b>CAVP Cert</b>	<b>Properties</b>	<b>Reference</b>
HMAC-SHA3-224	A5885	Key Length - Key Length: 112-524288 Increment 8	FIPS 198-1
HMAC-SHA3-256	A5869	Key Length - Key Length: 112-524288 Increment 8	FIPS 198-1
HMAC-SHA3-256	A5885	Key Length - Key Length: 112-524288 Increment 8	FIPS 198-1
HMAC-SHA3-384	A5869	Key Length - Key Length: 112-524288 Increment 8	FIPS 198-1
HMAC-SHA3-384	A5885	Key Length - Key Length: 112-524288 Increment 8	FIPS 198-1
HMAC-SHA3-512	A5869	Key Length - Key Length: 112-524288 Increment 8	FIPS 198-1
HMAC-SHA3-512	A5885	Key Length - Key Length: 112-524288 Increment 8	FIPS 198-1
KAS-ECC-SSC Sp800-56Ar3	A5868	Domain Parameter Generation Methods - P-224, P-256, P-384, P-521 Scheme - ephemeralUnified - KAS Role - initiator, responder	SP 800-56A Rev. 3
KAS-ECC-SSC Sp800-56Ar3	A5876	Domain Parameter Generation Methods - P-224, P-256, P-384, P-521 Scheme - ephemeralUnified - KAS Role - initiator, responder	SP 800-56A Rev. 3
KAS-ECC-SSC Sp800-56Ar3	A5877	Domain Parameter Generation Methods - P-224, P-256, P-384, P-521 Scheme - ephemeralUnified - KAS Role - initiator, responder	SP 800-56A Rev. 3
KAS-ECC-SSC Sp800-56Ar3	A5878	Domain Parameter Generation Methods - P-224, P-256, P-384, P-521 Scheme - ephemeralUnified - KAS Role - initiator, responder	SP 800-56A Rev. 3
KAS-ECC-SSC Sp800-56Ar3	A5879	Domain Parameter Generation Methods - P-224, P-256, P-384, P-521 Scheme -	SP 800-56A Rev. 3

Algorithm	CAVP Cert	Properties	Reference
		ephemeralUnified - KAS Role - initiator, responder	
KAS-ECC-SSC Sp800-56Ar3	A5883	Domain Parameter Generation Methods - P-224, P-256, P-384, P-521 Scheme - ephemeralUnified - KAS Role - initiator, responder	SP 800-56A Rev. 3
KAS-ECC-SSC Sp800-56Ar3	A5889	Domain Parameter Generation Methods - P-224, P-256, P-384, P-521 Scheme - ephemeralUnified - KAS Role - initiator, responder	SP 800-56A Rev. 3
KAS-FFC-SSC Sp800-56Ar3	A5898	Domain Parameter Generation Methods - ffdhe2048, ffdhe3072, ffdhe4096, ffdhe6144, ffdhe8192, MODP-2048, MODP-3072, MODP- 4096, MODP-6144, MODP-8192 Scheme - dhEphem - KAS Role - initiator, responder	SP 800-56A Rev. 3
KAS-IFC-SSC	A5868	Modulo - 2048, 3072, 4096, 6144, 8192 Key Generation Methods - rsakpg1-basic, rsakpg1-crt, rsakpg1-prime-factor, rsakpg2-basic, rsakpg2-crt, rsakpg2-prime-factor Scheme - KAS1 - KAS Role - initiator, responder KAS2 - KAS Role - initiator, responder	SP 800-56A Rev. 3
KAS-IFC-SSC	A5876	Modulo - 2048, 3072, 4096, 6144, 8192 Key Generation Methods - rsakpg1-basic, rsakpg1-crt, rsakpg1-prime-factor, rsakpg2-basic, rsakpg2-crt, rsakpg2-prime-factor Scheme - KAS1 - KAS Role - initiator, responder KAS2 - KAS Role - initiator, responder	SP 800-56A Rev. 3
KAS-IFC-SSC	A5877	Modulo - 2048, 3072, 4096, 6144, 8192 Key Generation Methods - rsakpg1-basic, rsakpg1-crt, rsakpg1-prime-factor, rsakpg2-basic, rsakpg2-crt, rsakpg2-prime-factor Scheme - KAS1 - KAS Role - initiator, responder	SP 800-56A Rev. 3

Algorithm	CAVP Cert	Properties	Reference
		KAS2 - KAS Role - initiator, responder	
KAS-IFC-SSC	A5878	Modulo - 2048, 3072, 4096, 6144, 8192 Key Generation Methods - rsakpg1-basic, rsakpg1-crt, rsakpg1-prime-factor, rsakpg2-basic, rsakpg2-crt, rsakpg2-prime-factor Scheme - KAS1 - KAS Role - initiator, responder KAS2 - KAS Role - initiator, responder	SP 800-56A Rev. 3
KAS-IFC-SSC	A5879	Modulo - 2048, 3072, 4096, 6144, 8192 Key Generation Methods - rsakpg1-basic, rsakpg1-crt, rsakpg1-prime-factor, rsakpg2-basic, rsakpg2-crt, rsakpg2-prime-factor Scheme - KAS1 - KAS Role - initiator, responder KAS2 - KAS Role - initiator, responder	SP 800-56A Rev. 3
KAS-IFC-SSC	A5883	Modulo - 2048, 3072, 4096, 6144, 8192 Key Generation Methods - rsakpg1-basic, rsakpg1-crt, rsakpg1-prime-factor, rsakpg2-basic, rsakpg2-crt, rsakpg2-prime-factor Scheme - KAS1 - KAS Role - initiator, responder KAS2 - KAS Role - initiator, responder	SP 800-56A Rev. 3
KAS-IFC-SSC	A5889	Modulo - 2048, 3072, 4096, 6144, 8192 Key Generation Methods - rsakpg1-basic, rsakpg1-crt, rsakpg1-prime-factor, rsakpg2-basic, rsakpg2-crt, rsakpg2-prime-factor Scheme - KAS1 - KAS Role - initiator, responder KAS2 - KAS Role - initiator, responder	SP 800-56A Rev. 3
KDA HKDF SP800-56Cr2	A5863	Derived Key Length - 2048 Shared Secret Length - Shared Secret Length: 224-8192 Increment 8 HMAC Algorithm - SHA-1, SHA2-224, SHA2-256, SHA2-384, SHA2-512, SHA2-512/224, SHA2- 512/256, SHA3-224, SHA3-256, SHA3-384, SHA3- 512	SP 800-56C Rev. 2

<b>Algorithm</b>	<b>CAVP Cert</b>	<b>Properties</b>	<b>Reference</b>
KDA OneStep SP800-56Cr2	A5897	Derived Key Length - 2048 Shared Secret Length - Shared Secret Length: 224-2048 Increment 8	SP 800-56C Rev. 2
KDA TwoStep SP800-56Cr2	A5897	Capabilities - MAC Salting Methods - default, random KDF Mode - feedback Derived Key Length - 2048 Shared Secret Length - Shared Secret Length: 224-2048 Increment 8	SP 800-56C Rev. 2
KDF ANS 9.42 (CVL)	A5868	KDF Type - DER Hash Algorithm - SHA-1, SHA2-224, SHA2-256, SHA2-384, SHA2-512, SHA2-512/224, SHA2- 512/256 Key Data Length - Key Data Length: 112-4096 Increment 8	SP 800-135 Rev. 1
KDF ANS 9.42 (CVL)	A5869	KDF Type - DER Hash Algorithm - SHA3-224, SHA3-256, SHA3- 384, SHA3-512 Key Data Length - Key Data Length: 112-4096 Increment 8	SP 800-135 Rev. 1
KDF ANS 9.42 (CVL)	A5876	KDF Type - DER Hash Algorithm - SHA-1, SHA2-224, SHA2-256, SHA2-384, SHA2-512, SHA2-512/224, SHA2- 512/256 Key Data Length - Key Data Length: 112-4096 Increment 8	SP 800-135 Rev. 1
KDF ANS 9.42 (CVL)	A5877	KDF Type - DER Hash Algorithm - SHA-1, SHA2-224, SHA2-256, SHA2-384, SHA2-512, SHA2-512/224, SHA2- 512/256 Key Data Length - Key Data Length: 112-4096 Increment 8	SP 800-135 Rev. 1
KDF ANS 9.42 (CVL)	A5878	KDF Type - DER Hash Algorithm - SHA-1, SHA2-224, SHA2-256, SHA2-384, SHA2-512, SHA2-512/224, SHA2- 512/256 Key Data Length - Key Data Length: 112-4096 Increment 8	SP 800-135 Rev. 1
KDF ANS 9.42 (CVL)	A5879	KDF Type - DER Hash Algorithm - SHA-1, SHA2-224, SHA2-256, SHA2-384, SHA2-512, SHA2-512/224, SHA2- 512/256	SP 800-135 Rev. 1

<b>Algorithm</b>	<b>CAVP Cert</b>	<b>Properties</b>	<b>Reference</b>
		Key Data Length - Key Data Length: 112-4096 Increment 8	
KDF ANS 9.42 (CVL)	A5883	KDF Type - DER Hash Algorithm - SHA-1, SHA2-224, SHA2-256, SHA2-384, SHA2-512, SHA2-512/224, SHA2- 512/256 Key Data Length - Key Data Length: 112-4096 Increment 8	SP 800-135 Rev. 1
KDF ANS 9.42 (CVL)	A5885	KDF Type - DER Hash Algorithm - SHA3-224, SHA3-256, SHA3- 384, SHA3-512 Key Data Length - Key Data Length: 112-4096 Increment 8	SP 800-135 Rev. 1
KDF ANS 9.42 (CVL)	A5889	KDF Type - DER Hash Algorithm - SHA-1, SHA2-224, SHA2-256, SHA2-384, SHA2-512, SHA2-512/224, SHA2- 512/256 Key Data Length - Key Data Length: 112-4096 Increment 8	SP 800-135 Rev. 1
KDF ANS 9.63 (CVL)	A5868	Hash Algorithm - SHA2-224, SHA2-256, SHA2- 384, SHA2-512, SHA2-512/224, SHA2-512/256 Key Data Length - Key Data Length: 128-4096 Increment 8	SP 800-135 Rev. 1
KDF ANS 9.63 (CVL)	A5869	Hash Algorithm - SHA3-224, SHA3-256, SHA3- 384, SHA3-512 Key Data Length - Key Data Length: 128-4096 Increment 8	SP 800-135 Rev. 1
KDF ANS 9.63 (CVL)	A5876	Hash Algorithm - SHA2-224, SHA2-256, SHA2- 384, SHA2-512, SHA2-512/224, SHA2-512/256 Key Data Length - Key Data Length: 128-4096 Increment 8	SP 800-135 Rev. 1
KDF ANS 9.63 (CVL)	A5877	Hash Algorithm - SHA2-224, SHA2-256, SHA2- 384, SHA2-512, SHA2-512/224, SHA2-512/256 Key Data Length - Key Data Length: 128-4096 Increment 8	SP 800-135 Rev. 1
KDF ANS 9.63 (CVL)	A5878	Hash Algorithm - SHA2-224, SHA2-256, SHA2- 384, SHA2-512, SHA2-512/224, SHA2-512/256 Key Data Length - Key Data Length: 128-4096 Increment 8	SP 800-135 Rev. 1

<b>Algorithm</b>	<b>CAVP Cert</b>	<b>Properties</b>	<b>Reference</b>
KDF ANS 9.63 (CVL)	A5879	Hash Algorithm - SHA2-224, SHA2-256, SHA2-384, SHA2-512, SHA2-512/224, SHA2-512/256 Key Data Length - Key Data Length: 128-4096 Increment 8	SP 800-135 Rev. 1
KDF ANS 9.63 (CVL)	A5883	Hash Algorithm - SHA2-224, SHA2-256, SHA2-384, SHA2-512, SHA2-512/224, SHA2-512/256 Key Data Length - Key Data Length: 128-4096 Increment 8	SP 800-135 Rev. 1
KDF ANS 9.63 (CVL)	A5885	Hash Algorithm - SHA3-224, SHA3-256, SHA3-384, SHA3-512 Key Data Length - Key Data Length: 128-4096 Increment 8	SP 800-135 Rev. 1
KDF ANS 9.63 (CVL)	A5889	Hash Algorithm - SHA2-224, SHA2-256, SHA2-384, SHA2-512, SHA2-512/224, SHA2-512/256 Key Data Length - Key Data Length: 128-4096 Increment 8	SP 800-135 Rev. 1
KDF SP800-108	A5899	Capabilities - KDF Mode - Counter Supported Lengths - Supported Lengths: 112-4096 Increment 8	SP 800-108 Rev. 1
KDF SSH (CVL)	A5884	Cipher - AES-128, AES-192, AES-256 Hash Algorithm - SHA-1, SHA2-224, SHA2-256, SHA2-384, SHA2-512	SP 800-135 Rev. 1
KDF SSH (CVL)	A5893	Cipher - AES-128, AES-192, AES-256 Hash Algorithm - SHA-1, SHA2-224, SHA2-256, SHA2-384, SHA2-512	SP 800-135 Rev. 1
KDF SSH (CVL)	A5894	Cipher - AES-128, AES-192, AES-256 Hash Algorithm - SHA-1, SHA2-224, SHA2-256, SHA2-384, SHA2-512	SP 800-135 Rev. 1
KDF SSH (CVL)	A5895	Cipher - AES-128, AES-192, AES-256 Hash Algorithm - SHA-1, SHA2-224, SHA2-256, SHA2-384, SHA2-512	SP 800-135 Rev. 1
KDF SSH (CVL)	A5896	Cipher - AES-128, AES-192, AES-256 Hash Algorithm - SHA-1, SHA2-224, SHA2-256, SHA2-384, SHA2-512	SP 800-135 Rev. 1
KDF SSH (CVL)	A5900	Cipher - AES-128, AES-192, AES-256 Hash Algorithm - SHA-1, SHA2-224, SHA2-256, SHA2-384, SHA2-512	SP 800-135 Rev. 1

<b>Algorithm</b>	<b>CAVP Cert</b>	<b>Properties</b>	<b>Reference</b>
KTS-IFC	A5868	Modulo - 2048, 3072, 4096, 6144, 8192 Key Generation Methods - rsakpg1-basic, rsakpg1-crt, rsakpg1-prime-factor, rsakpg2-basic, rsakpg2-crt, rsakpg2-prime-factor Scheme - KTS-OAEP-basic - KAS Role - initiator, responder Key Transport Method - Key Length - 768	SP 800-56B Rev. 2
KTS-IFC	A5876	Modulo - 2048, 3072, 4096, 6144, 8192 Key Generation Methods - rsakpg1-basic, rsakpg1-crt, rsakpg1-prime-factor, rsakpg2-basic, rsakpg2-crt, rsakpg2-prime-factor Scheme - KTS-OAEP-basic - KAS Role - initiator, responder Key Transport Method - Key Length - 768	SP 800-56B Rev. 2
KTS-IFC	A5877	Modulo - 2048, 3072, 4096, 6144, 8192 Key Generation Methods - rsakpg1-basic, rsakpg1-crt, rsakpg1-prime-factor, rsakpg2-basic, rsakpg2-crt, rsakpg2-prime-factor Scheme - KTS-OAEP-basic - KAS Role - initiator, responder Key Transport Method - Key Length - 768	SP 800-56B Rev. 2
KTS-IFC	A5878	Modulo - 2048, 3072, 4096, 6144, 8192 Key Generation Methods - rsakpg1-basic, rsakpg1-crt, rsakpg1-prime-factor, rsakpg2-basic, rsakpg2-crt, rsakpg2-prime-factor Scheme - KTS-OAEP-basic - KAS Role - initiator, responder Key Transport Method - Key Length - 768	SP 800-56B Rev. 2
KTS-IFC	A5879	Modulo - 2048, 3072, 4096, 6144, 8192 Key Generation Methods - rsakpg1-basic, rsakpg1-crt, rsakpg1-prime-factor, rsakpg2-basic, rsakpg2-crt, rsakpg2-prime-factor Scheme - KTS-OAEP-basic - KAS Role - initiator, responder Key Transport Method - Key Length - 768	SP 800-56B Rev. 2

<b>Algorithm</b>	<b>CAVP Cert</b>	<b>Properties</b>	<b>Reference</b>
KTS-IFC	A5883	Modulo - 2048, 3072, 4096, 6144, 8192 Key Generation Methods - rsakpg1-basic, rsakpg1-crt, rsakpg1-prime-factor, rsakpg2-basic, rsakpg2-crt, rsakpg2-prime-factor Scheme - KTS-OAEP-basic - KAS Role - initiator, responder Key Transport Method - Key Length - 768	SP 800-56B Rev. 2
KTS-IFC	A5889	Modulo - 2048, 3072, 4096, 6144, 8192 Key Generation Methods - rsakpg1-basic, rsakpg1-crt, rsakpg1-prime-factor, rsakpg2-basic, rsakpg2-crt, rsakpg2-prime-factor Scheme - KTS-OAEP-basic - KAS Role - initiator, responder Key Transport Method - Key Length - 768	SP 800-56B Rev. 2
PBKDF	A5868	Capabilities - Iteration Count - Iteration Count: 1000-10000 Increment 1 Password Length - Password Length: 8-128 Increment 1	SP 800-132
PBKDF	A5869	Capabilities - Iteration Count - Iteration Count: 1000-10000 Increment 1 Password Length - Password Length: 8-128 Increment 1	SP 800-132
PBKDF	A5876	Capabilities - Iteration Count - Iteration Count: 1000-10000 Increment 1 Password Length - Password Length: 8-128 Increment 1	SP 800-132
PBKDF	A5877	Capabilities - Iteration Count - Iteration Count: 1000-10000 Increment 1 Password Length - Password Length: 8-128 Increment 1	SP 800-132
PBKDF	A5878	Capabilities - Iteration Count - Iteration Count: 1000-10000 Increment 1 Password Length - Password Length: 8-128 Increment 1	SP 800-132

<b>Algorithm</b>	<b>CAVP Cert</b>	<b>Properties</b>	<b>Reference</b>
PBKDF	A5879	Capabilities - Iteration Count - Iteration Count: 1000-10000 Increment 1 Password Length - Password Length: 8-128 Increment 1	SP 800-132
PBKDF	A5883	Capabilities - Iteration Count - Iteration Count: 1000-10000 Increment 1 Password Length - Password Length: 8-128 Increment 1	SP 800-132
PBKDF	A5885	Capabilities - Iteration Count - Iteration Count: 1000-10000 Increment 1 Password Length - Password Length: 8-128 Increment 1	SP 800-132
PBKDF	A5889	Capabilities - Iteration Count - Iteration Count: 1000-10000 Increment 1 Password Length - Password Length: 8-128 Increment 1	SP 800-132
RSA KeyGen (FIPS186-5)	A5868	Capabilities - Key Generation Mode - probableWithProbableAux Properties - Modulo - 2048 Primality Tests - 2powSecStr Private Key Format - standard	FIPS 186-5
RSA KeyGen (FIPS186-5)	A5876	Capabilities - Key Generation Mode - probableWithProbableAux Properties - Modulo - 2048 Primality Tests - 2powSecStr Private Key Format - standard	FIPS 186-5
RSA KeyGen (FIPS186-5)	A5877	Capabilities - Key Generation Mode - probableWithProbableAux Properties - Modulo - 2048 Primality Tests - 2powSecStr Private Key Format - standard	FIPS 186-5
RSA KeyGen (FIPS186-5)	A5878	Capabilities - Key Generation Mode - probableWithProbableAux Properties - Modulo - 2048	FIPS 186-5

<b>Algorithm</b>	<b>CAVP Cert</b>	<b>Properties</b>	<b>Reference</b>
		Primality Tests - 2powSecStr Private Key Format - standard	
RSA KeyGen (FIPS186-5)	A5879	Capabilities - Key Generation Mode - probableWithProbableAux Properties - Modulo - 2048 Primality Tests - 2powSecStr Private Key Format - standard	FIPS 186-5
RSA KeyGen (FIPS186-5)	A5883	Capabilities - Key Generation Mode - probableWithProbableAux Properties - Modulo - 2048 Primality Tests - 2powSecStr Private Key Format - standard	FIPS 186-5
RSA KeyGen (FIPS186-5)	A5889	Capabilities - Key Generation Mode - probableWithProbableAux Properties - Modulo - 2048 Primality Tests - 2powSecStr Private Key Format - standard	FIPS 186-5
RSA SigGen (FIPS186-5)	A5868	Capabilities - Properties - Modulo - 2048 Signature Type - pkcs1v1.5	FIPS 186-5
RSA SigGen (FIPS186-5)	A5869	Capabilities - Properties - Modulo - 2048 Signature Type - pkcs1v1.5	FIPS 186-5
RSA SigGen (FIPS186-5)	A5876	Capabilities - Properties - Modulo - 2048 Signature Type - pkcs1v1.5	FIPS 186-5
RSA SigGen (FIPS186-5)	A5877	Capabilities - Properties - Modulo - 2048 Signature Type - pkcs1v1.5	FIPS 186-5
RSA SigGen (FIPS186-5)	A5878	Capabilities - Properties - Modulo - 2048 Signature Type - pkcs1v1.5	FIPS 186-5

<b>Algorithm</b>	<b>CAVP Cert</b>	<b>Properties</b>	<b>Reference</b>
RSA SigGen (FIPS186-5)	A5879	Capabilities - Properties - Modulo - 2048 Signature Type - pkcs1v1.5	FIPS 186-5
RSA SigGen (FIPS186-5)	A5883	Capabilities - Properties - Modulo - 2048 Signature Type - pkcs1v1.5	FIPS 186-5
RSA SigGen (FIPS186-5)	A5885	Capabilities - Properties - Modulo - 2048 Signature Type - pkcs1v1.5	FIPS 186-5
RSA SigGen (FIPS186-5)	A5889	Capabilities - Properties - Modulo - 2048 Signature Type - pkcs1v1.5	FIPS 186-5
RSA SigVer (FIPS186-2)	A5868	Capabilities - Signature Type - PKCSPSS Properties - Modulo - 1536	FIPS 186-4
RSA SigVer (FIPS186-2)	A5876	Capabilities - Signature Type - PKCS 1.5 Properties - Modulo - 1536	FIPS 186-4
RSA SigVer (FIPS186-2)	A5877	Capabilities - Signature Type - PKCS 1.5 Properties - Modulo - 1536	FIPS 186-4
RSA SigVer (FIPS186-2)	A5878	Capabilities - Signature Type - PKCS 1.5 Properties - Modulo - 1536	FIPS 186-4
RSA SigVer (FIPS186-2)	A5879	Capabilities - Signature Type - PKCS 1.5 Properties - Modulo - 1536	FIPS 186-4
RSA SigVer (FIPS186-2)	A5883	Capabilities - Signature Type - PKCS 1.5 Properties - Modulo - 1536	FIPS 186-4

© 2025 SUSE, LLC/atsec information security corporation.

This document can be reproduced and distributed only whole and intact, including this copyright notice.

<b>Algorithm</b>	<b>CAVP Cert</b>	<b>Properties</b>	<b>Reference</b>
RSA SigVer (FIPS186-2)	A5889	Capabilities - Signature Type - PKCS 1.5 Properties - Modulo - 1536	FIPS 186-4
RSA SigVer (FIPS186-4)	A5868	Capabilities - Signature Type - PKCS 1.5 Properties - Modulo - 1024	FIPS 186-4
RSA SigVer (FIPS186-4)	A5876	Capabilities - Signature Type - PKCS 1.5 Properties - Modulo - 1024	FIPS 186-4
RSA SigVer (FIPS186-4)	A5877	Capabilities - Signature Type - PKCS 1.5 Properties - Modulo - 1024	FIPS 186-4
RSA SigVer (FIPS186-4)	A5878	Capabilities - Signature Type - PKCS 1.5 Properties - Modulo - 1024	FIPS 186-4
RSA SigVer (FIPS186-4)	A5879	Capabilities - Signature Type - PKCS 1.5 Properties - Modulo - 1024	FIPS 186-4
RSA SigVer (FIPS186-4)	A5883	Capabilities - Signature Type - PKCS 1.5 Properties - Modulo - 1024	FIPS 186-4
RSA SigVer (FIPS186-4)	A5889	Capabilities - Signature Type - PKCS 1.5 Properties - Modulo - 1024	FIPS 186-4
RSA SigVer (FIPS186-5)	A5868	Capabilities - Properties - Modulo - 2048 Signature Type - pkcs1v1.5	FIPS 186-5
RSA SigVer (FIPS186-5)	A5869	Capabilities - Properties - Modulo - 2048 Signature Type - pkcs1v1.5	FIPS 186-5

<b>Algorithm</b>	<b>CAVP Cert</b>	<b>Properties</b>	<b>Reference</b>
RSA SigVer (FIPS186-5)	A5876	Capabilities - Properties - Modulo - 2048 Signature Type - pkcs1v1.5	FIPS 186-5
RSA SigVer (FIPS186-5)	A5877	Capabilities - Properties - Modulo - 2048 Signature Type - pkcs1v1.5	FIPS 186-5
RSA SigVer (FIPS186-5)	A5878	Capabilities - Properties - Modulo - 2048 Signature Type - pkcs1v1.5	FIPS 186-5
RSA SigVer (FIPS186-5)	A5879	Capabilities - Properties - Modulo - 2048 Signature Type - pkcs1v1.5	FIPS 186-5
RSA SigVer (FIPS186-5)	A5883	Capabilities - Properties - Modulo - 2048 Signature Type - pkcs1v1.5	FIPS 186-5
RSA SigVer (FIPS186-5)	A5885	Capabilities - Properties - Modulo - 2048 Signature Type - pkcs1v1.5	FIPS 186-5
RSA SigVer (FIPS186-5)	A5889	Capabilities - Properties - Modulo - 2048 Signature Type - pkcs1v1.5	FIPS 186-5
Safe Primes Key Generation	A5898	Safe Prime Groups - ffdhe2048, ffdhe3072, ffdhe4096, ffdhe6144, ffdhe8192, MODP-2048, MODP-3072, MODP-4096, MODP-6144, MODP-8192	SP 800-56A Rev. 3
Safe Primes Key Verification	A5898	Safe Prime Groups - ffdhe2048, ffdhe3072, ffdhe4096, ffdhe6144, ffdhe8192, MODP-2048, MODP-3072, MODP-4096, MODP-6144, MODP-8192	SP 800-56A Rev. 3
SHA-1	A5868	Message Length - Message Length: 0-65536 Increment 8 Large Message Sizes - 1, 2, 4, 8	FIPS 180-4

<b>Algorithm</b>	<b>CAVP Cert</b>	<b>Properties</b>	<b>Reference</b>
SHA-1	A5876	Message Length - Message Length: 0-65536 Increment 8 Large Message Sizes - 1, 2, 4, 8	FIPS 180-4
SHA-1	A5877	Message Length - Message Length: 0-65536 Increment 8 Large Message Sizes - 1, 2, 4, 8	FIPS 180-4
SHA-1	A5878	Message Length - Message Length: 0-65536 Increment 8 Large Message Sizes - 1, 2, 4, 8	FIPS 180-4
SHA-1	A5879	Message Length - Message Length: 0-65536 Increment 8 Large Message Sizes - 1, 2, 4, 8	FIPS 180-4
SHA-1	A5883	Message Length - Message Length: 0-65536 Increment 8 Large Message Sizes - 1, 2, 4, 8	FIPS 180-4
SHA-1	A5889	Message Length - Message Length: 0-65536 Increment 8 Large Message Sizes - 1, 2, 4, 8	FIPS 180-4
SHA2-224	A5868	Message Length - Message Length: 0-65536 Increment 8 Large Message Sizes - 1, 2, 4, 8	FIPS 180-4
SHA2-224	A5876	Message Length - Message Length: 0-65536 Increment 8 Large Message Sizes - 1, 2, 4, 8	FIPS 180-4
SHA2-224	A5877	Message Length - Message Length: 0-65536 Increment 8 Large Message Sizes - 1, 2, 4, 8	FIPS 180-4
SHA2-224	A5878	Message Length - Message Length: 0-65536 Increment 8 Large Message Sizes - 1, 2, 4, 8	FIPS 180-4
SHA2-224	A5879	Message Length - Message Length: 0-65536 Increment 8 Large Message Sizes - 1, 2, 4, 8	FIPS 180-4
SHA2-224	A5883	Message Length - Message Length: 0-65536 Increment 8 Large Message Sizes - 1, 2, 4, 8	FIPS 180-4

<b>Algorithm</b>	<b>CAVP Cert</b>	<b>Properties</b>	<b>Reference</b>
SHA2-224	A5889	Message Length - Message Length: 0-65536 Increment 8 Large Message Sizes - 1, 2, 4, 8	FIPS 180-4
SHA2-256	A5864	Message Length - Message Length: 0-65536 Increment 8 Large Message Sizes - 1, 2, 4, 8	FIPS 180-4
SHA2-256	A5868	Message Length - Message Length: 0-65536 Increment 8 Large Message Sizes - 1, 2, 4, 8	FIPS 180-4
SHA2-256	A5876	Message Length - Message Length: 0-65536 Increment 8 Large Message Sizes - 1, 2, 4, 8	FIPS 180-4
SHA2-256	A5877	Message Length - Message Length: 0-65536 Increment 8 Large Message Sizes - 1, 2, 4, 8	FIPS 180-4
SHA2-256	A5878	Message Length - Message Length: 0-65536 Increment 8 Large Message Sizes - 1, 2, 4, 8	FIPS 180-4
SHA2-256	A5879	Message Length - Message Length: 0-65536 Increment 8 Large Message Sizes - 1, 2, 4, 8	FIPS 180-4
SHA2-256	A5883	Message Length - Message Length: 0-65536 Increment 8 Large Message Sizes - 1, 2, 4, 8	FIPS 180-4
SHA2-256	A5889	Message Length - Message Length: 0-65536 Increment 8 Large Message Sizes - 1, 2, 4, 8	FIPS 180-4
SHA2-384	A5868	Message Length - Message Length: 0-65536 Increment 8 Large Message Sizes - 1, 2, 4, 8	FIPS 180-4
SHA2-384	A5876	Message Length - Message Length: 0-65536 Increment 8 Large Message Sizes - 1, 2, 4, 8	FIPS 180-4
SHA2-384	A5877	Message Length - Message Length: 0-65536 Increment 8 Large Message Sizes - 1, 2, 4, 8	FIPS 180-4

<b>Algorithm</b>	<b>CAVP Cert</b>	<b>Properties</b>	<b>Reference</b>
SHA2-384	A5878	Message Length - Message Length: 0-65536 Increment 8 Large Message Sizes - 1, 2, 4, 8	FIPS 180-4
SHA2-384	A5879	Message Length - Message Length: 0-65536 Increment 8 Large Message Sizes - 1, 2, 4, 8	FIPS 180-4
SHA2-384	A5883	Message Length - Message Length: 0-65536 Increment 8 Large Message Sizes - 1, 2, 4, 8	FIPS 180-4
SHA2-384	A5889	Message Length - Message Length: 0-65536 Increment 8 Large Message Sizes - 1, 2, 4, 8	FIPS 180-4
SHA2-512	A5868	Message Length - Message Length: 0-65536 Increment 8 Large Message Sizes - 1, 2, 4, 8	FIPS 180-4
SHA2-512	A5876	Message Length - Message Length: 0-65536 Increment 8 Large Message Sizes - 1, 2, 4, 8	FIPS 180-4
SHA2-512	A5877	Message Length - Message Length: 0-65536 Increment 8 Large Message Sizes - 1, 2, 4, 8	FIPS 180-4
SHA2-512	A5878	Message Length - Message Length: 0-65536 Increment 8 Large Message Sizes - 1, 2, 4, 8	FIPS 180-4
SHA2-512	A5879	Message Length - Message Length: 0-65536 Increment 8 Large Message Sizes - 1, 2, 4, 8	FIPS 180-4
SHA2-512	A5883	Message Length - Message Length: 0-65536 Increment 8 Large Message Sizes - 1, 2, 4, 8	FIPS 180-4
SHA2-512	A5889	Message Length - Message Length: 0-65536 Increment 8 Large Message Sizes - 1, 2, 4, 8	FIPS 180-4
SHA2-512/224	A5868	Message Length - Message Length: 0-65536 Increment 8 Large Message Sizes - 1, 2, 4, 8	FIPS 180-4

<b>Algorithm</b>	<b>CAVP Cert</b>	<b>Properties</b>	<b>Reference</b>
SHA2-512/224	A5876	Message Length - Message Length: 0-65536 Increment 8 Large Message Sizes - 1, 2, 4, 8	FIPS 180-4
SHA2-512/224	A5877	Message Length - Message Length: 0-65536 Increment 8 Large Message Sizes - 1, 2, 4, 8	FIPS 180-4
SHA2-512/224	A5878	Message Length - Message Length: 0-65536 Increment 8 Large Message Sizes - 1, 2, 4, 8	FIPS 180-4
SHA2-512/224	A5879	Message Length - Message Length: 0-65536 Increment 8 Large Message Sizes - 1, 2, 4, 8	FIPS 180-4
SHA2-512/224	A5883	Message Length - Message Length: 0-65536 Increment 8 Large Message Sizes - 1, 2, 4, 8	FIPS 180-4
SHA2-512/224	A5889	Message Length - Message Length: 0-65536 Increment 8 Large Message Sizes - 1, 2, 4, 8	FIPS 180-4
SHA2-512/256	A5868	Message Length - Message Length: 0-65536 Increment 8 Large Message Sizes - 1, 2, 4, 8	FIPS 180-4
SHA2-512/256	A5876	Message Length - Message Length: 0-65536 Increment 8 Large Message Sizes - 1, 2, 4, 8	FIPS 180-4
SHA2-512/256	A5877	Message Length - Message Length: 0-65536 Increment 8 Large Message Sizes - 1, 2, 4, 8	FIPS 180-4
SHA2-512/256	A5878	Message Length - Message Length: 0-65536 Increment 8 Large Message Sizes - 1, 2, 4, 8	FIPS 180-4
SHA2-512/256	A5879	Message Length - Message Length: 0-65536 Increment 8 Large Message Sizes - 1, 2, 4, 8	FIPS 180-4
SHA2-512/256	A5883	Message Length - Message Length: 0-65536 Increment 8 Large Message Sizes - 1, 2, 4, 8	FIPS 180-4

<b>Algorithm</b>	<b>CAVP Cert</b>	<b>Properties</b>	<b>Reference</b>
SHA2-512/256	A5889	Message Length - Message Length: 0-65536 Increment 8 Large Message Sizes - 1, 2, 4, 8	FIPS 180-4
SHA3-224	A5869	Message Length - Message Length: 0-65536 Increment 8 Large Message Sizes - 1, 2, 4, 8	FIPS 202
SHA3-224	A5885	Message Length - Message Length: 0-65536 Increment 8 Large Message Sizes - 1, 2, 4, 8	FIPS 202
SHA3-256	A5869	Message Length - Message Length: 0-65536 Increment 8 Large Message Sizes - 1, 2, 4, 8	FIPS 202
SHA3-256	A5885	Message Length - Message Length: 0-65536 Increment 8 Large Message Sizes - 1, 2, 4, 8	FIPS 202
SHA3-384	A5869	Message Length - Message Length: 0-65536 Increment 8 Large Message Sizes - 1, 2, 4, 8	FIPS 202
SHA3-384	A5885	Message Length - Message Length: 0-65536 Increment 8 Large Message Sizes - 1, 2, 4, 8	FIPS 202
SHA3-512	A5869	Message Length - Message Length: 0-65536 Increment 8 Large Message Sizes - 1, 2, 4, 8	FIPS 202
SHA3-512	A5885	Message Length - Message Length: 0-65536 Increment 8 Large Message Sizes - 1, 2, 4, 8	FIPS 202
SHAKE-128	A5869	Output Length - Output Length: 16-65536 Increment 8	FIPS 202
SHAKE-128	A5885	Output Length - Output Length: 16-65536 Increment 8	FIPS 202
SHAKE-256	A5869	Output Length - Output Length: 16-65536 Increment 8	FIPS 202
SHAKE-256	A5885	Output Length - Output Length: 16-65536 Increment 8	FIPS 202

Algorithm	CAVP Cert	Properties	Reference
TLS v1.2 KDF RFC7627 (CVL)	A5868	Hash Algorithm - SHA2-256, SHA2-384, SHA2-512	SP 800-135 Rev. 1
TLS v1.2 KDF RFC7627 (CVL)	A5876	Hash Algorithm - SHA2-256, SHA2-384, SHA2-512	SP 800-135 Rev. 1
TLS v1.2 KDF RFC7627 (CVL)	A5877	Hash Algorithm - SHA2-256, SHA2-384, SHA2-512	SP 800-135 Rev. 1
TLS v1.2 KDF RFC7627 (CVL)	A5878	Hash Algorithm - SHA2-256, SHA2-384, SHA2-512	SP 800-135 Rev. 1
TLS v1.2 KDF RFC7627 (CVL)	A5879	Hash Algorithm - SHA2-256, SHA2-384, SHA2-512	SP 800-135 Rev. 1
TLS v1.2 KDF RFC7627 (CVL)	A5883	Hash Algorithm - SHA2-256, SHA2-384, SHA2-512	SP 800-135 Rev. 1
TLS v1.2 KDF RFC7627 (CVL)	A5889	Hash Algorithm - SHA2-256, SHA2-384, SHA2-512	SP 800-135 Rev. 1
TLS v1.3 KDF (CVL)	A5863	HMAC Algorithm - SHA2-256, SHA2-384 KDF Running Modes - DHE, PSK, PSK-DHE	SP 800-135 Rev. 1

Table 6: Approved Algorithms

**Vendor-Affirmed Algorithms:**

Name	Properties	Implementation	Reference
Asymmetric Cryptographic Key Generation (CKG)		N/A	SP 800-133 Rev. 2, section 4, example 1

Table 7: Vendor-Affirmed Algorithms

**Non-Approved, Allowed Algorithms:**

N/A for this module.

The module does not implement non-approved algorithms that are allowed in the approved mode of operation.

**Non-Approved, Allowed Algorithms with No Security Claimed:**

N/A for this module.

The module does not implement non-approved algorithms that are allowed in the approved mode of operation with no security claimed.

#### Non-Approved, Not Allowed Algorithms:

Name	Use and Function
AES GCM (external IV)	Authentication Encryption
HMAC (< 112-bit keys)	Message Authentication Code
KBKDF, KDA OneStep, KDA TwoStep, HKDF, ANS X9.42 KDF, ANS X9.63 KDF (< 112-bit keys)	Key Derivation
KDA OneStep, KDA TwoStep (SHAKE128, SHAKE256)	Key Derivation
ANS X9.42 KDF (SHAKE128, SHAKE256)	Key Derivation
ANS X9.63 KDF (SHA-1, SHAKE128, SHAKE256)	Key Derivation
SSH KDF (SHA-512/224, SHA-512/256, SHA-3, SHAKE128, SHAKE256)	Key Derivation
TLS 1.2 KDF (SHA-1, SHA-224, SHA-512/224, SHA-512/256, SHA-3)	TLS Key Derivation
TLS 1.3 KDF (SHA-1, SHA-224, SHA-512, SHA-512/224, SHA-512/256, SHA-3)	TLS Key Derivation
PBKDF2 (< 8 characters password; < 128 salt length; < 1000 iterations; < 112-bit keys)	Password-based Key Derivation
RSA and ECDSA (pre-hashed message)	Signature generation; Signature verification
RSA-PSS (invalid salt length: FIPS 186-5, section 5.4, item(g))	Signature generation; Signature verification

Table 8: Non-Approved, Not Allowed Algorithms

The table above lists all non-approved cryptographic algorithms of the module employed by the non-approved services of the Non-Approved Services table in Section 4.4 Non-Approved Services.

## 2.6 Security Function Implementations

Name	Type	Description	Properties	Algorithms
Symmetric Encryption with AES	BC-UnAuth	Symmetric encryption using AES	AES-ECB: 128-, 192-, 256-bit keys with 128, 192, 256 bits of security strength	AES-CBC: (A5398, A5399, A5400, A5401, A5402, A5403, A5658)

Name	Type	Description	Properties	Algorithms
			AES-CBC: 128-, 192-, 256-bit keys with 128, 192, 256 bits of security strength AES-CBC-CS1: 128-, 192-, 256-bit keys with 128, 192, 256 bits of security strength AES-CBC-CS2: 128-, 192-, 256-bit keys with 128, 192, 256 bits of security strength AES-CBC-CS3: 128-, 192-, 256-bit keys with 128, 192, 256 bits of security strength AES-CFB1: 128-, 192-, 256-bit keys with 128, 192, 256 bits of security strength AES-CFB128: 128-, 192-, 256-bit keys with 128, 192, 256 bits of security strength AES-CFB8: 128-, 192-, 256-bit keys with 128, 192, 256 bits of security strength AES-CTR: 128-, 192-, 256-bit keys with 128, 192, 256 bits of security strength AES-OFB: 128-, 192-, 256-bit keys with 128, 192, 256 bits of security strength AES-XTS Testing Revision 2.0: 256-, 512-bit keys with 128, 256 bits of security strength	AES-CBC-CS1: (A5398, A5399, A5400, A5401, A5402, A5403, A5658) AES-CBC-CS2: (A5398, A5399, A5400, A5401, A5402, A5403, A5658) AES-CBC-CS3: (A5398, A5399, A5400, A5401, A5402, A5403, A5658) AES-CFB1: (A5398, A5399, A5400, A5401, A5402, A5403, A5658) AES-CFB128: (A5398, A5399, A5400, A5401, A5402, A5403, A5658) AES-CFB8: (A5398, A5399, A5400, A5401, A5402, A5403, A5658) AES-CTR: (A5398, A5399, A5400, A5401, A5402, A5403, A5658) AES-ECB: (A5398, A5399, A5400, A5401, A5402, A5403, A5658, A5884, A5893, A5894, A5895, A5896, A5900) AES-OFB: (A5398, A5399, A5400, A5401, A5402, A5403, A5658) AES-XTS Testing Revision 2.0: (A5398, A5399,

© 2025 SUSE, LLC/atsec information security corporation.

This document can be reproduced and distributed only whole and intact, including this copyright notice.

Name	Type	Description	Properties	Algorithms
				A5400, A5401, A5402, A5403, A5658)
Symmetric Decryption with AES	BC-UnAuth	Symmetric decryption using AES	AES-ECB: 128-, 192-, 256-bit keys with 128, 192, 256 bits of security strength AES-CBC: 128-, 192-, 256-bit keys with 128, 192, 256 bits of security strength AES-CBC-CS1: 128-, 192-, 256-bit keys with 128, 192, 256 bits of security strength AES-CBC-CS2: 128-, 192-, 256-bit keys with 128, 192, 256 bits of security strength AES-CBC-CS3: 128-, 192-, 256-bit keys with 128, 192, 256 bits of security strength AES-CFB1: 128-, 192-, 256-bit keys with 128, 192, 256 bits of security strength AES-CFB128: 128-, 192-, 256-bit keys with 128, 192, 256 bits of security strength AES-CFB8: 128-, 192-, 256-bit keys with 128, 192, 256 bits of security strength AES-CTR: 128-, 192-, 256-bit keys with 128, 192, 256 bits of security strength AES-OFB: 128-, 192-, 256-bit keys with 128,	AES-CBC: (A5398, A5399, A5400, A5401, A5402, A5403, A5658) AES-CBC-CS1: (A5398, A5399, A5400, A5401, A5402, A5403, A5658) AES-CBC-CS2: (A5398, A5399, A5400, A5401, A5402, A5403, A5658) AES-CBC-CS3: (A5398, A5399, A5400, A5401, A5402, A5403, A5658) AES-CFB1: (A5398, A5399, A5400, A5401, A5402, A5403, A5658) AES-CFB128: (A5398, A5399, A5400, A5401, A5402, A5403, A5658) AES-CFB8: (A5398, A5399, A5400, A5401, A5402, A5403, A5658) AES-CTR: (A5398, A5399, A5400, A5401, A5402, A5403, A5658) AES-ECB: (A5398, A5399, A5400, A5401, A5402, A5403, A5658, A5884, A5893, A5894, A5895, A5896, A5900)

© 2025 SUSE, LLC/atsec information security corporation.

This document can be reproduced and distributed only whole and intact, including this copyright notice.

Name	Type	Description	Properties	Algorithms
			192, 256 bits of security strength AES-XTS Testing Revision 2.0: 256-, 512-bit keys with 128, 256 bits of security strength	AES-OFB: (A5398, A5399, A5400, A5401, A5402, A5403, A5658) AES-XTS Testing Revision 2.0: (A5398, A5399, A5400, A5401, A5402, A5403, A5658)
Key Derivation with KDA OneStep	KAS-56CKDF	Key Derivation using KDA OneStep	MACs: (HMAC) SHA-1, SHA-224, SHA-256, SHA-384, SHA-512, SHA-512/224, SHA-512/256, SHA3-224, SHA3-256, SHA3-384, SHA3-512 Shared secret length: 224-8192 bits Security strength: 112-256 bits	KDA OneStep SP800-56Cr2: (A5897)
Key Derivation with KDA TwoStep	KAS-56CKDF	Key Derivation using KDA TwoStep	Modes: feedback MACs: (HMAC) SHA-1, SHA-224, SHA-256, SHA-384, SHA-512, SHA-512/224, SHA-512/256, SHA3-224, SHA3-256, SHA3-384, SHA3-512 Shared secret length: 224-8192 bits Security strength: 112-256 bits	KDA TwoStep SP800-56Cr2: (A5897)
Key Derivation with X9.42 KDF	KAS-135KDF	Key Derivation using X9.42 KDF	Hashes: SHA-1, SHA2-224, SHA2-256, SHA2-384, SHA2-512, SHA2-512/224, SHA2-	KDF ANS 9.42: (A5868, A5869, A5876, A5877, A5878, A5879,

Name	Type	Description	Properties	Algorithms
			512/256 Shared secret length: 224-8192 bits Security strength: 112-256 bits	A5883, A5885, A5889)
Key Derivation with X9.63 KDF	KAS-135KDF	Key Derivation using X9.63 KDF	Hashes: SHA2-224, SHA2-256, SHA2-384, SHA2-512, SHA2-512/224, SHA2-512/256 Shared secret length: 224-8192 bits Security strength: 112-256 bits	KDF ANS 9.63: (A5868, A5869, A5876, A5877, A5878, A5879, A5883, A5885, A5889)
Key Derivation with SSH KDF	KAS-135KDF	Key Derivation	Ciphers: AES-128, AES-192, AES-256 Hashes: SHA-1, SHA2-224, SHA2-256, SHA2-384, SHA2-512 Shared secret length: 224-8192 bits Security strength: 112-256 bits	KDF SSH: (A5884, A5893, A5894, A5895, A5896, A5900)
Key Derivation with HKDF	KAS-56CKDF	Key Derivation using HKDF	MACs: HMAC with SHA-1, SHA2-224, SHA2-256, SHA2-384, SHA2-512, SHA2-512/224, SHA2-512/256, SHA3-224, SHA3-256, SHA3-384, SHA3-512 Shared secret length: 224-8192 bits Security strength: 112-256 bits	KDA HKDF SP800-56Cr2: (A5863)

Name	Type	Description	Properties	Algorithms
TLS Key Derivation	KAS-135KDF	TLS 1.2 / 1.3 Key Derivation	TLS v1.2 KDF RFC7627: Hashes: SHA2-256, SHA2-384, SHA2-512; Support: extended master secret TLS v1.3 KDF: Modes: DHE, PSK, PSK-DHE; Hashes: SHA2-256, SHA2-384 Shared secret length: 224-8192 bits Security strength: 112-256 bits	TLS v1.3 KDF: (A5863) TLS v1.2 KDF RFC7627: (A5868, A5876, A5877, A5878, A5879, A5883, A5889)
Key Derivation with KBKDF	KBKDF	Key derivation using KBKDF	Modes: Counter, Feedback MACs: CMAC with AES-128, AES-192, AES-256 and HMAC with SHA-1, SHA2-224, SHA2-256, SHA2-384, SHA2-512, SHA2-512/224, SHA2-512/256, SHA3-224, SHA3-256, SHA3-384, SHA3-512 KDK length: 112-4096 bits Security strength: 112-256 bits	KDF SP800-108: (A5899)
Password-based Key Derivation	PBKDF	Password-based Key Derivation	Option: 1a Password length: 20-128 characters Salt length: 128-4096 bits Iteration count: 1000-10000 Hashes: SHA-1, SHA2-224, SHA2-	PBKDF: (A5868, A5869, A5876, A5877, A5878, A5879, A5883, A5885, A5889)

Name	Type	Description	Properties	Algorithms
			256, SHA2-384, SHA2-512, SHA2-512/224, SHA2-512/256, SHA3-224, SHA3-256, SHA3-384, SHA3-512 Derived-key length: 112-4096 bits Security strength: 112-256 bits	
Random Number Generation	DRBG	Random Number Generation	Counter DRBG: AES-128, AES-192, AES-256, with/without derivation function, with/without prediction resistance; Internal state length: 256, 320, 384 bits; Security strength: 128, 192, 256 bits HMAC DRBG: SHA-1, SHA-256, SHA-512 with/without prediction resistance; Internal state length: 320, 512, 1024 bits; Security strength: 128, 256 bits Hash DRBG: SHA-1, SHA-256, SHA-512 with/without prediction resistance; Internal state length: 880, 1776 bits; Security strength: 128, 256 bits	Counter DRBG: (A5397) HMAC DRBG: (A5397) Hash DRBG: (A5397)

Name	Type	Description	Properties	Algorithms
Signature Generation	DigSig-SigGen	Signature Generation	ECDSA SigGen (FIPS 186-5): Curves: P-224, P-256, P-384, P-521; Hashes: SHA-224, SHA-256, SHA-384, SHA-512, SHA-512/224, SHA-512/256, SHA3-224, SHA3-256, SHA3-384, SHA3-512; Security strength: 112, 128, 192, 256 bits RSA SigGen (FIPS 186-5): Padding: PKCS#1 v1.5 and PSS; Moduli: 2048-16384 bits; Hashes: SHA-224, SHA-256, SHA-384, SHA-512, SHA-512/224, SHA-512/256, SHA3-224, SHA3-256, SHA3-384, SHA3-512; Security strength: 112-256 bits IG C.F Compliance: The module supports RSA modulus sizes which are not tested by CAVP in compliance with FIPS 140-3 IG C.F	ECDSA SigGen (FIPS186-5): (A5868, A5869, A5876, A5877, A5878, A5879, A5883, A5885, A5889) RSA SigGen (FIPS186-5): (A5868, A5869, A5876, A5877, A5878, A5879, A5883, A5885, A5889)
Signature Verification	DigSig-SigVer	Signature Verification	ECDSA SigVer (FIPS 186-5): Curves: P-224, P-256, P-384, P-521; Hashes: SHA-224, SHA-256, SHA-384, SHA-512, SHA-512/224, SHA-	ECDSA SigVer (FIPS186-5): (A5868, A5869, A5876, A5877, A5878, A5879, A5883, A5885, A5889) RSA SigVer (FIPS186-2):

Name	Type	Description	Properties	Algorithms
			512/256, SHA3-224, SHA3- 256, SHA3-384, SHA3-512; Security strength: 112, 128, 192, 256 bits RSA SigVer (FIPS 186-5): NIST SP 800-131A Rev. 2 Acceptable; Padding: PKCS#1 v1.5 and PSS; Moduli: 2048-16384 bits; Hashes: SHA-224, SHA-256, SHA-384, SHA-512, SHA-512/224, SHA-512/256, SHA3-224, SHA3- 256, SHA3-384, SHA3-512; Security strength: 112-256 bits RSA SigVer (FIPS 186-2) and RSA SigVer (FIPS 186-4): NIST SP 800-131A Rev. 2 Legacy use; Padding: PKCS#1 v1.5 and PSS; Moduli: 1024-2047 bits; Hashes: SHA-224, SHA-256, SHA-384, SHA-512; Security strength: 80-111 bits IG C.F Compliance: The module supports RSA modulus sizes which are not tested by CAVP in compliance with FIPS 140-3 IG C.F	(A5868, A5876, A5877, A5878, A5879, A5883, A5889) RSA SigVer (FIPS186-4): (A5868, A5876, A5877, A5878, A5879, A5883, A5889) RSA SigVer (FIPS186-5): (A5868, A5869, A5876, A5877, A5878, A5879, A5883, A5885, A5889)

Name	Type	Description	Properties	Algorithms
Message Authentication Code	MAC	Message Authentication Code	HMAC: Hashes: SHA-1, SHA-224, SHA-256, SHA-384, SHA-512, SHA-512/224, SHA-512/256, SHA3-224, SHA3-256, SHA3-384, SHA3-512; Key length: 112-524288 bits; Security strength: 112-256 bits AES CMAC and GMAC: Key length: 128, 192, 256 bits; Security strength: 128, 192, 256 bits	HMAC-SHA-1: (A5868, A5876, A5877, A5878, A5879, A5883, A5889) HMAC-SHA2-224: (A5868, A5876, A5877, A5878, A5879, A5883, A5889) HMAC-SHA2-256: (A5864, A5868, A5876, A5877, A5878, A5879, A5883, A5889) HMAC-SHA2-384: (A5868, A5876, A5877, A5878, A5879, A5883, A5889) HMAC-SHA2-512: (A5868, A5876, A5877, A5878, A5879, A5883, A5889) HMAC-SHA2-512/224: (A5868, A5876, A5877, A5878, A5879, A5883, A5889) HMAC-SHA2-512/256: (A5868, A5876, A5877, A5878, A5879, A5883, A5889) HMAC-SHA3-224: (A5869, A5885) HMAC-SHA3-256: (A5869, A5885) HMAC-SHA3-384: (A5869, A5885) HMAC-SHA3-512: (A5869, A5885) AES-CMAC:

Name	Type	Description	Properties	Algorithms
				(A5398, A5399, A5400, A5401, A5402, A5403, A5658) AES-GMAC: (A5870, A5871, A5872, A5873, A5874, A5875, A5880, A5881, A5882, A5886, A5887, A5888, A5903, A5904, A5905)
Message digest	SHA XOF	Message digest	Hashes: SHA-1, SHA-224, SHA-256, SHA-384, SHA-512, SHA-512/224, SHA-512/256, SHA3-224, SHA3-256, SHA3-384, SHA3-512 XOFs: SHAKE-128, SHAKE-256	SHA-1: (A5868, A5876, A5877, A5878, A5879, A5883, A5889) SHA2-224: (A5868, A5876, A5877, A5878, A5879, A5883, A5889) SHA2-256: (A5864, A5868, A5876, A5877, A5878, A5879, A5883, A5889) SHA2-384: (A5868, A5876, A5877, A5878, A5879, A5883, A5889) SHA2-512: (A5868, A5876, A5877, A5878, A5879, A5883, A5889) SHA2-512/224: (A5868, A5876, A5877, A5878, A5879, A5883, A5889) SHA2-512/256: (A5868, A5876, A5877, A5878, A5879, A5883, A5889) SHA3-224: (A5869, A5885) SHA3-256: (A5869, A5885)

© 2025 SUSE, LLC/atsec information security corporation.

This document can be reproduced and distributed only whole and intact, including this copyright notice.

Name	Type	Description	Properties	Algorithms
				SHA3-384: (A5869, A5885) SHA3-512: (A5869, A5885) SHAKE-128: (A5869, A5885) SHAKE-256: (A5869, A5885)
Authenticated Symmetric Encryption	BC-Auth	Authenticated Symmetric Encryption	Key Length: 128, 192, 256 bits Security strength: 128, 192, 256 bits	AES-CCM: (A5398, A5399, A5400, A5401, A5402, A5403, A5658) AES-GCM: (A5870, A5871, A5872, A5873, A5874, A5875, A5880, A5881, A5882, A5886, A5887, A5888, A5903, A5904, A5905) AES-KW: (A5398, A5399, A5400, A5401, A5402, A5403, A5658) AES-KWP: (A5398, A5399, A5400, A5401, A5402, A5403, A5658)
Authenticated Symmetric Decryption	BC-Auth	Authenticated Symmetric Decryption	Key Length: 128, 192, 256 bits Security strength: 128, 192, 256 bits	AES-GCM: (A5870, A5871, A5872, A5873, A5874, A5875, A5880, A5881, A5882, A5886, A5887, A5888, A5903, A5904, A5905) AES-CCM: (A5398, A5399, A5400, A5401, A5402, A5403, A5658) AES-KW: (A5398, A5399, A5400, A5401,

Name	Type	Description	Properties	Algorithms
				A5402, A5403, A5658) AES-KWP: (A5398, A5399, A5400, A5401, A5402, A5403, A5658)
Key Pair Generation with ECDSA	AsymKeyPair-KeyGen CKG	Key Pair Generation using ECDSA	Mode: FIPS 186-5 A.2.2: Rejection Sampling Curves: P-224, P-256, P-384, P-521 Security strength: 112, 128, 192, 256 bits	ECDSA KeyGen (FIPS186-5): (A5868, A5876, A5877, A5878, A5879, A5883, A5889) Asymmetric Cryptographic Key Generation (CKG): ()
Key Pair Generation with RSA	AsymKeyPair-KeyGen CKG	Key Pair Generation using RSA	Mode: FIPS 186-5, A.1.6: Probable Primes Based on Auxiliary Probable Moduli: 2048-15360 bits Security strength: 112-256 bits IG C.F Compliance: The module supports RSA modulus sizes which are not tested by CAVP in compliance with FIPS 140-3 IG C.F	RSA KeyGen (FIPS186-5): (A5868, A5876, A5877, A5878, A5879, A5883, A5889) Asymmetric Cryptographic Key Generation (CKG): ()
Key Pair Generation with Safe Primes	AsymKeyPair-KeyGen CKG	Key Pair Generation using Safe Primes	Mode: Testing Candidates (SP 800-56Arev3 Appendix 5.6.1.1.4) Groups: ffdhe2048, ffdhe3072, ffdhe4096, ffdhe6144, ffdhe8192,	Safe Primes Key Generation: (A5898) Asymmetric Cryptographic Key Generation (CKG): ()

Name	Type	Description	Properties	Algorithms
			MODP-2048, MODP-3072, MODP-4096, MODP-6144, MODP-8192 Security strength: 112- 200 bits	
Key Pair Verification with ECDSA	AsymKeyPair- KeyVer	Key Pair Verification using ECDSA	Mode: FIPS 186-5 A.2.2: Rejection Sampling Curves: P-224, P- 256, P-384, P- 521 Security strength: 112, 128, 192, 256 bits	ECDSA KeyVer (FIPS186-5): (A5868, A5876, A5877, A5878, A5879, A5883, A5889)
Key Pair Verification with Safe Primes	AsymKeyPair- KeyVer	Key Pair Verification using Safe Primes	Mode: Testing Candidates (SP 800-56Arev3 Appendix 5.6.1.1.4) Groups: ffdhe2048, ffdhe3072, ffdhe4096, ffdhe6144, ffdhe8192, MODP-2048, MODP-3072, MODP-4096, MODP-6144, MODP-8192 Security strength: 112- 200 bits	Safe Primes Key Verification: (A5898)
Shared Secret Computation with DH	KAS-SSC	Shared Secret Computation using DH	Compliance: SP 800-56A Rev. 3, FIPS 140-3 IG D.F. Scenario 2 (1) Scheme: dpEphem KAS Role: initiator, responder Groups:	KAS-FFC-SSC Sp800-56Ar3: (A5898)

Name	Type	Description	Properties	Algorithms
			ffdhe2048, ffdhe3072, ffdhe4096, ffdhe6144, ffdhe8192, MODP-2048, MODP-3072, MODP-4096, MODP-6144, MODP-8192 Security strength: 112- 200 bits	
Shared Secret Computation with ECDH	KAS-SSC	Shared Secret Computation using EC Diffie-Hellman	Compliance: SP 800-56A Rev. 3, FIPS 140-3 IG D.F. Scenario 2 (1) Scheme: ephemeralUnified KAS Role: initiator, responder Curves: P-224, P-256, P-384, P-521 Security strength: 112, 128, 192, 256 bits	KAS-ECC-SSC Sp800-56Ar3: (A5868, A5876, A5877, A5878, A5879, A5883, A5889)
Shared Secret Computation with RSA	KAS-SSC	Shared Secret Computation using RSA		KAS-IFC-SSC: (A5868, A5876, A5877, A5878, A5879, A5883, A5889)
Asymmetric Encryption with RSA	KTS-Encap	Asymmetric encryption using RSA		KTS-IFC: (A5868, A5876, A5877, A5878, A5879, A5883, A5889)
Asymmetric Decryption with RSA	KTS-Decap	Asymmetric decryption using RSA		KTS-IFC: (A5868, A5876, A5877, A5878, A5879, A5883, A5889)

Table 9: Security Function Implementations

© 2025 SUSE, LLC/atsec information security corporation.

This document can be reproduced and distributed only whole and intact, including this copyright notice.

## 2.7 Algorithm Specific Information

### 2.7.1 AES GCM IV

For TLS 1.2, the module offers the AES GCM implementation and uses the context of Scenario 1 of FIPS 140-3 IG C.H. The module is compliant with SP 800-52 Rev. 2 Section 3.3.1 and the mechanism for IV generation is compliant with RFC 5288 and 8446.

The module does not implement the TLS protocol. The module's implementation of AES GCM is used together with an application that runs outside the module's cryptographic boundary. The design of the TLS protocol implicitly ensures that the counter (the `nonce_explicit` part of the IV) does not exhaust the maximum number of possible values for a given session key.

In the event the module's power is lost and restored, the consuming application must ensure that a new key for use with the AES GCM key encryption or decryption under this scenario shall be established.

Alternatively, the Crypto Officer can use the module's API to perform AES GCM encryption using internal IV generation. These IVs are always 96 bits and generated using the approved DRBG internal to the module's boundary, compliant to Scenario 2 of FIPS 140-3 IG C.H.

The module also provides a non-approved AES GCM encryption service which accepts arbitrary external IVs from the operator. This service can be requested by invoking the `EVP_EncryptInit_ex2` API function with a non-NULL IV value. When this is the case, the API will set a non-approved service indicator.

Finally, for TLS 1.3, the AES GCM implementation uses the context of Scenario 5 of FIPS 140-3 IG C.H. The protocol that provides this compliance is TLS 1.3, defined in RFC8446 of August 2018, using the cipher-suites that explicitly select AES GCM as the encryption/decryption cipher (Appendix B.4 of RFC8446). The module supports acceptable AES GCM cipher suites from Section 3.3.1 of SP 800-52 Rev. 2. The module's implementation of AES GCM is used together with an application that runs outside the module's cryptographic boundary. The design of the TLS protocol implicitly ensures that the counter (the `nonce_explicit` part of the IV) does not exhaust the maximum number of possible values for a given session key.

### 2.7.2 AES XTS

The length of a single data unit encrypted or decrypted with AES XTS shall not exceed  $2^{20}$  AES blocks, that is 16MB, of data per XTS instance. An XTS instance is defined in Section 4 of SP 800-38E.

To meet the requirement stated in IG C.I, the module implements a check that ensures, before performing any cryptographic operation, that the two AES keys used in AES XTS mode are not identical. As the module does not generate symmetric keys, the check is performed when keys are input the service APIs.

`Key_1` and `Key_2` shall be generated and/or established independently according to the rules for component symmetric keys from NIST SP 800-133rev2, Sec. 6.3.

The XTS mode shall only be used for the cryptographic protection of data on storage devices. It shall not be used for other purposes, such as the encryption of data in transit.

### 2.7.3 Key Derivation using SP 800-132 PBKDF2

The module provides password-based key derivation (PBKDF2), compliant with SP 800-132. The module supports option 1a from Section 5.4 of SP 800-132, in which the Master Key (MK) or a segment of it is used directly as the Data Protection Key (DPK). In accordance to SP 800-132 and FIPS 140-3 IG D.N, the following requirements are met:

- Derived keys shall be used only for storage applications, and shall not be used for any other purposes. The length of the MK or DPK is 112 bits or more.
- Passwords or passphrases, used as an input for the PBKDF2, shall not be used as cryptographic keys.
- The minimum length of the password or passphrase accepted by the module is 8 characters. The probability of guessing the value, assuming a worst-case scenario of all digits, is estimated to be at most  $10^{-8}$ . Combined with the minimum iteration count as described below, this provides an acceptable trade-off between user experience and security against brute-force attacks.
- A portion of the salt shall be generated randomly using the SP 800-90A Rev. 1 DRBG provided by the module. The minimum length required is 128 bits.
- The iteration count shall be selected as large as possible, as long as the time required to generate the key using the entered password is acceptable for the users. The minimum value accepted by the module is 1000.

If any of these requirements are not met, the requested service is non-approved (see Non-Approved Services table in Section 4.4 Non-Approved Services).

#### **2.7.4 SP 800-56A Rev. 3 Assurances**

To comply with the assurances found in Section 5.6.2 of SP 800-56A Rev. 3, the operator must use the module together with an application that implements the TLS protocol. Additionally, the module's approved key pair generation service (see Approved Services table in Section 4.3 Approved Services) must be used to generate ephemeral Diffie-Hellman or EC Diffie-Hellman key pairs, or the key pairs must be obtained from another FIPS-validated module. As part of this service, the module will internally perform the full public key validation of the generated public key.

The module's shared secret computation service will internally perform the full public key validation of the peer public key, complying with Sections 5.6.2.2.1 and 5.6.2.2.2 of SP 800-56A Rev. 3.

#### **2.7.5 SHA-3**

The module implements the SHA-3 algorithms as both standalone and part of higher-level algorithms (in compliance with FIPS 140-3 IG C.C). As detailed in Section 2.6 Security Function Implementations with corresponding certificates, the cryptographic algorithms that use of SHA-3 include RSA signature generation and verification, ECDSA signature generation and verification, KBKDF, KDA HKDF, X9.63 KDF, X9.42 KDF, PBKDF, OneStep KDA, and HMAC. In addition, the implementation of the extendable output functions SHAKE128 and SHAKE256 were verified to have a standalone usage.

#### **2.7.6 RSA Signatures**

The module supports RSA Signature Verification for 1024, 1280, 1536 and 1792-bit keys. This is allowed by FIPS 140-3 IG C.F. Specifically, 1280 and 1792 cannot be CAVP tested but are approved for signature verification in IG C.F.

The 1024-bit modulus has been CAVP tested for RSA signature verification in compliance with FIPS 186-4, while the 1536-bit modulus has been CAVP tested for RSA signature verification in compliance with FIPS 186-2.

For all other approved moduli (namely 2048, 3072, and 4096 bit keys) supported by the module, RSA signature verification is approved and CAVP tested in compliance with FIPS 186-5.

### 2.7.7 RSA Key Agreement

To comply with the assurances found in Section 6.4 of SP 800-56B Rev. 2, the module's approved RSA key pair generation service (see Table 9) must be used to generate the RSA key pairs, or the key pairs must be obtained from another FIPS-validated module. As part of this service, the module will internally perform the key pair validity and the pairwise consistency according to Section 6.4.1.1 of SP 800-56B Rev. 2.

Additionally, the entity requesting the shared secret computation service shall verify the validity of the peer's public key using the public key validation service of the module (EVP\_PKEY\_check() API). This service will perform the full public key validation of the peer's public key, complying with Section 6.4.2.1 of SP 800-56B Rev. 2.

### 2.7.8 Compliance to SP 800-56Br2 Assurances

To comply with the assurances found in Section 6.4 of SP 800-56Br2, the operator must use the module in the context of the TLS or SSH protocols. Additionally, the module's approved key pair generation service (see Section 4.3) must be used to generate RSA key pairs, or the key pairs must be obtained from another FIPS-validated module. As part of this service, the module will internally perform the key pair validation of the generated public key.

The operator must use the EVP\_PKEY\_public\_check() API to perform partial public key validation of the peer public key, complying with Section 6.4.2.2 of SP 800-56Br2. The operator must also confirm the peer's possession of private key by using any method specified in Section 6.4.2.3 of SP 800-56Br2.

### 2.7.9 Key Transport and Key Agreement

The module does not establish SSPs using an approved key transport scheme (KTS). However, it does offer approved authenticated algorithms that can be used by an external operator/application as part of an approved KTS.

The module does not establish SSPs using an approved key agreement scheme (KAS). However, it does offer some or all of the underlying KAS cryptographic functionality to be used by an external operator/application as part of an approved KAS.

### 2.7.10 SHA-1 Use

SHA-1 is only approved when used in approved modes for message digest, HMAC, HKDF, KDA OneStep/TwoStep, PBKDF, SSH KDF, ANS x9.42 KDF, KBKDF, Hash DRBG, HMAC DRBG, RSA OAEP. The use of SHA-1 for digital signature generation (e.g., ECDSA, RSA, EdDSA) or verification is non-approved.

## 2.8 RBG and Entropy

Cert Number	Vendor Name
E177	SUSE LLC

Table 10: Entropy Certificates

Name	Type	Operational Environment	Sample Size	Entropy per Sample	Conditioning Component
SUSE OpenSSL CPU Time Jitter RNG Entropy Source	Non-Physical	SUSE Linux Enterprise Server 15 SP6 on AMD EPYC™ 7343; SUSE Linux Enterprise Server 15 SP6 on Ampere® Altra® Q80-30; SUSE Linux Enterprise Server 15 SP6 on Intel® Xeon® Gold 5416S; SUSE Linux Enterprise Server 15 SP6 on IBM® Telum™	256 bits	full entropy	AES-256-CTR-DRBG (A5397); SHA3-256 (A5411)

Table 11: Entropy Sources

As per the Public document of entropy certificate E177, the entropy source provides full entropy of 256 bits.

In addition to the DRBG algorithms provided to the operator, the module internally uses two dedicated DRBG instances based on SP 800-90A Rev. 1 to generate seeds for asymmetric key pairs and random numbers for security functions. The following parameters are used:

1. Private DRBG: AES-256 CTR\_DRBG with derivation function. This DRBG is used to generate secret random values (e.g. during asymmetric key pair generation). It can be accessed using `RAND_priv_bytes`.
2. Public DRBG: AES-256 CTR\_DRBG with derivation function. This DRBG is used to generate general purpose random values that do not need to remain secret (e.g. initialization vectors). It can be accessed using `RAND_bytes`.

## 2.9 Key Generation

The module implements asymmetric key pair generation compliant with SP 800-133 Rev. 2 as listed in the Security Function Implementations table in 2.6 Security Function Implementations.

When random values are required, they are obtained from the SP 800-90A Rev. 1 approved DRBG, compliant with Section 4 of SP 800-133 Rev. 2 (without XOR).

Intermediate key generation values are not output from the module and are explicitly zeroized after processing the service.

## 2.10 Key Establishment

The module provides Diffie-Hellman (DH) and Elliptic Curve Diffie-Hellman (ECDH) shared secret computation compliant with SP 800-56A Rev. 3, in accordance with scenario 2 (1) of FIPS 140-3 IG D.F.

For Diffie-Hellman, the module supports the use of the safe primes defined in RFC 3526 (IKE) and RFC 7919 (TLS). Note that the module only implements key pair generation, key pair verification, and shared secret computation. No other part of the IKE or TLS protocols is implemented (with the exception of the TLS 1.2 and 1.3 KDFs):

- IKE (RFC 3526):
  - MODP-2048 (ID = 14)
  - MODP-3072 (ID = 15)
  - MODP-4096 (ID = 16)
  - MODP-6144 (ID = 17)
  - MODP-8192 (ID = 18)
- TLS (RFC 7919)
  - ffdhe2048 (ID = 256)
  - ffdhe3072 (ID = 257)
  - ffdhe4096 (ID = 258)
  - ffdhe6144 (ID = 259)
  - ffdhe8192 (ID = 260)

For Elliptic Curve Diffie-Hellman, the module supports the NIST-defined P-224, P-256, P-384, and P-521 curve.

According to FIPS 140-3 IG D.B, the key sizes of DH and ECDH shared secret computation provide respectively 112-200 and 112-256 bits of security strength in an approved mode of operation.

In addition, the module provides RSA shared secret computation compliant with SP 800-56B Rev. 2, in accordance with scenario 1 (1) of FIPS 140-3 IG D.F.

For RSA key generation, the module provides 2048-15360 bits keys. Therefore, according to FIPS 140-3 IG D.B, the key sizes of RSA shared secret computation provide 112-256 bits of security strength in the approved mode of operation.

## 2.11 Industry Protocols

The module implements the SSH key derivation function for use in the SSH protocol (RFC 4253 and RFC 6668).

GCM with internal IV generation in the approved mode is compliant with versions 1.2 and 1.3 of the TLS protocol (RFC 5288 and 8446) and shall only be used in conjunction with the TLS protocol. Additionally, the module implements the TLS 1.2 and TLS 1.3 key derivation functions for use in the TLS protocol.

No parts of the SSH, TLS, or IKE protocols, other than those mentioned above, have been tested by the CAVP and CMVP.

## 3 Cryptographic Module Interfaces

### 3.1 Ports and Interfaces

Physical Port	Logical Interface(s)	Data That Passes
N/A	Data Input	API input parameters
N/A	Data Output	API output parameters
N/A	Control Input	API function calls
N/A	Status Output	API return codes, error queue

Table 12: Ports and Interfaces

The logical interfaces are the APIs through which the applications request services. These logical interfaces are logically separated from each other by the API design. The module does not implement a control output interface.

## 4 Roles, Services, and Authentication

### 4.1 Authentication Methods

N/A for this module.

The module does not support authentication methods.

### 4.2 Roles

Name	Type	Operator Type	Authentication Methods
Crypto Officer	Role	CO	None

Table 13: Roles

The module supports the Crypto Officer role only. This sole role is implicitly and always assumed by the operator of the module when performing a service. The module does not support multiple concurrent operators.

### 4.3 Approved Services

Name	Description	Indicator	Inputs	Outputs	Security Functions	SSP Access
Symmetric Encryption	Used to perform symmetric encryption of an entry plaintext	EVP_EncryptFinal_ex returns 1	Plaintext, AES key, IV	Ciphertext	Symmetric Encryption with AES	Crypto Officer - AES key: W,E
Symmetric Decryption	Used to perform symmetric decryption of an entry ciphertext	EVP_DecryptFinal_ex returns 1	Ciphertext, AES key, IV	Plaintext	Symmetric Decryption with AES	Crypto Officer - AES key: W,E

Name	Description	Indicator	Inputs	Outputs	Security Functions	SSP Access
Authenticated Encryption	Used to perform authenticated symmetric encryption with AES	AES-GCM: EVP_CIPHER_SUSE_FIPS_INDICATOR_APPROVED; Others: EVP_EncryptFinal_ex returns 1	Plaintext, AES key, IV	Ciphertext, MAC tag	Authenticated Symmetric Encryption	Crypto Officer - AES key: W,E
Authenticated Decryption	Used to perform authenticated symmetric decryption with AES	AES-GCM: EVP_CIPHER_SUSE_FIPS_INDICATOR_APPROVED; Others: EVP_DecryptFinal_ex returns 1	Ciphertext, AES key, IV, MAC tag	Plaintext or failure	Authenticated Symmetric Decryption	Crypto Officer - AES key: W,E
Message Authentication Code	Compute a MAC tag	HMAC: EVP_MAC_SUSE_FIPS_INDICATOR_APPROVED; Others: EVP_MAC_final returns 1	Message, AES key or HMAC key	MAC tag	Message Authentication Code	Crypto Officer - HMAC key: W,E - AES key: W,E
Message Digest	Used to generate a SHA-1, SHA-2, or SHA-3/SHAKE message digest	EVP_DigestFinal_ex returns 1	Message	Message digest	Message digest	Crypto Officer
Key Derivation with KBKDF	Derive a key from a key-derivation key	EVP_KDF_SUSE_FIPS_INDICATOR_APPROVED	Key-derivation key	KBKDF Derived Key	Key Derivation with KBKDF	Crypto Officer - Key Derivation Key: W,E -

Name	Description	Indicator	Inputs	Outputs	Security Functions	SSP Access
						KBKDF Derived Key: G,R
Key Derivation with HKDF	Derive a key from a shared secret using HKDF	EVP_KDF_SUSE_FIPS_INDICATOR_APPROVED	Shared secret	HKDF Derived Key	Key Derivation with HKDF	Crypto Officer - Shared Secret: W,E - HKDF Derived Key: G,R
Key Derivation with SSH KDF	Derive a key from a shared secret using SSH KDF	EVP_KDF_SUSE_FIPS_INDICATOR_APPROVED	Shared secret	SSH Derived Key	Key Derivation with SSH KDF	Crypto Officer - Shared Secret: W,E - SSH Derived Key: G,R
Key Derivation with X9.63 KDF	Derive a key from a shared secret using X9.63 KDF	EVP_KDF_SUSE_FIPS_INDICATOR_APPROVED	Shared secret	X9.63 Derived Key	Key Derivation with X9.63 KDF	Crypto Officer - Shared Secret: W,E - X9.63 Derived Key: G,R
Key Derivation with X9.42 KDF	Derive a key from a shared secret using X9.63 KDF	EVP_KDF_SUSE_FIPS_INDICATOR_APPROVED	Shared secret	X9.42 Derived Key	Key Derivation with X9.42 KDF	Crypto Officer - Shared Secret: W,E - X9.42 Derived Key: G,R

Name	Description	Indicator	Inputs	Outputs	Security Functions	SSP Access
Key Derivation with KDA OneStep	Derive a key from a shared secret using KDA OneStep	EVP_KDF_SUSE_FIPS_INDICATOR_APPROVED	Shared secret	KDA OneStep Derived Key	Key Derivation with KDA OneStep	Crypto Officer - Shared Secret: W,E - KDA OneStep Derived Key: G,R
Key Derivation with KDA TwoStep	Derive a key from a shared secret using KDA TwoStep	EVP_KDF_SUSE_FIPS_INDICATOR_APPROVED	Shared secret	KDA TwoStep Derived Key	Key Derivation with KDA TwoStep	Crypto Officer - Shared Secret: W,E - KDA TwoStep Derived Key: G,R
TLS Key Derivation	Derive a key from a shared secret using TLS 1.2 KDF / TLS 1.3 KDF	EVP_KDF_SUSE_FIPS_INDICATOR_APPROVED	Shared secret	TLS Derived Key	TLS Key Derivation	Crypto Officer - Shared Secret: W,E - TLS Derived Key: G,R
Password-based Key Derivation	Derive a key from a password	EVP_KDF_SUSE_FIPS_INDICATOR_APPROVED	Password or passphrase	PBKDF Derived Key	Password-based Key Derivation	Crypto Officer - Password or passphrase: W,E - PBKDF Derive

Name	Description	Indicator	Inputs	Outputs	Security Functions	SSP Access
						d Key: G,R
Shared Secret Computation with DH	Compute a shared secret	EVP_PKEY_derive returns 1	DH private key, DH public key (peer)	Shared secret	Shared Secret Computation with DH	Crypto Officer - DH Private key: W,E - DH Public key: W,E - Shared Secret: G,R
Shared Secret Computation with ECDH	Compute a shared secret	EVP_PKEY_derive returns 1	EC private key, EC public key (peer)	Shared secret	Shared Secret Computation with ECDH	Crypto Officer - EC Private key: W,E - EC Public key: W,E - Shared Secret: G,R
Shared Secret Computation with RSA	Compute a shared secret	EVP_PKEY_derive returns 1	RSA private key, RSA public key (peer)	Shared secret	Shared Secret Computation with RSA	Crypto Officer - RSA private key: W,E - RSA public key: W,E - Shared Secret: G,R

Name	Description	Indicator	Inputs	Outputs	Security Functions	SSP Access
Asymmetric Encryption	Perform RSA-based encryption (compliant with SP 800-56B Rev. 2))	EVP_PKEY_encrypt returns 1	RSA public key (peer), plaintext key	Encapsulated key	Asymmetric Encryption with RSA	Crypto Officer - RSA public key: W,E
Asymmetric Decryption	Perform RSA-based decryption (compliant with SP 800-56B Rev. 2))	EVP_PKEY_decrypt returns 1	RSA private key (owner), encapsulated key	Plaintext key	Asymmetric Decryption with RSA	Crypto Officer - RSA private key: W,E
Signature Generation	Generate a digital signature	EVP_SIGNATURE_SUSE_FIPS_INDICATOR_APPROVED	Message, private key	Signature	Signature Generation	Crypto Officer - RSA private key: W,E - EC Private key: W,E
Signature Verification	Verify a digital signature	EVP_SIGNATURE_SUSE_FIPS_INDICATOR_APPROVED	Message, public key, signature	Pass/fail	Signature Verification	Crypto Officer - RSA public key: W,E - EC Public key: W,E

Name	Description	Indicator	Inputs	Outputs	Security Functions	SSP Accesses
Key Pair Generation	Generate a key pair	EVP_PKEY_Generate returns 1	Group or Curve or Modulus bits	DH key pair; EC key pair; RSA key pair	Key Pair Generation with RSA Key Pair Generation with ECDSA Key Pair Generation with Safe Primes	Crypto Officer - Module - generated RSA private key: G,R - Module - generated DH Private key: G,R - Module - generated RSA public key: G,R - Module - generated DH Public key: G,R - Module - generated EC Private key: G,R - Module - genera

Name	Description	Indicator	Inputs	Outputs	Security Functions	SSP Access
						ted EC Public key: G,R - Intermediate key generation value: G,E,Z
Key Pair Verification with Safe Primes	Verify a key pair generated with Safe Primes	EVP_PKEY_public_check or EVP_PKEY_private_check or EVP_PKEY_check returns 1	Key pair	Pass/fail	Key Pair Verification with Safe Primes	Crypto Officer - DH Public key: W,E - DH Private key: W,E
Key Pair Verification with ECDSA	Verify a key pair generated with ECDSA	EVP_PKEY_public_check or EVP_PKEY_private_check or EVP_PKEY_check returns 1	Key pair	Pass/fail	Key Pair Verification with ECDSA	Crypto Officer - EC Public key: W,E - EC Private key: W,E
Key Pair Verification with RSA	Verify a key pair generated with RSA	EVP_PKEY_public_check or EVP_PKEY_private_check or EVP_PKEY_check returns 1	Key pair	Pass/fail		Crypto Officer - RSA public key: W,E - RSA private key: W,E

Name	Description	Indicator	Inputs	Outputs	Security Functions	SSP Access
Random Number Generation	Generate random bytes	EVP RAND_generate returns 1	Output length	Random bytes	Random Number Generation	Crypto Officer - Entropy input: W,E - DRBG internal state (V value, C value): G,W,E - DRBG internal state (V value, Key): G,W,E - DRBG seed: G,W,E
Show status	Show the current status of the module	None	N/A	Module status	None	Crypto Officer
Show module name and version	Show module name and the version of the module	None	N/A	Name and version information	None	Crypto Officer
Self-test	Perform CASTs and integrity test	None	N/A	Pass/fail result of self-tests	Message digest Message Authentication Code	Crypto Officer

Name	Description	Indicator	Inputs	Outputs	Security Functions	SSP Access
					Symmetric Encryption with AES Symmetric Decryption with AES Authenticated Symmetric Encryption Authenticated Symmetric Decryption Signature Generation Signature Verification Key Derivation with KBKDF Key Derivation with KDA OneStep Key Derivation with HKDF Key Derivation with X9.42 KDF	

© 2025 SUSE, LLC/atsec information security corporation.

This document can be reproduced and distributed only whole and intact, including this copyright notice.

Name	Description	Indicator	Inputs	Outputs	Security Functions	SSP Access
					Key Derivation with X9.63 KDF Key Derivation with SSH KDF TLS Key Derivation Password-based Key Derivation Random Number Generation Shared Secret Computation with DH Shared Secret Computation with ECDH	
Zeroization	Zeroize SSPs.	None	Any SSP	N/A	None	Crypto Officer - AES key: Z - HMAC key: Z - RSA private key: Z - RSA public key: Z - DH Private key: Z

Name	Description	Indicator	Inputs	Outputs	Security Functions	SSP Accesses
						- DH Public key: Z - EC Private key: Z - EC Public key: Z - Key Derivation Key: Z - Password or passphrase: Z - PBKDF Derived Key: Z - KBKDF Derived Key: Z - HKDF Derived Key: Z - SSH Derived Key: Z - X9.42 Derived Key: Z - X9.63 Derived Key: Z - KDA OneStep Derived Key:

Name	Description	Indicator	Inputs	Outputs	Security Functions	SSP Accesses
						Z - KDA TwoStep Derive d Key: Z - TLS Derive d Key: Z - Shared Secret: Z - Entropy input: Z - DRBG seed: Z - DRBG internal state (V value, C value): Z - DRBG internal state (V value, Key): Z - Intermediate key generation value: Z

Table 14: Approved Services

The module provides services to operators that assume the available role. All services are described in detail in the API documentation (manual pages). The convention below applies when specifying the access permissions (types) that the service has for each SSP.

- **Generate (G):** The module generates or derives the SSP.
- **Read (R):** The SSP is read from the module (e.g. the SSP is output).
- **Write (W):** The SSP is updated, imported, or written to the module.
- **Execute (E):** The module uses the SSP in performing a cryptographic operation.
- **Zeroize (Z):** The module zeroizes the SSP.
- **N/A:** The module does not access any SSP or key during its operation.

To interact with the module, a calling application must use the EVP API layer provided by OpenSSL. This layer will delegate the request to the FIPS provider, which will in turn perform the requested service. Additionally, this EVP API layer can be used to retrieve the approved service indicator for the module. The `suse_ossl_query_fipsindicator()` function indicates whether an EVP API function is approved. After a cryptographic service was performed by the module, the API context (listed in the left column of the table below) associated with this request can contain a parameter (listed in the left right column of the table below) which represents the approved service indicator.

The exact process to use this function and how to interpret its results is described in the `fips_module_indicators` manual page.

Context	Service Indicator
EVP_CIPHER_CTX	OSSL_CIPHER_PARAM_SUSE_FIPS_INDICATOR
EVP_MAC_CTX	OSSL_MAC_PARAM_SUSE_FIPS_INDICATOR
EVP_KDF_CTX	OSSL_KDF_PARAM_SUSE_FIPS_INDICATOR
EVP_PKEY_CTX	OSSL_SIGNATURE_PARAM_SUSE_FIPS_INDICATOR

Table 15 - Service Indicator Parameters

## 4.4 Non-Approved Services

Name	Description	Algorithms	Role
AES GCM (external IV)	Authenticated Encryption	AES GCM (external IV)	CO
HMAC (< 112-bit keys)	Compute a MAC tag	HMAC (< 112-bit keys)	CO
Key derivation	Derive a key from a key-derivation key or a shared secret	KBKDF, KDA OneStep, KDA TwoStep, HKDF, ANS X9.42 KDF, ANS X9.63 KDF (< 112-bit keys) KDA OneStep, KDA TwoStep (SHAKE128, SHAKE256) ANS X9.42 KDF (SHAKE128, SHAKE256) ANS X9.63 KDF (SHA-1, SHAKE128, SHAKE256) SSH KDF (SHA-512/224, SHA-	CO

Name	Description	Algorithms	Role
		512/256, SHA-3, SHAKE128, SHAKE256) TLS 1.2 KDF (SHA-1, SHA-224, SHA-512/224, SHA-512/256, SHA-3) TLS 1.3 KDF (SHA-1, SHA-224, SHA-512, SHA-512/224, SHA-512/256, SHA-3)	
PBKDF2 (< 112-bit keys)	Derive a key from a password	PBKDF2 (< 8 characters password; < 128 salt length; < 1000 iterations; < 112-bit keys)	CO
Signature generation	Generate a signature	RSA and ECDSA (pre-hashed message) RSA-PSS (invalid salt length: FIPS 186-5, section 5.4, item(g))	CO
Signature verification	Verify a signature	RSA and ECDSA (pre-hashed message) RSA-PSS (invalid salt length: FIPS 186-5, section 5.4, item(g))	CO

Table 16: Non-Approved Services

The table above lists the non-approved services in this module, the algorithms involved and the roles that can request the service. In this table, CO specifies the Crypto Officer role.

## 4.5 External Software/Firmware Loaded

The module does not load external software or firmware.

## 5 Software/Firmware Security

### 5.1 Integrity Techniques

The integrity of the module is verified by comparing a HMAC SHA-256 value calculated at run time with the HMAC SHA-256 value embedded in the fips.so file that was computed at build time. The module performs a KAT for the HMAC SHA-256 algorithm in order to test its proper operation before performing the checksum of the fips.so file.

### 5.2 Initiate on Demand

Integrity tests are performed as part of the pre-operational self-tests, which are executed when the module is initialized. The integrity test may be invoked on-demand by unloading and subsequently re-initializing the module, or by calling the `OSSL_PROVIDER_self_test` function. This will perform (among others) the software integrity test.

## 6 Operational Environment

### 6.1 Operational Environment Type and Requirements

**Type of Operational Environment:** Modifiable

**How Requirements are Satisfied:**

Any SSPs contained within the module are protected by the process isolation and memory separation mechanisms, and only the module has control over these SSPs.

### 6.2 Configuration Settings and Restrictions

The module shall be installed as stated in Section 11 Life-Cycle Assurance. If properly installed, the operating system provides process isolation and memory protection mechanisms that ensure appropriate separation for memory access among the processes on the system. Each process has control over its own data and uncontrolled access to the data of other processes is prevented.

Instrumentation tools like the ptrace system call, gdb and strace, userspace live patching, as well as other tracing mechanisms offered by the Linux environment such as ftrace or systemtap, shall not be used in the operational environment. The use of any of these tools implies that the cryptographic module is running in a non-validated operational environment.

## **7 Physical Security**

The module is comprised of software only and therefore this Section is Not Applicable (N/A).

## **8 Non-Invasive Security**

This module does not implement any non-invasive security mechanism, and therefore this Section is not applicable.

## 9 Sensitive Security Parameters Management

### 9.1 Storage Areas

Storage Area Name	Description	Persistence Type
RAM	Temporary storage for SSPs used by the module as part of service execution. SSPs are stored until they are zeroized by the operator (using a zeroization call or removing power from the module) or zeroized automatically	Dynamic

Table 17: Storage Areas

The module does not perform persistent storage of SSPs. The SSPs are temporarily stored in the RAM in plaintext form.

### 9.2 SSP Input-Output Methods

Name	From	To	Format Type	Distribution Type	Entry Type	SFI or Algorithm
API input parameters	Operator calling application (TOEPP)	Cryptographic module	Plaintext	Manual	Electronic	
API output parameters	Cryptographic module	Operator calling application (TOEPP)	Plaintext	Manual	Electronic	

Table 18: SSP Input-Output Methods

The module only supports SSP entry and output to and from the calling application running on the same operational environment. This corresponds to manual distribution, electronic entry/output (“CM Software to/from App via TOEPP Path”) per FIPS 140-3 IG 9.5.A Table 1.

There is no entry or output of cryptographically protected SSPs.

### 9.3 SSP Zeroization Methods

Zeroization Method	Description	Rationale	Operator Initiation
Free cipher handle	Zeroizes the SSPs contained within the cipher handle.	By calling the appropriate zeroization functions: AES key: <code>EVP_CIPHER_CTX_free</code> and <code>EVP_MAC_CTX_free</code> ; HMAC key: <code>EVP_MAC_CTX_free</code> ; Key-derivation key:	By calling the cipher related zeroization API

Zeroization Method	Description	Rationale	Operator Initiation
		EVP_KDF_CTX_free; Shared secret: EVP_KDF_CTX_free; Password: EVP_KDF_CTX_free; KBKDF Derived Key: EVP_KDF_CTX_free; HKDF Derived Key: EVP_KDF_CTX_free; TLS Derived Key: EVP_KDF_CTX_free; SSH Derived Key: EVP_KDF_CTX_free; X9.63 Derived Key: EVP_KDF_CTX_free; X9.42 Derived Key: EVP_KDF_CTX_free; PBKDF Derived Key: EVP_KDF_CTX_free; KDA OneStep Derived Key: EVP_KDF_CTX_free; KDA TwoStep Derived Key: EVP_KDF_CTX_free; Entropy input: EVP_RAND_CTX_free; DRBG internal state (V value, Key), DRBG internal state (V value, C value): EVP_RAND_CTX_free; DH public & private key: EVP_PKEY_free; EC public & private key: EVP_PKEY_free; RSA public & private key: EVP_PKEY_free	
Automatic	Automatically zeroized by the module when no longer needed	Memory occupied by SSPs is overwritten with zeroes, which renders the SSP values irretrievable.	N/A
Module Reset	De-allocates the volatile memory used to store SSPs	Volatile memory used by the module is overwritten within nanoseconds when power is removed.	By unloading and reloading the module

Table 19: SSP Zeroization Methods

The application that uses the module is responsible for the appropriate zeroization of SSPs. The module provides key allocation and destruction functions, which overwrites the memory occupied by the SSP's information with zeroes before its deallocation.

Memory allocation of SSPs is performed by the OPENSSL\_malloc() API call and the application in use of the module is responsible for the calling of the appropriate zeroization functions from the OpenSSL API. The zeroization functions then overwrite the memory occupied by SSPs and de-allocate the memory with the OPENSSL\_free() call. OPENSSL\_cleanse() should be used to overwrite sensitive data such as private keys.

All data output is inhibited during zeroization.

## 9.4 SSPs

Name	Description	Size - Strength	Type - Category	Generated By	Established By	Used By
AES key	AES key used for encryption, decryption, and computing MAC tags	AES-XTS: 256, 512 bits; Other modes: 128, 192, 256 bits - AES-XTS: 128, 256 bits; Other modes: 128, 192, 256 bits	Symmetric key - CSP			Symmetric Encryption with AES Symmetric Decryption with AES Authenticated Symmetric Encryption Authenticated Symmetric Decryption
HMAC key	HMAC key used for computing MAC tags	112-524288 bits - 112-256 bits	Symmetric key - CSP			Message Authentication Code
Module-generated RSA private key	RSA private key generated by the module	2048-15360 bits - 112-256 bits	Private key - CSP	Key Pair Generation with RSA		Key Pair Generation with RSA
Module-generated RSA public key	RSA public key generated by the module	2048-15360 bits - Key pair generation: 112-256 bits	Public key - PSP	Key Pair Generation with RSA		Key Pair Generation with RSA
RSA private key	RSA private key written to the module	2048-16384 bits - 112-256 bits	Private key - CSP			Signature Generation Shared Secret Computation with RSA Asymmetric Decryption with RSA

<b>Name</b>	<b>Description</b>	<b>Size - Strength</b>	<b>Type - Category</b>	<b>Generated By</b>	<b>Established By</b>	<b>Used By</b>
RSA public key	RSA public key written to the module	Signature verification: 1024-16384 bits; Others: 2048-16384 bits - Signature verification: 80-256 bits; Others: 112-256 bits	Public key - PSP			Signature Verification Shared Secret Computation with RSA Asymmetric Encryption with RSA
Module-generated DH Private key	DH Private key generated by the module	2048-8192 bits - 112-200 bits	Private key - CSP	Key Pair Generation with Safe Primes		Key Pair Generation with Safe Primes
Module-generated DH Public key	DH Public key generated by the module	2048-8192 bits - 112-200 bits	Public key - PSP	Key Pair Generation with Safe Primes		Key Pair Generation with Safe Primes
DH Private key	DH Private key written to the module	2048-8192 bits - 112-200 bits	Private key - CSP			Shared Secret Computation with DH Key Pair Verification with Safe Primes
DH Public key	DH Public key written to the module	2048-8192 bits - 112-200 bits	Public key - PSP			Shared Secret Computation with DH Key Pair Verification with Safe Primes

<b>Name</b>	<b>Description</b>	<b>Size - Strength</b>	<b>Type - Category</b>	<b>Generated By</b>	<b>Established By</b>	<b>Used By</b>
Module-generated EC Private key	EC Private key generated by the module	P-224, P-256, P-384, P-521 bits - 112, 128, 192, 256 bits	Private key - CSP	Key Pair Generation with ECDSA		Key Pair Generation with ECDSA
Module-generated EC Public key	EC Public key generated by the module	P-224, P-256, P-384, P-521 bits - 112, 128, 192, 256 bits	Public key - PSP	Key Pair Generation with ECDSA		Key Pair Generation with ECDSA
EC Private key	EC Private key written the module and used by ECDSA and ECDH	P-224, P-256, P-384, P-521 bits - 112, 128, 192, 256 bits	Private key - CSP			Shared Secret Computation with ECDH Signature Generation Key Pair Verification with ECDSA
EC Public key	EC Public key written the module and used by ECDSA and ECDH	P-224, P-256, P-384, P-521 bits - 112, 128, 192, 256 bits	Public key - PSP			Signature Verification Shared Secret Computation with ECDH Key Pair Verification with ECDSA
Key Derivation Key	Symmetric key used to derive symmetric keys	112-4096 bits - 112-256 bits	Symmetric key - CSP			Key Derivation with KBKDF
KBKDF Derived Key	Symmetric key derived from a	112-4096 bits - 112-256 bits	Symmetric key - CSP	Key Derivation		Key Derivation

Name	Description	Size - Strength	Type - Category	Generated By	Established By	Used By
	key-derivation key			n with KBKDF		with KBKDF
HKDF Derived Key	Symmetric key derived from a shared secret	112-4096 bits - 112-256 bits	Symmetric key - CSP	Key Derivation with HKDF		Key Derivation with HKDF
SSH Derived Key	Symmetric key derived from a shared secret	112-4096 bits - 112-256 bits	Symmetric key - CSP	Key Derivation with SSH KDF		Key Derivation with SSH KDF
X9.63 Derived Key	Symmetric key derived from a shared secret	112-4096 bits - 112-256 bits	Symmetric key - CSP	Key Derivation with X9.63 KDF		Key Derivation with X9.63 KDF
X9.42 Derived Key	Symmetric key derived from a shared secret	112-4096 bits - 112-256 bits	Symmetric key - CSP	Key Derivation with X9.42 KDF		Key Derivation with X9.42 KDF
Password or passphrase	Password or passphrase used by PBKDF to derive symmetric keys	8-128 characters - N/A	Password - CSP			Password-based Key Derivation
PBKDF Derived Key	Key derived from PBKDF password/passphrase during key derivation	112-4096 bits - 112-256 bits	Symmetric key - CSP	Password-based Key Derivation		Password-based Key Derivation
KDA OneStep Derived Key	Symmetric key derived from a shared secret	112-4096 bits - 112-256 bits	Symmetric key - CSP	Key Derivation with KDA OneStep		Key Derivation with KDA OneStep
KDA TwoStep Derived Key	Symmetric key derived from a shared secret	112-4096 bits - 112-256 bits	Symmetric key - CSP	Key Derivation with KDA TwoStep		Key Derivation with KDA TwoStep

Name	Description	Size - Strength	Type - Category	Generated By	Established By	Used By
TLS Derived Key	Derived key used in Transport Layer Security (TLS) network protocol	112-4096 bits - 112-256 bits	Symmetric key - CSP	TLS Key Derivation		
Shared Secret	Shared secret generated by ECDH/DH/RSA shared secret computation	224-8912 bits - 112-256 bits	Shared Secret - CSP		Shared Secret Computation with DH Shared Secret Computation with ECDH Shared Secret Computation with RSA	Key Derivation with KDA OneStep Key Derivation with KDA TwoStep Key Derivation with X9.42 KDF Key Derivation with X9.63 KDF Key Derivation with SSH KDF Key Derivation with HKDF Shared Secret Computation with DH Shared Secret Computation with ECDH Shared Secret Computation with RSA
Entropy input	Entropy input string used to seed the DRBG	128-384 bits - 128-256 bits	Entropy Input - CSP			Random Number Generation

Name	Description	Size - Strength	Type - Category	Generated By	Established By	Used By
	(IG D.L compliant)					
DRBG seed	DRBG seed derived from entropy input (IG D.L compliant)	CTR_DRBG: 256, 320, 384 bits; Hash_DRBG: 440, 888 bits; HMAC_DRBG: 160, 256, 512 bits - CTR_DRBG: 128, 192, 256 bits; HMAC_DRBG, Hash_DRBG: 128, 256 bits	Seed - CSP	Random Number Generation		Random Number Generation
DRBG internal state (V value, C value)	Internal state of the Hash_DRBG (IG D.L compliant)	880, 1776 bits - 128, 256 bits	Internal state - CSP	Random Number Generation		Random Number Generation
DRBG internal state (V value, Key)	Internal state of the CTR_DRBG and HMAC_DRBG (IG D.L compliant)	CTR_DRBG: 256, 320, 384 bits; HMAC_DRBG: 320, 512, 1024 bits - CTR_DRBG: 128, 192, 256 bits; HMAC_DRBG: 128, 256 bits	Internal state - CSP	Random Number Generation		Random Number Generation
Intermediate key	Intermediate key pair generation	112-15360	Intermediate value - CSP	Key Pair Generation with		Key Pair Generation with RSA

Name	Description	Size - Strength	Type - Category	Generated By	Established By	Used By
generation value	value generated during key generation and key derivation services (SP 800-133 Rev. 2 Section 4, 5.1, and 5.2)	bits - 112-256 bits		RSA Key Pair Generation with ECDSA Key Pair Generation with Safe Primes		Key Pair Generation with ECDSA Key Pair Generation with Safe Primes

Table 20: SSP Table 1

Name	Input - Output	Storage	Storage Duration	Zeroization	Related SSPs
AES key	API input parameters	RAM:Plaintext	From service invocation until cipherhandle is freed	Free cipher handle Module Reset	
HMAC key	API input parameters	RAM:Plaintext	From service invocation until cipherhandle is freed	Free cipher handle Module Reset	
Module-generated RSA private key	API output parameters	RAM:Plaintext	From service invocation until cipherhandle is freed	Free cipher handle Module Reset	Module-generated RSA public key:Paired With Intermediate key generation value:Generated From
Module-generated RSA public key	API output parameters	RAM:Plaintext	From service invocation until cipherhandle is freed	Free cipher handle Module Reset	Module-generated RSA private key:Paired With Intermediate key generation value:Generated From

<b>Name</b>	<b>Input - Output</b>	<b>Storage</b>	<b>Storage Duration</b>	<b>Zeroization</b>	<b>Related SSPs</b>
RSA private key	API input parameters	RAM:Plaintext	From service invocation until cipherhandle is freed	Free cipher handle Module Reset	RSA public key:Paired With
RSA public key	API input parameters	RAM:Plaintext	From service invocation until cipherhandle is freed	Free cipher handle Module Reset	RSA private key:Paired With
Module-generated DH Private key	API output parameters	RAM:Plaintext	From service invocation until cipherhandle is freed	Free cipher handle Module Reset	Module-generated DH Public key:Paired With Intermediate key generation value:Generated From
Module-generated DH Public key	API output parameters	RAM:Plaintext	From service invocation until cipherhandle is freed	Free cipher handle Module Reset	Module-generated DH Private key:Paired With Intermediate key generation value:Generated From
DH Private key	API input parameters	RAM:Plaintext	From service invocation until cipherhandle is freed	Free cipher handle Module Reset	DH Public key:Paired With
DH Public key	API input parameters	RAM:Plaintext	From service invocation until cipherhandle is freed	Free cipher handle Module Reset	DH Private key:Paired With
Module-generated EC Private key	API output parameters	RAM:Plaintext	From service invocation until	Free cipher handle Module Reset	Module-generated EC Public key:Paired With Intermediate key generation

Name	Input - Output	Storage	Storage Duration	Zeroization	Related SSPs
			cipherhandle is freed		value:Generated From
Module-generated EC Public key	API output parameters	RAM:Plaintext	From service invocation until cipherhandle is freed	Free cipher handle Module Reset	Module-generated EC private key:Paired With Intermediate key generation value:Generated From
EC Private key	API input parameters	RAM:Plaintext	From service invocation until cipherhandle is freed	Free cipher handle Module Reset	EC Public key:Paired With
EC Public key	API input parameters	RAM:Plaintext	From service invocation until cipherhandle is freed	Free cipher handle Module Reset	EC private key:Paired With
Key Derivation Key	API input parameters	RAM:Plaintext	From service invocation until cipherhandle is freed	Free cipher handle Module Reset	KBKDF Derived Key:Derives
KBKDF Derived Key	API output parameters	RAM:Plaintext	From service invocation until cipherhandle is freed	Free cipher handle Module Reset	Key-derivation key:Derived From
HKDF Derived Key	API output parameters	RAM:Plaintext	From service invocation until cipherhandle is freed	Free cipher handle Module Reset	Shared secret:Derived From
SSH Derived Key	API output parameters	RAM:Plaintext	From service invocation until	Free cipher handle Module Reset	Shared secret:Derived From

Name	Input - Output	Storage	Storage Duration	Zeroization	Related SSPs
			cipherhandle is freed		
X9.63 Derived Key	API output parameters	RAM:Plaintext	From service invocation until cipherhandle is freed	Free cipher handle Module Reset	Shared secret:Derived From
X9.42 Derived Key	API output parameters	RAM:Plaintext	From service invocation until cipherhandle is freed	Free cipher handle Module Reset	Shared secret:Derived From
Password or passphrase	API input parameters	RAM:Plaintext	From service invocation until cipherhandle is freed	Free cipher handle Module Reset	PBKDF Derived Key:Derives
PBKDF Derived Key	API output parameters	RAM:Plaintext	From service invocation until cipherhandle is freed	Free cipher handle Module Reset	Password or passphrase:Derived From
KDA OneStep Derived Key	API output parameters	RAM:Plaintext	From service invocation until cipherhandle is freed	Free cipher handle Module Reset	Shared secret:Derived From
KDA TwoStep Derived Key	API output parameters	RAM:Plaintext	From service invocation until cipherhandle is freed	Free cipher handle Module Reset	Shared secret:Derived From
TLS Derived Key	API output parameters	RAM:Plaintext	From service invocation until	Free cipher handle Module Reset	Shared Secret:Derived From

Name	Input - Output	Storage	Storage Duration	Zeroization	Related SSPs
			cipherhandle is freed		
Shared Secret	API input parameters API output parameters	RAM:Plaintext	From service invocation until cipherhandle is freed	Free cipherhandle Module Reset	DH private key:Established By DH public key:Established By EC private key:Established By EC public key:Established By HKDF Derived Key:Derives KDA OneStep Derived Key:Derives KDA TwoStep Derived Key:Derives TLS Derived Key:Derives SSH Derived Key:Derives X9.63 Derived Key:Derives X9.42 Derived Key:Derives RSA private key:Established By RSA public key:Established By
Entropy input		RAM:Plaintext	From generation until DRBG seed is created	Automatic Module Reset	DRBG seed:Derives
DRBG seed		RAM:Plaintext	While the DRBG is instantiated	Automatic Module Reset	Entropy input:Derived From DRBG internal state (V value, C value):Generates DRBG internal state (V value, Key):Generates

Name	Input - Output	Storage	Storage Duration	Zeroization	Related SSPs
DRBG internal state (V value, C value)		RAM:Plaintext	From DRBG instantiation until DRBG termination	Free cipher handle Module Reset	DRBG seed:Generated From
DRBG internal state (V value, Key)		RAM:Plaintext	From DRBG instantiation until DRBG termination	Free cipher handle Module Reset	DRBG seed:Generated From
Intermediate key generation value		RAM:Plaintext	From service invocation until cipherhandle is freed	Automatic	DH private key:Generates DH public key:Generates EC private key:Generates EC public key:Generates RSA private key:Generates RSA public key:Generates

Table 21: SSP Table 2

## 9.5 Transitions

The SHA-1 algorithm as implemented by the module will be non-approved for all purposes, starting January 1, 2031.

## 10 Self-Tests

### 10.1 Pre-Operational Self-Tests

Algorithm or Test	Test Properties	Test Method	Test Type	Indicator	Details
HMAC-SHA2-256 (A5868)	256-bits key	Message authentication	SW/FW Integrity	Module becomes operational and services are available for use	Integrity test of the shared library component of the module. Verified by comparing an HMAC SHA-256 value calculated at run time with the HMAC SHA-256 value embedded in the fips.so file that was computed at build time.
HMAC-SHA2-256 (A5864)	256-bits key	Message authentication	SW/FW Integrity	Module becomes operational and services are available for use	Integrity test of the shared library component of the module. Verified by comparing an HMAC SHA-256 value calculated at run time with the HMAC SHA-256 value embedded in the fips.so file that was computed at build time.
HMAC-SHA2-256 (A5876)	256-bits key	Message authentication	SW/FW Integrity	Module becomes operational and services are available for use	Integrity test of the shared library component of the module. Verified by comparing an HMAC SHA-256 value calculated at run time with the HMAC SHA-256 value embedded in the fips.so file that was computed at build time.
HMAC-SHA2-256 (A5877)	256-bits key	Message authentication	SW/FW Integrity	Module becomes operational	Integrity test of the shared library component of the

Algorithm or Test	Test Properties	Test Method	Test Type	Indicator	Details
				and services are available for use	module. Verified by comparing an HMAC SHA-256 value calculated at run time with the HMAC SHA-256 value embedded in the fips.so file that was computed at build time.
HMAC-SHA2-256 (A5878)	256-bits key	Message authentication	SW/FW Integrity	Module becomes operational and services are available for use	Integrity test of the shared library component of the module. Verified by comparing an HMAC SHA-256 value calculated at run time with the HMAC SHA-256 value embedded in the fips.so file that was computed at build time.
HMAC-SHA2-256 (A5879)	256-bits key	Message authentication	SW/FW Integrity	Module becomes operational and services are available for use	Integrity test of the shared library component of the module. Verified by comparing an HMAC SHA-256 value calculated at run time with the HMAC SHA-256 value embedded in the fips.so file that was computed at build time.
HMAC-SHA2-256 (A5883)	256-bits key	Message authentication	SW/FW Integrity	Module becomes operational and services are available for use	Integrity test of the shared library component of the module. Verified by comparing an HMAC SHA-256 value calculated at run time with the HMAC SHA-256 value embedded in the fips.so file that

Algorithm or Test	Test Properties	Test Method	Test Type	Indicator	Details
					was computed at build time.
HMAC-SHA2-256 (A5889)	256-bits key Message	Message authentication	SW/FW Integrity	Module becomes operational and services are available for use	Integrity test of the shared library component of the module. Verified by comparing an HMAC SHA-256 value calculated at run time with the HMAC SHA-256 value embedded in the fips.so file that was computed at build time.

Table 22: Pre-Operational Self-Tests

The pre-operational software integrity tests are performed automatically when the module is initialized, before the module transitions into the operational state. While the module is executing the self-tests, services are not available, and data output (via the data output interface) is inhibited until the tests are successfully completed. The module transitions to the operational state only after the pre-operational self-tests are passed successfully.

Prior the first use, a CAST is executed for the algorithms used in the Pre-operational Self-Tests.

## 10.2 Conditional Self-Tests

Algorithm or Test	Test Properties	Test Method	Test Type	Indicator	Details	Conditions
SHA-1 (A5868)	24-bit message	KAT	CAST	Module becomes operational	Message digest	Test runs at power-on before the integrity test
SHA-1 (A5876)	24-bit message	KAT	CAST	Module becomes operational	Message digest	Test runs at power-on before the integrity test
SHA-1 (A5877)	24-bit message	KAT	CAST	Module becomes operational	Message digest	Test runs at power-on before the integrity test

<b>Algorithm or Test</b>	<b>Test Properties</b>	<b>Test Method</b>	<b>Test Type</b>	<b>Indicator</b>	<b>Details</b>	<b>Conditions</b>
SHA-1 (A5878)	24-bit message	KAT	CAST	Module becomes operational	Message digest	Test runs at power-on before the integrity test
SHA-1 (A5879)	24-bit message	KAT	CAST	Module becomes operational	Message digest	Test runs at power-on before the integrity test
SHA-1 (A5883)	24-bit message	KAT	CAST	Module becomes operational	Message digest	Test runs at power-on before the integrity test
SHA-1 (A5889)	24-bit message	KAT	CAST	Module becomes operational	Message digest	Test runs at power-on before the integrity test
SHA2-512 (A5868)	24-bit message	KAT	CAST	Module becomes operational	Message digest	Test runs at power-on before the integrity test
SHA2-512 (A5876)	24-bit message	KAT	CAST	Module becomes operational	Message digest	Test runs at power-on before the integrity test
SHA2-512 (A5877)	24-bit message	KAT	CAST	Module becomes operational	Message digest	Test runs at power-on before the integrity test
SHA2-512 (A5878)	24-bit message	KAT	CAST	Module becomes operational	Message digest	Test runs at power-on before the integrity test

<b>Algorithm or Test</b>	<b>Test Properties</b>	<b>Test Method</b>	<b>Test Type</b>	<b>Indicator</b>	<b>Details</b>	<b>Conditions</b>
SHA2-512 (A5879)	24-bit message	KAT	CAST	Module becomes operational	Message digest	Test runs at power-on before the integrity test
SHA2-512 (A5883)	24-bit message	KAT	CAST	Module becomes operational	Message digest	Test runs at power-on before the integrity test
SHA2-512 (A5889)	24-bit message	KAT	CAST	Module becomes operational	Message digest	Test runs at power-on before the integrity test
HMAC-SHA2-256 (A5864)	256-bit key	KAT	CAST	Module becomes operational	Message digest	Test runs at power-on before the integrity test
HMAC-SHA2-256 (A5868)	256-bit key	KAT	CAST	Module becomes operational	Message digest	Test runs at power-on before the integrity test
HMAC-SHA2-256 (A5876)	256-bit key	KAT	CAST	Module becomes operational	Message digest	Test runs at power-on before the integrity test
HMAC-SHA2-256 (A5877)	256-bit key	KAT	CAST	Module becomes operational	Message digest	Test runs at power-on before the integrity test
HMAC-SHA2-256 (A5878)	256-bit key	KAT	CAST	Module becomes operational	Message digest	Test runs at power-on before the integrity test

Algorithm or Test	Test Properties	Test Method	Test Type	Indicator	Details	Conditions
HMAC-SHA2-256 (A5879)	256-bit key	KAT	CAST	Module becomes operational	Message digest	Test runs at power-on before the integrity test
HMAC-SHA2-256 (A5883)	256-bit key	KAT	CAST	Module becomes operational	Message digest	Test runs at power-on before the integrity test
HMAC-SHA2-256 (A5889)	256-bit key	KAT	CAST	Module becomes operational	Message digest	Test runs at power-on before the integrity test
SHA3-256 (A5869)	32-bit message	KAT	CAST	Module becomes operational	Message digest	Test runs at power-on before the integrity test
SHA3-256 (A5885)	32-bit message	KAT	CAST	Module becomes operational	Message digest	Test runs at power-on before the integrity test
AES-GCM (A5870)	256-bit key and 96-bit IV, encrypt and decrypt	KAT	CAST	Module becomes operational	Symmetric operation	Test runs at power-on before the integrity test
AES-GCM (A5871)	256-bit key and 96-bit IV, encrypt and decrypt	KAT	CAST	Module becomes operational	Symmetric operation	Test runs at power-on before the integrity test
AES-GCM (A5872)	256-bit key and 96-bit IV, encrypt and decrypt	KAT	CAST	Module becomes operational	Symmetric operation	Test runs at power-on before the integrity test

<b>Algorithm or Test</b>	<b>Test Properties</b>	<b>Test Method</b>	<b>Test Type</b>	<b>Indicator</b>	<b>Details</b>	<b>Conditions</b>
AES-GCM (A5873)	256-bit key and 96-bit IV, encrypt and decrypt	KAT	CAST	Module becomes operational	Symmetric operation	Test runs at power-on before the integrity test
AES-GCM (A5874)	256-bit key and 96-bit IV, encrypt and decrypt	KAT	CAST	Module becomes operational	Symmetric operation	Test runs at power-on before the integrity test
AES-GCM (A5875)	256-bit key and 96-bit IV, encrypt and decrypt	KAT	CAST	Module becomes operational	Symmetric operation	Test runs at power-on before the integrity test
AES-GCM (A5880)	256-bit key and 96-bit IV, encrypt and decrypt	KAT	CAST	Module becomes operational	Symmetric operation	Test runs at power-on before the integrity test
AES-GCM (A5881)	256-bit key and 96-bit IV, encrypt and decrypt	KAT	CAST	Module becomes operational	Symmetric operation	Test runs at power-on before the integrity test
AES-GCM (A5882)	256-bit key and 96-bit IV, encrypt and decrypt	KAT	CAST	Module becomes operational	Symmetric operation	Test runs at power-on before the integrity test
AES-GCM (A5886)	256-bit key and 96-bit IV, encrypt and decrypt	KAT	CAST	Module becomes operational	Symmetric operation	Test runs at power-on before the integrity test
AES-GCM (A5887)	256-bit key and 96-bit IV, encrypt and decrypt	KAT	CAST	Module becomes operational	Symmetric operation	Test runs at power-on before the integrity test

<b>Algorithm or Test</b>	<b>Test Properties</b>	<b>Test Method</b>	<b>Test Type</b>	<b>Indicator</b>	<b>Details</b>	<b>Conditions</b>
AES-GCM (A5888)	256-bit key and 96-bit IV, encrypt and decrypt	KAT	CAST	Module becomes operational	Symmetric operation	Test runs at power-on before the integrity test
AES-GCM (A5903)	256-bit key and 96-bit IV, encrypt and decrypt	KAT	CAST	Module becomes operational	Symmetric operation	Test runs at power-on before the integrity test
AES-GCM (A5904)	256-bit key and 96-bit IV, encrypt and decrypt	KAT	CAST	Module becomes operational	Symmetric operation	Test runs at power-on before the integrity test
AES-GCM (A5905)	256-bit key and 96-bit IV, encrypt and decrypt	KAT	CAST	Module becomes operational	Symmetric operation	Test runs at power-on before the integrity test
AES-ECB (A5398)	128-bit key, decrypt	KAT	CAST	Module becomes operational	Symmetric operation	Test runs at power-on before the integrity test
AES-ECB (A5399)	128-bit key, decrypt	KAT	CAST	Module becomes operational	Symmetric operation	Test runs at power-on before the integrity test
AES-ECB (A5400)	128-bit key, decrypt	KAT	CAST	Module becomes operational	Symmetric operation	Test runs at power-on before the integrity test
AES-ECB (A5401)	128-bit key, decrypt	KAT	CAST	Module becomes operational	Symmetric operation	Test runs at power-on before the integrity test

Algorithm or Test	Test Properties	Test Method	Test Type	Indicator	Details	Conditions
AES-ECB (A5402)	128-bit key, decrypt	KAT	CAST	Module becomes operational	Symmetric operation	Test runs at power-on before the integrity test
AES-ECB (A5403)	128-bit key, decrypt	KAT	CAST	Module becomes operational	Symmetric operation	Test runs at power-on before the integrity test
AES-ECB (A5658)	128-bit key, decrypt	KAT	CAST	Module becomes operational	Symmetric operation	Test runs at power-on before the integrity test
AES-ECB (A5884)	128-bit key, decrypt	KAT	CAST	Module becomes operational	Symmetric operation	Test runs at power-on before the integrity test
AES-ECB (A5893)	128-bit key, decrypt	KAT	CAST	Module becomes operational	Symmetric operation	Test runs at power-on before the integrity test
AES-ECB (A5894)	128-bit key, decrypt	KAT	CAST	Module becomes operational	Symmetric operation	Test runs at power-on before the integrity test
AES-ECB (A5895)	128-bit key, decrypt	KAT	CAST	Module becomes operational	Symmetric operation	Test runs at power-on before the integrity test
AES-ECB (A5896)	128-bit key, decrypt	KAT	CAST	Module becomes operational	Symmetric operation	Test runs at power-on before the integrity test

Algorithm or Test	Test Properties	Test Method	Test Type	Indicator	Details	Conditions
AES-ECB (A5900)	128-bit key, decrypt	KAT	CAST	Module becomes operational	Symmetric operation	Test runs at power-on before the integrity test
RSA SigGen (FIPS186-5) (A5868)	PKCS#1 v1.5 with SHA-256 and 2048-bit key	KAT	CAST	Module becomes operational	Digital signature generation	Test runs at power-on before the integrity test
RSA SigGen (FIPS186-5) (A5869)	PKCS#1 v1.5 with SHA-256 and 2048-bit key	KAT	CAST	Module becomes operational	Digital signature generation	Test runs at power-on before the integrity test
RSA SigGen (FIPS186-5) (A5876)	PKCS#1 v1.5 with SHA-256 and 2048-bit key	KAT	CAST	Module becomes operational	Digital signature generation	Test runs at power-on before the integrity test
RSA SigGen (FIPS186-5) (A5877)	PKCS#1 v1.5 with SHA-256 and 2048-bit key	KAT	CAST	Module becomes operational	Digital signature generation	Test runs at power-on before the integrity test
RSA SigGen (FIPS186-5) (A5878)	PKCS#1 v1.5 with SHA-256 and 2048-bit key	KAT	CAST	Module becomes operational	Digital signature generation	Test runs at power-on before the integrity test
RSA SigGen (FIPS186-5) (A5879)	PKCS#1 v1.5 with SHA-256 and 2048-bit key	KAT	CAST	Module becomes operational	Digital signature generation	Test runs at power-on before the integrity test
RSA SigGen (FIPS186-5) (A5883)	PKCS#1 v1.5 with SHA-256 and 2048-bit key	KAT	CAST	Module becomes operational	Digital signature generation	Test runs at power-on before the integrity test

Algorithm or Test	Test Properties	Test Method	Test Type	Indicator	Details	Conditions
RSA SigGen (FIPS186-5) (A5885)	PKCS#1 v1.5 with SHA-256 and 2048-bit key	KAT	CAST	Module becomes operational	Digital signature generation	Test runs at power-on before the integrity test
RSA SigGen (FIPS186-5) (A5889)	PKCS#1 v1.5 with SHA-256 and 2048-bit key	KAT	CAST	Module becomes operational	Digital signature generation	Test runs at power-on before the integrity test
RSA SigVer (FIPS186-5) (A5868)	PKCS#1 v1.5 with SHA-256 and 2048-bit key	KAT	CAST	Module becomes operational	Digital signature verification	Test runs at power-on before the integrity test
RSA SigVer (FIPS186-5) (A5869)	PKCS#1 v1.5 with SHA-256 and 2048-bit key	KAT	CAST	Module becomes operational	Digital signature verification	Test runs at power-on before the integrity test
RSA SigVer (FIPS186-5) (A5876)	PKCS#1 v1.5 with SHA-256 and 2048-bit key	KAT	CAST	Module becomes operational	Digital signature verification	Test runs at power-on before the integrity test
RSA SigVer (FIPS186-5) (A5877)	PKCS#1 v1.5 with SHA-256 and 2048-bit key	KAT	CAST	Module becomes operational	Digital signature verification	Test runs at power-on before the integrity test
RSA SigVer (FIPS186-5) (A5878)	PKCS#1 v1.5 with SHA-256 and 2048-bit key	KAT	CAST	Module becomes operational	Digital signature verification	Test runs at power-on before the integrity test
RSA SigVer (FIPS186-5) (A5879)	PKCS#1 v1.5 with SHA-256 and 2048-bit key	KAT	CAST	Module becomes operational	Digital signature verification	Test runs at power-on before the integrity test

Algorithm or Test	Test Properties	Test Method	Test Type	Indicator	Details	Conditions
RSA SigVer (FIPS186-5) (A5883)	PKCS#1 v1.5 with SHA-256 and 2048-bit key	KAT	CAST	Module becomes operational	Digital signature verification	Test runs at power-on before the integrity test
RSA SigVer (FIPS186-5) (A5885)	PKCS#1 v1.5 with SHA-256 and 2048-bit key	KAT	CAST	Module becomes operational	Digital signature verification	Test runs at power-on before the integrity test
RSA SigVer (FIPS186-5) (A5889)	PKCS#1 v1.5 with SHA-256 and 2048-bit key	KAT	CAST	Module becomes operational	Digital signature verification	Test runs at power-on before the integrity test
ECDSA SigGen (FIPS186-5) (A5868)	SHA-256 and P-224, P-256, P-384, and P-521	KAT	CAST	Module becomes operational	Digital signature generation	Test runs at power-on before the integrity test
ECDSA SigGen (FIPS186-5) (A5869)	SHA-256 and P-224, P-256, P-384, and P-521	KAT	CAST	Module becomes operational	Digital signature generation	Test runs at power-on before the integrity test
ECDSA SigGen (FIPS186-5) (A5876)	SHA-256 and P-224, P-256, P-384, and P-521	KAT	CAST	Module becomes operational	Digital signature generation	Test runs at power-on before the integrity test
ECDSA SigGen (FIPS186-5) (A5877)	SHA-256 and P-224, P-256, P-384, and P-521	KAT	CAST	Module becomes operational	Digital signature generation	Test runs at power-on before the integrity test
ECDSA SigGen (FIPS186-5) (A5878)	SHA-256 and P-224, P-256, P-384, and P-521	KAT	CAST	Module becomes operational	Digital signature generation	Test runs at power-on before the integrity test

Algorithm or Test	Test Properties	Test Method	Test Type	Indicator	Details	Conditions
ECDSA SigGen (FIPS186-5) (A5879)	SHA-256 and P-224, P-256, P-384, and P-521	KAT	CAST	Module becomes operational	Digital signature generation	Test runs at power-on before the integrity test
ECDSA SigGen (FIPS186-5) (A5883)	SHA-256 and P-224, P-256, P-384, and P-521	KAT	CAST	Module becomes operational	Digital signature generation	Test runs at power-on before the integrity test
ECDSA SigGen (FIPS186-5) (A5885)	SHA-256 and P-224, P-256, P-384, and P-521	KAT	CAST	Module becomes operational	Digital signature generation	Test runs at power-on before the integrity test
ECDSA SigGen (FIPS186-5) (A5889)	SHA-256 and P-224, P-256, P-384, and P-521	KAT	CAST	Module becomes operational	Digital signature generation	Test runs at power-on before the integrity test
ECDSA SigVer (FIPS186-5) (A5868)	SHA-256 and P-224, P-256, P-384, and P-521	KAT	CAST	Module becomes operational	Digital signature verification	Test runs at power-on before the integrity test
ECDSA SigVer (FIPS186-5) (A5869)	SHA-256 and P-224, P-256, P-384, and P-521	KAT	CAST	Module becomes operational	Digital signature verification	Test runs at power-on before the integrity test
ECDSA SigVer (FIPS186-5) (A5876)	SHA-256 and P-224, P-256, P-384, and P-521	KAT	CAST	Module becomes operational	Digital signature verification	Test runs at power-on before the integrity test
ECDSA SigVer (FIPS186-5) (A5877)	SHA-256 and P-224, P-256, P-384, and P-521	KAT	CAST	Module becomes operational	Digital signature verification	Test runs at power-on before the integrity test

Algorithm or Test	Test Properties	Test Method	Test Type	Indicator	Details	Conditions
ECDSA SigVer (FIPS186-5) (A5878)	SHA-256 and P-224, P-256, P-384, and P-521	KAT	CAST	Module becomes operational	Digital signature verification	Test runs at power-on before the integrity test
ECDSA SigVer (FIPS186-5) (A5879)	SHA-256 and P-224, P-256, P-384, and P-521	KAT	CAST	Module becomes operational	Digital signature verification	Test runs at power-on before the integrity test
ECDSA SigVer (FIPS186-5) (A5883)	SHA-256 and P-224, P-256, P-384, and P-521	KAT	CAST	Module becomes operational	Digital signature verification	Test runs at power-on before the integrity test
ECDSA SigVer (FIPS186-5) (A5885)	SHA-256 and P-224, P-256, P-384, and P-521	KAT	CAST	Module becomes operational	Digital signature verification	Test runs at power-on before the integrity test
ECDSA SigVer (FIPS186-5) (A5889)	SHA-256 and P-224, P-256, P-384, and P-521	KAT	CAST	Module becomes operational	Digital signature verification	Test runs at power-on before the integrity test
KDF SP800-108 (A5899)	HMAC-SHA2-256 in counter mode and 128-bit input key	KAT	CAST	Module becomes operational	Key Derivation with KBKDF	Test runs at power-on before the integrity test
KDA OneStep SP800-56Cr2 (A5897)	SHA2-224 and 448-bit input secret	KAT	CAST	Module becomes operational	Shared secret key derivation	Test runs at power-on before the integrity test
KDA TwoStep SP800-56Cr2 (A5897)	SHA2-224 and 448-bit input secret	KAT	CAST	Module becomes operational	Shared secret key derivation	Test runs at power-on before the integrity test

Algorithm or Test	Test Properties	Test Method	Test Type	Indicator	Details	Conditions
KDA HKDF SP800-56Cr2 (A5863)	SHA2-256 and 48-bit secret	KAT	CAST	Module becomes operational	Shared secret key derivation	Test runs at power-on before the integrity test
KDF ANS 9.42 (A5868)	AES-128 KW and SHA-1 and 160-bit input secret	KAT	CAST	Module becomes operational	ANS X9.42 key derivation	Test runs at power-on before the integrity test
KDF ANS 9.42 (A5869)	AES-128 KW and SHA-1 and 160-bit input secret	KAT	CAST	Module becomes operational	ANS X9.42 key derivation	Test runs at power-on before the integrity test
KDF ANS 9.42 (A5876)	AES-128 KW and SHA-1 and 160-bit input secret	KAT	CAST	Module becomes operational	ANS X9.42 key derivation	Test runs at power-on before the integrity test
KDF ANS 9.42 (A5877)	AES-128 KW and SHA-1 and 160-bit input secret	KAT	CAST	Module becomes operational	ANS X9.42 key derivation	Test runs at power-on before the integrity test
KDF ANS 9.42 (A5878)	AES-128 KW and SHA-1 and 160-bit input secret	KAT	CAST	Module becomes operational	ANS X9.42 key derivation	Test runs at power-on before the integrity test
KDF ANS 9.42 (A5879)	AES-128 KW and SHA-1 and 160-bit input secret	KAT	CAST	Module becomes operational	ANS X9.42 key derivation	Test runs at power-on before the integrity test
KDF ANS 9.42 (A5883)	AES-128 KW and SHA-1 and 160-bit input secret	KAT	CAST	Module becomes operational	ANS X9.42 key derivation	Test runs at power-on before the integrity test

<b>Algorithm or Test</b>	<b>Test Properties</b>	<b>Test Method</b>	<b>Test Type</b>	<b>Indicator</b>	<b>Details</b>	<b>Conditions</b>
KDF ANS 9.42 (A5885)	AES-128 KW and SHA-1 and 160-bit input secret	KAT	CAST	Module becomes operational	ANS X9.42 key derivation	Test runs at power-on before the integrity test
KDF ANS 9.42 (A5889)	AES-128 KW and SHA-1 and 160-bit input secret	KAT	CAST	Module becomes operational	ANS X9.42 key derivation	Test runs at power-on before the integrity test
KDF ANS 9.63 (A5868)	SHA2-256 and 192-bit input secret	KAT	CAST	Module becomes operational	ANS X9.63 key derivation	Test runs at power-on before the integrity test
KDF ANS 9.63 (A5869)	SHA2-256 and 192-bit input secret	KAT	CAST	Module becomes operational	ANS X9.63 key derivation	Test runs at power-on before the integrity test
KDF ANS 9.63 (A5876)	SHA2-256 and 192-bit input secret	KAT	CAST	Module becomes operational	ANS X9.63 key derivation	Test runs at power-on before the integrity test
KDF ANS 9.63 (A5877)	SHA2-256 and 192-bit input secret	KAT	CAST	Module becomes operational	ANS X9.63 key derivation	Test runs at power-on before the integrity test
KDF ANS 9.63 (A5878)	SHA2-256 and 192-bit input secret	KAT	CAST	Module becomes operational	ANS X9.63 key derivation	Test runs at power-on before the integrity test
KDF ANS 9.63 (A5879)	SHA2-256 and 192-bit input secret	KAT	CAST	Module becomes operational	ANS X9.63 key derivation	Test runs at power-on before the integrity test

<b>Algorithm or Test</b>	<b>Test Properties</b>	<b>Test Method</b>	<b>Test Type</b>	<b>Indicator</b>	<b>Details</b>	<b>Conditions</b>
KDF ANS 9.63 (A5883)	SHA2-256 and 192-bit input secret	KAT	CAST	Module becomes operational	ANS X9.63 key derivation	Test runs at power-on before the integrity test
KDF ANS 9.63 (A5885)	SHA2-256 and 192-bit input secret	KAT	CAST	Module becomes operational	ANS X9.63 key derivation	Test runs at power-on before the integrity test
KDF ANS 9.63 (A5889)	SHA2-256 and 192-bit input secret	KAT	CAST	Module becomes operational	ANS X9.63 key derivation	Test runs at power-on before the integrity test
KDF SSH (A5884)	SHA-1 and 1056-bit input secret	KAT	CAST	Module becomes operational	SSH KDF key derivation	Test runs at power-on before the integrity test
KDF SSH (A5893)	SHA-1 and 1056-bit input secret	KAT	CAST	Module becomes operational	SSH KDF key derivation	Test runs at power-on before the integrity test
KDF SSH (A5894)	SHA-1 and 1056-bit input secret	KAT	CAST	Module becomes operational	SSH KDF key derivation	Test runs at power-on before the integrity test
KDF SSH (A5895)	SHA-1 and 1056-bit input secret	KAT	CAST	Module becomes operational	SSH KDF key derivation	Test runs at power-on before the integrity test
KDF SSH (A5896)	SHA-1 and 1056-bit input secret	KAT	CAST	Module becomes operational	SSH KDF key derivation	Test runs at power-on before the integrity test

Algorithm or Test	Test Properties	Test Method	Test Type	Indicator	Details	Conditions
KDF SSH (A5900)	SHA-1 and 1056-bit input secret	KAT	CAST	Module becomes operational	SSH KDF key derivation	Test runs at power-on before the integrity test
TLS v1.2 KDF RFC7627 (A5868)	SHA2-256 and 384-bit input secret	KAT	CAST	Module becomes operational	TLS v1.2 KDF key derivation	Test runs at power-on before the integrity test
TLS v1.2 KDF RFC7627 (A5876)	SHA2-256 and 384-bit input secret	KAT	CAST	Module becomes operational	TLS v1.2 KDF key derivation	Test runs at power-on before the integrity test
TLS v1.2 KDF RFC7627 (A5877)	SHA2-256 and 384-bit input secret	KAT	CAST	Module becomes operational	TLS v1.2 KDF key derivation	Test runs at power-on before the integrity test
TLS v1.2 KDF RFC7627 (A5878)	SHA2-256 and 384-bit input secret	KAT	CAST	Module becomes operational	TLS v1.2 KDF key derivation	Test runs at power-on before the integrity test
TLS v1.2 KDF RFC7627 (A5879)	SHA2-256 and 384-bit input secret	KAT	CAST	Module becomes operational	TLS v1.2 KDF key derivation	Test runs at power-on before the integrity test
TLS v1.2 KDF RFC7627 (A5883)	SHA2-256 and 384-bit input secret	KAT	CAST	Module becomes operational	TLS v1.2 KDF key derivation	Test runs at power-on before the integrity test
TLS v1.2 KDF RFC7627 (A5889)	SHA2-256 and 384-bit input secret	KAT	CAST	Module becomes operational	TLS v1.2 KDF key derivation	Test runs at power-on before the integrity test

Algorithm or Test	Test Properties	Test Method	Test Type	Indicator	Details	Conditions
TLS v1.3 KDF (A5863)	SHA2-256, extract and expand modes	KAT	CAST	Module becomes operational	TLS v1.3 KDF key derivation	Test runs at power-on before the integrity test
PBKDF (A5868)	SHA2-256 with 24 characters password, 288-bit salt, 4096 iterations	KAT	CAST	Module becomes operational	Password-based Key Derivation	Test runs at power-on before the integrity test
PBKDF (A5869)	SHA2-256 with 24 characters password, 288-bit salt, 4096 iterations	KAT	CAST	Module becomes operational	Password-based Key Derivation	Test runs at power-on before the integrity test
PBKDF (A5876)	SHA2-256 with 24 characters password, 288-bit salt, 4096 iterations	KAT	CAST	Module becomes operational	Password-based Key Derivation	Test runs at power-on before the integrity test
PBKDF (A5877)	SHA2-256 with 24 characters password, 288-bit salt, 4096 iterations	KAT	CAST	Module becomes operational	Password-based Key Derivation	Test runs at power-on before the integrity test
PBKDF (A5878)	SHA2-256 with 24 characters password, 288-bit salt, 4096 iterations	KAT	CAST	Module becomes operational	Password-based Key Derivation	Test runs at power-on before the integrity test
PBKDF (A5879)	SHA2-256 with 24 characters password,	KAT	CAST	Module becomes operational	Password-based Key Derivation	Test runs at power-on before the

Algorithm or Test	Test Properties	Test Method	Test Type	Indicator	Details	Conditions
	288-bit salt, 4096 iterations					integrity test
PBKDF (A5883)	SHA2-256 with 24 characters password, 288-bit salt, 4096 iterations	KAT	CAST	Module becomes operational	Password-based Key Derivation	Test runs at power-on before the integrity test
PBKDF (A5885)	SHA2-256 with 24 characters password, 288-bit salt, 4096 iterations	KAT	CAST	Module becomes operational	Password-based Key Derivation	Test runs at power-on before the integrity test
PBKDF (A5889)	SHA2-256 with 24 characters password, 288-bit salt, 4096 iterations	KAT	CAST	Module becomes operational	Password-based Key Derivation	Test runs at power-on before the integrity test
Counter DRBG (A5397)	AES-128 with derivation function and prediction resistance	KAT	CAST	Module becomes operational	Instantiate; Generate; Reseed (compliant to SP 800-90A Rev. 1 Section 11.3)	Test runs at power-on before the integrity test
Hash DRBG (A5397)	SHA2-256 and prediction resistance	KAT	CAST	Module becomes operational	Instantiate; Generate; Reseed (compliant to SP 800-90A Rev. 1 Section 11.3)	Test runs at power-on before the integrity test
HMAC DRBG (A5397)	HMAC-SHA-1 and prediction resistance	KAT	CAST	Module becomes operational	Instantiate; Generate; Reseed (compliant to SP 800-90A)	Test runs at power-on before the integrity test

Algorithm or Test	Test Properties	Test Method	Test Type	Indicator	Details	Conditions
					Rev. 1 Section 11.3)	
KAS-FFC-SSC Sp800-56Ar3 (A5898)	ffdhe2048	KAT	CAST	Module becomes operational	Shared secret computation	Test runs at power-on before the integrity test
KAS-ECC-SSC Sp800-56Ar3 (A5868)	P-256	KAT	CAST	Module becomes operational	Shared secret computation	Test runs at power-on before the integrity test
KAS-ECC-SSC Sp800-56Ar3 (A5876)	P-256	KAT	CAST	Module becomes operational	Shared secret computation	Test runs at power-on before the integrity test
KAS-ECC-SSC Sp800-56Ar3 (A5877)	P-256	KAT	CAST	Module becomes operational	Shared secret computation	Test runs at power-on before the integrity test
KAS-ECC-SSC Sp800-56Ar3 (A5878)	P-256	KAT	CAST	Module becomes operational	Shared secret computation	Test runs at power-on before the integrity test
KAS-ECC-SSC Sp800-56Ar3 (A5879)	P-256	KAT	CAST	Module becomes operational	Shared secret computation	Test runs at power-on before the integrity test
KAS-ECC-SSC Sp800-56Ar3 (A5883)	P-256	KAT	CAST	Module becomes operational	Shared secret computation	Test runs at power-on before the integrity test
KAS-ECC-SSC Sp800-56Ar3 (A5889)	P-256	KAT	CAST	Module becomes operational	Shared secret computation	Test runs at power-on before the integrity test

© 2025 SUSE, LLC/atsec information security corporation.

This document can be reproduced and distributed only whole and intact, including this copyright notice.

Algorithm or Test	Test Properties	Test Method	Test Type	Indicator	Details	Conditions
Safe Primes Key Generation (A5898)	N/A	PCT	PCT	Key pair generation is successful	SP 800-56A Rev. 3 Section 5.6.2.1.4	Key pair generation
RSA KeyGen (FIPS186-5) (A5868)	PKCS#1 v1.5 with SHA-256	PCT	PCT	Key pair generation is successful	Signature generation and verification	Key pair generation
RSA KeyGen (FIPS186-5) (A5876)	PKCS#1 v1.5 with SHA-256	PCT	PCT	Key pair generation is successful	Signature generation and verification	Key pair generation
RSA KeyGen (FIPS186-5) (A5877)	PKCS#1 v1.5 with SHA-256	PCT	PCT	Key pair generation is successful	Signature generation and verification	Key pair generation
RSA KeyGen (FIPS186-5) (A5878)	PKCS#1 v1.5 with SHA-256	PCT	PCT	Key pair generation is successful	Signature generation and verification	Key pair generation
RSA KeyGen (FIPS186-5) (A5879)	PKCS#1 v1.5 with SHA-256	PCT	PCT	Key pair generation is successful	Signature generation and verification	Key pair generation
RSA KeyGen (FIPS186-5) (A5883)	PKCS#1 v1.5 with SHA-256	PCT	PCT	Key pair generation is successful	Signature generation and verification	Key pair generation
RSA KeyGen (FIPS186-5) (A5889)	PKCS#1 v1.5 with SHA-256	PCT	PCT	Key pair generation is successful	Signature generation and verification	Key pair generation
ECDSA KeyGen (FIPS186-5) (A5868)	SHA-256	PCT	PCT	Key pair generation is successful	Signature generation and verification	Key pair generation
ECDSA KeyGen (FIPS186-5) (A5876)	SHA-256	PCT	PCT	Key pair generation is successful	Signature generation and verification	Key pair generation

Algorithm or Test	Test Properties	Test Method	Test Type	Indicator	Details	Conditions
ECDSA KeyGen (FIPS186-5) (A5877)	SHA-256	PCT	PCT	Key pair generation is successful	Signature generation and verification	Key pair generation
ECDSA KeyGen (FIPS186-5) (A5878)	SHA-256	PCT	PCT	Key pair generation is successful	Signature generation and verification	Key pair generation
ECDSA KeyGen (FIPS186-5) (A5879)	SHA-256	PCT	PCT	Key pair generation is successful	Signature generation and verification	Key pair generation
ECDSA KeyGen (FIPS186-5) (A5883)	SHA-256	PCT	PCT	Key pair generation is successful	Signature generation and verification	Key pair generation
ECDSA KeyGen (FIPS186-5) (A5889)	SHA-256	PCT	PCT	Key pair generation is successful	Signature generation and verification	Key pair generation
KTS-IFC (A5868)	OAEP with 2048-bit key	KAT	CAST	Module becomes operational	Key encapsulation and un-encapsulation	Test runs at power-on before the integrity test
KTS-IFC (A5876)	OAEP with 2048-bit key	KAT	CAST	Module becomes operational	Key encapsulation and un-encapsulation	Test runs at power-on before the integrity test
KTS-IFC (A5877)	OAEP with 2048-bit key	KAT	CAST	Module becomes operational	Key encapsulation and un-encapsulation	Test runs at power-on before the integrity test
KTS-IFC (A5878)	OAEP with 2048-bit key	KAT	CAST	Module becomes operational	Key encapsulation and un-encapsulation	Test runs at power-on before the integrity test

Algorithm or Test	Test Properties	Test Method	Test Type	Indicator	Details	Conditions
KTS-IFC (A5879)	OAEP with 2048-bit key	KAT	CAST	Module becomes operational	Key encapsulation and un-encapsulation	Test runs at power-on before the integrity test
KTS-IFC (A5883)	OAEP with 2048-bit key	KAT	CAST	Module becomes operational	Key encapsulation and un-encapsulation	Test runs at power-on before the integrity test
KTS-IFC (A5889)	OAEP with 2048-bit key	KAT	CAST	Module becomes operational	Key encapsulation and un-encapsulation	Test runs at power-on before the integrity test

Table 23: Conditional Self-Tests

Data output through the data output interface is inhibited during the conditional self-tests. The module does not return control to the calling application until the tests are completed. If any of these tests fails, the module transitions to the error state (Section 10.4 Error States).

### 10.3 Periodic Self-Test Information

Algorithm or Test	Test Method	Test Type	Period	Periodic Method
HMAC-SHA2-256 (A5868)	Message authentication	SW/FW Integrity	On demand	Manually
HMAC-SHA2-256 (A5864)	Message authentication	SW/FW Integrity	On demand	Manually
HMAC-SHA2-256 (A5876)	Message authentication	SW/FW Integrity	On demand	Manually
HMAC-SHA2-256 (A5877)	Message authentication	SW/FW Integrity	On demand	Manually
HMAC-SHA2-256 (A5878)	Message authentication	SW/FW Integrity	On demand	Manually
HMAC-SHA2-256 (A5879)	Message authentication	SW/FW Integrity	On demand	Manually
HMAC-SHA2-256 (A5883)	Message authentication	SW/FW Integrity	On demand	Manually

© 2025 SUSE, LLC/atsec information security corporation.

This document can be reproduced and distributed only whole and intact, including this copyright notice.

<b>Algorithm or Test</b>	<b>Test Method</b>	<b>Test Type</b>	<b>Period</b>	<b>Periodic Method</b>
HMAC-SHA2-256 (A5889)	Message authentication	SW/FW Integrity	On demand	Manually

Table 24: Pre-Operational Periodic Information

<b>Algorithm or Test</b>	<b>Test Method</b>	<b>Test Type</b>	<b>Period</b>	<b>Periodic Method</b>
SHA-1 (A5868)	KAT	CAST	On Demand	Manually
SHA-1 (A5876)	KAT	CAST	On Demand	Manually
SHA-1 (A5877)	KAT	CAST	On Demand	Manually
SHA-1 (A5878)	KAT	CAST	On Demand	Manually
SHA-1 (A5879)	KAT	CAST	On Demand	Manually
SHA-1 (A5883)	KAT	CAST	On Demand	Manually
SHA-1 (A5889)	KAT	CAST	On Demand	Manually
SHA2-512 (A5868)	KAT	CAST	On Demand	Manually
SHA2-512 (A5876)	KAT	CAST	On Demand	Manually
SHA2-512 (A5877)	KAT	CAST	On Demand	Manually
SHA2-512 (A5878)	KAT	CAST	On Demand	Manually
SHA2-512 (A5879)	KAT	CAST	On Demand	Manually
SHA2-512 (A5883)	KAT	CAST	On Demand	Manually
SHA2-512 (A5889)	KAT	CAST	On Demand	Manually
HMAC-SHA2-256 (A5864)	KAT	CAST	On Demand	Manually

<b>Algorithm or Test</b>	<b>Test Method</b>	<b>Test Type</b>	<b>Period</b>	<b>Periodic Method</b>
HMAC-SHA2-256 (A5868)	KAT	CAST	On Demand	Manually
HMAC-SHA2-256 (A5876)	KAT	CAST	On Demand	Manually
HMAC-SHA2-256 (A5877)	KAT	CAST	On Demand	Manually
HMAC-SHA2-256 (A5878)	KAT	CAST	On Demand	Manually
HMAC-SHA2-256 (A5879)	KAT	CAST	On Demand	Manually
HMAC-SHA2-256 (A5883)	KAT	CAST	On Demand	Manually
HMAC-SHA2-256 (A5889)	KAT	CAST	On demand	Manually
SHA3-256 (A5869)	KAT	CAST	On Demand	Manually
SHA3-256 (A5885)	KAT	CAST	On Demand	Manually
AES-GCM (A5870)	KAT	CAST	On Demand	Manually
AES-GCM (A5871)	KAT	CAST	On Demand	Manually
AES-GCM (A5872)	KAT	CAST	On Demand	Manually
AES-GCM (A5873)	KAT	CAST	On Demand	Manually
AES-GCM (A5874)	KAT	CAST	On Demand	Manually
AES-GCM (A5875)	KAT	CAST	On Demand	Manually
AES-GCM (A5880)	KAT	CAST	On Demand	Manually

<b>Algorithm or Test</b>	<b>Test Method</b>	<b>Test Type</b>	<b>Period</b>	<b>Periodic Method</b>
AES-GCM (A5881)	KAT	CAST	On Demand	Manually
AES-GCM (A5882)	KAT	CAST	On Demand	Manually
AES-GCM (A5886)	KAT	CAST	On Demand	Manually
AES-GCM (A5887)	KAT	CAST	On Demand	Manually
AES-GCM (A5888)	KAT	CAST	On Demand	Manually
AES-GCM (A5903)	KAT	CAST	On Demand	Manually
AES-GCM (A5904)	KAT	CAST	On Demand	Manually
AES-GCM (A5905)	KAT	CAST	On Demand	Manually
AES-ECB (A5398)	KAT	CAST	On Demand	Manually
AES-ECB (A5399)	KAT	CAST	On Demand	Manually
AES-ECB (A5400)	KAT	CAST	On Demand	Manually
AES-ECB (A5401)	KAT	CAST	On Demand	Manually
AES-ECB (A5402)	KAT	CAST	On Demand	Manually
AES-ECB (A5403)	KAT	CAST	On Demand	Manually
AES-ECB (A5658)	KAT	CAST	On Demand	Manually
AES-ECB (A5884)	KAT	CAST	On Demand	Manually

<b>Algorithm or Test</b>	<b>Test Method</b>	<b>Test Type</b>	<b>Period</b>	<b>Periodic Method</b>
AES-ECB (A5893)	KAT	CAST	On Demand	Manually
AES-ECB (A5894)	KAT	CAST	On Demand	Manually
AES-ECB (A5895)	KAT	CAST	On Demand	Manually
AES-ECB (A5896)	KAT	CAST	On Demand	Manually
AES-ECB (A5900)	KAT	CAST	On Demand	Manually
RSA SigGen (FIPS186-5) (A5868)	KAT	CAST	On Demand	Manually
RSA SigGen (FIPS186-5) (A5869)	KAT	CAST	On Demand	Manually
RSA SigGen (FIPS186-5) (A5876)	KAT	CAST	On Demand	Manually
RSA SigGen (FIPS186-5) (A5877)	KAT	CAST	On Demand	Manually
RSA SigGen (FIPS186-5) (A5878)	KAT	CAST	On Demand	Manually
RSA SigGen (FIPS186-5) (A5879)	KAT	CAST	On Demand	Manually
RSA SigGen (FIPS186-5) (A5883)	KAT	CAST	On Demand	Manually
RSA SigGen (FIPS186-5) (A5885)	KAT	CAST	On Demand	Manually

<b>Algorithm or Test</b>	<b>Test Method</b>	<b>Test Type</b>	<b>Period</b>	<b>Periodic Method</b>
RSA SigGen (FIPS186-5) (A5889)	KAT	CAST	On Demand	Manually
RSA SigVer (FIPS186-5) (A5868)	KAT	CAST	On Demand	Manually
RSA SigVer (FIPS186-5) (A5869)	KAT	CAST	On Demand	Manually
RSA SigVer (FIPS186-5) (A5876)	KAT	CAST	On Demand	Manually
RSA SigVer (FIPS186-5) (A5877)	KAT	CAST	On Demand	Manually
RSA SigVer (FIPS186-5) (A5878)	KAT	CAST	On Demand	Manually
RSA SigVer (FIPS186-5) (A5879)	KAT	CAST	On Demand	Manually
RSA SigVer (FIPS186-5) (A5883)	KAT	CAST	On Demand	Manually
RSA SigVer (FIPS186-5) (A5885)	KAT	CAST	On Demand	Manually
RSA SigVer (FIPS186-5) (A5889)	KAT	CAST	On Demand	Manually
ECDSA SigGen (FIPS186-5) (A5868)	KAT	CAST	On Demand	Manually
ECDSA SigGen (FIPS186-5) (A5869)	KAT	CAST	On Demand	Manually

<b>Algorithm or Test</b>	<b>Test Method</b>	<b>Test Type</b>	<b>Period</b>	<b>Periodic Method</b>
ECDSA SigGen (FIPS186-5) (A5876)	KAT	CAST	On Demand	Manually
ECDSA SigGen (FIPS186-5) (A5877)	KAT	CAST	On Demand	Manually
ECDSA SigGen (FIPS186-5) (A5878)	KAT	CAST	On Demand	Manually
ECDSA SigGen (FIPS186-5) (A5879)	KAT	CAST	On Demand	Manually
ECDSA SigGen (FIPS186-5) (A5883)	KAT	CAST	On Demand	Manually
ECDSA SigGen (FIPS186-5) (A5885)	KAT	CAST	On Demand	Manually
ECDSA SigGen (FIPS186-5) (A5889)	KAT	CAST	On Demand	Manually
ECDSA SigVer (FIPS186-5) (A5868)	KAT	CAST	On Demand	Manually
ECDSA SigVer (FIPS186-5) (A5869)	KAT	CAST	On Demand	Manually
ECDSA SigVer (FIPS186-5) (A5876)	KAT	CAST	On Demand	Manually
ECDSA SigVer (FIPS186-5) (A5877)	KAT	CAST	On Demand	Manually
ECDSA SigVer (FIPS186-5) (A5878)	KAT	CAST	On Demand	Manually

<b>Algorithm or Test</b>	<b>Test Method</b>	<b>Test Type</b>	<b>Period</b>	<b>Periodic Method</b>
ECDSA SigVer (FIPS186-5) (A5879)	KAT	CAST	On Demand	Manually
ECDSA SigVer (FIPS186-5) (A5883)	KAT	CAST	On Demand	Manually
ECDSA SigVer (FIPS186-5) (A5885)	KAT	CAST	On Demand	Manually
ECDSA SigVer (FIPS186-5) (A5889)	KAT	CAST	On Demand	Manually
KDF SP800-108 (A5899)	KAT	CAST	On Demand	Manually
KDA OneStep SP800-56Cr2 (A5897)	KAT	CAST	On Demand	Manually
KDA TwoStep SP800-56Cr2 (A5897)	KAT	CAST	On Demand	Manually
KDA HKDF SP800-56Cr2 (A5863)	KAT	CAST	On Demand	Manually
KDF ANS 9.42 (A5868)	KAT	CAST	On Demand	Manually
KDF ANS 9.42 (A5869)	KAT	CAST	On Demand	Manually
KDF ANS 9.42 (A5876)	KAT	CAST	On Demand	Manually
KDF ANS 9.42 (A5877)	KAT	CAST	On Demand	Manually
KDF ANS 9.42 (A5878)	KAT	CAST	On Demand	Manually
KDF ANS 9.42 (A5879)	KAT	CAST	On Demand	Manually

<b>Algorithm or Test</b>	<b>Test Method</b>	<b>Test Type</b>	<b>Period</b>	<b>Periodic Method</b>
KDF ANS 9.42 (A5883)	KAT	CAST	On Demand	Manually
KDF ANS 9.42 (A5885)	KAT	CAST	On Demand	Manually
KDF ANS 9.42 (A5889)	KAT	CAST	On Demand	Manually
KDF ANS 9.63 (A5868)	KAT	CAST	On Demand	Manually
KDF ANS 9.63 (A5869)	KAT	CAST	On Demand	Manually
KDF ANS 9.63 (A5876)	KAT	CAST	On Demand	Manually
KDF ANS 9.63 (A5877)	KAT	CAST	On Demand	Manually
KDF ANS 9.63 (A5878)	KAT	CAST	On Demand	Manually
KDF ANS 9.63 (A5879)	KAT	CAST	On Demand	Manually
KDF ANS 9.63 (A5883)	KAT	CAST	On Demand	Manually
KDF ANS 9.63 (A5885)	KAT	CAST	On Demand	Manually
KDF ANS 9.63 (A5889)	KAT	CAST	On Demand	Manually
KDF SSH (A5884)	KAT	CAST	On Demand	Manually
KDF SSH (A5893)	KAT	CAST	On Demand	Manually
KDF SSH (A5894)	KAT	CAST	On Demand	Manually
KDF SSH (A5895)	KAT	CAST	On Demand	Manually

<b>Algorithm or Test</b>	<b>Test Method</b>	<b>Test Type</b>	<b>Period</b>	<b>Periodic Method</b>
KDF SSH (A5896)	KAT	CAST	On Demand	Manually
KDF SSH (A5900)	KAT	CAST	On Demand	Manually
TLS v1.2 KDF RFC7627 (A5868)	KAT	CAST	On Demand	Manually
TLS v1.2 KDF RFC7627 (A5876)	KAT	CAST	On Demand	Manually
TLS v1.2 KDF RFC7627 (A5877)	KAT	CAST	On Demand	Manually
TLS v1.2 KDF RFC7627 (A5878)	KAT	CAST	On Demand	Manually
TLS v1.2 KDF RFC7627 (A5879)	KAT	CAST	On Demand	Manually
TLS v1.2 KDF RFC7627 (A5883)	KAT	CAST	On Demand	Manually
TLS v1.2 KDF RFC7627 (A5889)	KAT	CAST	On Demand	Manually
TLS v1.3 KDF (A5863)	KAT	CAST	On Demand	Manually
PBKDF (A5868)	KAT	CAST	On Demand	Manually
PBKDF (A5869)	KAT	CAST	On Demand	Manually
PBKDF (A5876)	KAT	CAST	On Demand	Manually
PBKDF (A5877)	KAT	CAST	On Demand	Manually
PBKDF (A5878)	KAT	CAST	On Demand	Manually
PBKDF (A5879)	KAT	CAST	On Demand	Manually

<b>Algorithm or Test</b>	<b>Test Method</b>	<b>Test Type</b>	<b>Period</b>	<b>Periodic Method</b>
PBKDF (A5883)	KAT	CAST	On Demand	Manually
PBKDF (A5885)	KAT	CAST	On Demand	Manually
PBKDF (A5889)	KAT	CAST	On Demand	Manually
Counter DRBG (A5397)	KAT	CAST	On Demand	Manually
Hash DRBG (A5397)	KAT	CAST	On Demand	Manually
HMAC DRBG (A5397)	KAT	CAST	On Demand	Manually
KAS-FFC-SSC Sp800-56Ar3 (A5898)	KAT	CAST	On Demand	Manually
KAS-ECC-SSC Sp800-56Ar3 (A5868)	KAT	CAST	On Demand	Manually
KAS-ECC-SSC Sp800-56Ar3 (A5876)	KAT	CAST	On Demand	Manually
KAS-ECC-SSC Sp800-56Ar3 (A5877)	KAT	CAST	On Demand	Manually
KAS-ECC-SSC Sp800-56Ar3 (A5878)	KAT	CAST	On Demand	Manually
KAS-ECC-SSC Sp800-56Ar3 (A5879)	KAT	CAST	On Demand	Manually
KAS-ECC-SSC Sp800-56Ar3 (A5883)	KAT	CAST	On Demand	Manually
KAS-ECC-SSC Sp800-56Ar3 (A5889)	KAT	CAST	On Demand	Manually

<b>Algorithm or Test</b>	<b>Test Method</b>	<b>Test Type</b>	<b>Period</b>	<b>Periodic Method</b>
Safe Primes Key Generation (A5898)	PCT	PCT	On Demand	Manually
RSA KeyGen (FIPS186-5) (A5868)	PCT	PCT	On Demand	Manually
RSA KeyGen (FIPS186-5) (A5876)	PCT	PCT	On Demand	Manually
RSA KeyGen (FIPS186-5) (A5877)	PCT	PCT	On Demand	Manually
RSA KeyGen (FIPS186-5) (A5878)	PCT	PCT	On Demand	Manually
RSA KeyGen (FIPS186-5) (A5879)	PCT	PCT	On Demand	Manually
RSA KeyGen (FIPS186-5) (A5883)	PCT	PCT	On Demand	Manually
RSA KeyGen (FIPS186-5) (A5889)	PCT	PCT	On Demand	Manually
ECDSA KeyGen (FIPS186-5) (A5868)	PCT	PCT	On Demand	Manually
ECDSA KeyGen (FIPS186-5) (A5876)	PCT	PCT	On Demand	Manually
ECDSA KeyGen (FIPS186-5) (A5877)	PCT	PCT	On Demand	Manually
ECDSA KeyGen (FIPS186-5) (A5878)	PCT	PCT	On Demand	Manually

Algorithm or Test	Test Method	Test Type	Period	Periodic Method
ECDSA KeyGen (FIPS186-5) (A5879)	PCT	PCT	On Demand	Manually
ECDSA KeyGen (FIPS186-5) (A5883)	PCT	PCT	On Demand	Manually
ECDSA KeyGen (FIPS186-5) (A5889)	PCT	PCT	On Demand	Manually
KTS-IFC (A5868)	KAT	CAST	On demand	Manually
KTS-IFC (A5876)	KAT	CAST	On demand	Manually
KTS-IFC (A5877)	KAT	CAST	On demand	Manually
KTS-IFC (A5878)	KAT	CAST	On demand	Manually
KTS-IFC (A5879)	KAT	CAST	On demand	Manually
KTS-IFC (A5883)	KAT	CAST	On demand	Manually
KTS-IFC (A5889)	KAT	CAST	On demand	Manually

Table 25: Conditional Periodic Information

## 10.4 Error States

Name	Description	Conditions	Recovery Method	Indicator
Error	If the module fails any of the self-tests, the module enters the error state. In the error state, the module immediately stops functioning and ends the application process	Software integrity test failure CAST failure	Module reinitialization	OSSL_PROV_PARAM_STATUS is set to 0. Module will not load.
PCT Error	Pairwise consistency test failure	PCT failure	Module reinitialization	Module is aborted

Table 26: Error States

If the module fails any of the self-tests, the module enters the error state. In the error state, the module immediately stops functioning and ends the application process. Consequently, the data output interface is inhibited, and the module no longer accepts inputs or requests (as the module is no longer running).

## 10.5 Operator Initiation of Self-Tests

Both conditional and pre-operational self-tests can be executed on-demand by unloading and subsequently re-initializing the module, or by calling the `OSSL_PROVIDER_self_test` function. The pair-wise consistency tests can be invoked on demand by requesting the key pair generation service.

# 11 Life-Cycle Assurance

## 11.1 Installation, Initialization, and Startup Procedures

The module is distributed as a part of the SUSE Linux Enterprise 15 SP6 OpenSSL package in the form of the libopenssl-3-fips-provider-3.1.4-150600.5.15.1 RPM package.

Before the libopenssl-3-fips-provider-3.1.4-150600.5.15.1 RPM package is installed, the SUSE Linux Enterprise 15 SP6 system must operate in the FIPS validated configuration.

To do so the following steps shall be performed with the root privilege:

1. Install the needed crypto-policies scripts:

```
# zypper in crypto-policies-scripts
```

2. Set FIPS validated crypto-policies :

```
# update-crypto-policies --set FIPS
```

3. Append the following parameter in the /etc/default/grub configuration file in the GRUB\_CMDLINE\_LINUX\_DEFAULT line:

```
fips=1
```

4. After editing the configuration file, please run the following command to change the setting in the UEFI and BIOS boot loaders:

```
# grub2-mkconfig -o /boot/efi/EFI/sles/grub.cfg
```

```
# grub2-mkconfig -o /boot/grub2/grub.cfg
```

If /boot or /boot/efi resides on a separate partition, the kernel parameter boot=<partition of /boot or /boot/efi> must be supplied. The partition can be identified with the command "df /boot" or "df /boot/efi" respectively. For example:

```
# df /boot
```

Filesystem	1K-blocks	Used	Available	Use%	Mounted on
/dev/sda1	233191	30454	190296	14%	/boot

The partition of /boot is located on /dev/sda1 in this example. Therefore, the following string needs to be appended in the aforementioned grub file:

```
"boot=/dev/sda1"
```

5. Reboot to apply these settings.

Now, the operating environment is configured to support the approved mode of operation. The Crypto Officer should check the existence of the file /proc/sys/crypto/fips\_enabled, and verify it contains a numeric value "1". If the file does not exist or does not contain "1", the operating environment is not configured to support the approved mode of operation and the module will not operate as a FIPS validated module properly.

## 11.2 Administrator Guidance

After the libopenssl-3-fips-provider-3.1.4-150600.5.15.1 RPM package is installed, the Crypto Officer must execute the openssl list --providers command. This command should display the base/default and FIPS providers as follows:

```
Providers  
base
```

```
name: OpenSSL Base Provider
version: 3.1.4
status: active
default
name: OpenSSL Default Provider
version: 3.1.4
status: active
fips
name: SUSE Linux Enterprise - OpenSSL FIPS Provider
version: 3.1.4 SUSE release 150600.5.15.1
status: active
```

The cryptographic boundary consists only of the FIPS provider as listed. If any other OpenSSL or third-party provider is invoked, the user is not interacting with the module specified in this Security Policy.

### **11.3 Non-Administrator Guidance**

There is no Non-Administrator Guidance.

### **11.4 End of Life**

As the module does not persistently store SSPs, secure sanitization of the module consists of unloading the module. This will zeroize all SSPs in volatile memory. Then, if desired, the libopenssl-3-fips-provider-3.1.4-150600.5.15.1 RPM package can be uninstalled from the SUSE Linux Enterprise 15 SP6 system.

## 12 Mitigation of Other Attacks

### 12.1 Attack List

Certain cryptographic subroutines and algorithms are vulnerable to timing analysis. The module claims mitigation of timing-based side-channel attacks implementing two methods, Constant-time Implementations and Numeric Blinding:

- Constant-time Implementations protect cryptographic implementations in the module against timing cryptanalysis ensuring that the variations in execution time for different cryptographic algorithms cannot be traced back to the key, CSP or secret data.
- Numeric Blinding protects the RSA and ECDSA algorithms from timing attacks. These algorithms are vulnerable to such attacks since attackers can measure the time of signature operations or RSA decryption. To mitigate this, the module generates a random factor which is provided as an input to the decryption/signature operation which discarded once the operation results in an output. This makes it difficult for attackers to attempt timing attacks making impossible correlating execution time to the RSA/ECDSA key.

## Appendix A. Glossary and Abbreviations

AES	Advanced Encryption Standard
API	Application Programming Interface
CAST	Cryptographic Algorithm Self-Test
CAVP	Cryptographic Algorithm Validation Program
CBC	Cipher Block Chaining
CCM	Counter with Cipher Block Chaining-Message Authentication Code
CFB	Cipher Feedback
CKG	Cryptographic Key Generation
CMAC	Cipher-based Message Authentication Code
CMVP	Cryptographic Module Validation Program
CSP	Critical Security Parameter
CTR	Counter
DH	Diffie-Hellman
DRBG	Deterministic Random Bit Generator
ECB	Electronic Code Book
ECC	Elliptic Curve Cryptography
ECDH	Elliptic Curve Diffie-Hellman
ECDSA	Elliptic Curve Digital Signature Algorithm
EVP	Envelope
FFC	Finite Field Cryptography
FIPS	Federal Information Processing Standards
GCM	Galois Counter Mode
GMAC	Galois Counter Mode Message Authentication Code
HKDF	HMAC-based Key Derivation Function
HMAC	Keyed-Hash Message Authentication Code
IKE	Internet Key Exchange
KAS	Key Agreement Scheme
KAT	Known Answer Test
KBKDF	Key-based Key Derivation Function
KW	Key Wrap
KWP	Key Wrap with Padding
MAC	Message Authentication Code
NIST	National Institute of Science and Technology
OFB	Output Feedback
PAA	Processor Algorithm Acceleration
PCT	Pair-wise Consistency Test
PBKDF2	Password-based Key Derivation Function v2
PSS	Probabilistic Signature Scheme
RSA	Rivest, Shamir, Adleman

© 2025 SUSE, LLC/atsec information security corporation.

This document can be reproduced and distributed only whole and intact, including this copyright notice.

SHA	Secure Hash Algorithm
SSC	Shared Secret Computation
SSH	Secure Shell
SSP	Sensitive Security Parameter
TLS	Transport Layer Security
XOF	Extendable Output Function
XTS	XEX-based Tweaked-codebook mode with cipher text Stealing

## Appendix B. References

- ANS X9.42-2001**      **Public Key Cryptography for the Financial Services Industry: Agreement of Symmetric Keys Using Discrete Logarithm Cryptography**  
2001  
<https://webstore.ansi.org/standards/ascx9/ansix9422001>
- ANS X9.63-2001**      **Public Key Cryptography for the Financial Services Industry, Key Agreement and Key Transport Using Elliptic Curve Cryptography**  
2001  
<https://webstore.ansi.org/standards/ascx9/ansix9632001>
- FIPS 140-3**            **FIPS PUB 140-3 - Security Requirements for Cryptographic Modules**  
March 2019  
<https://nvlpubs.nist.gov/nistpubs/FIPS/NIST.FIPS.140-3.pdf>
- FIPS 140-3 IG**        **Implementation Guidance for FIPS PUB 140-3 and the Cryptographic Module Validation Program**  
23 October 2024  
<https://csrc.nist.gov/csrc/media/Projects/cryptographic-module-validation-program/documents/fips%20140-3/FIPS%20140-3%20IG.pdf>
- FIPS 180-4**            **Secure Hash Standard (SHS)**  
August 2015  
<https://nvlpubs.nist.gov/nistpubs/FIPS/NIST.FIPS.180-4.pdf>
- FIPS 186-2**            **Digital Signature Standard (DSS)**  
January 2000  
<https://nvlpubs.nist.gov/nistpubs/FIPS/NIST.FIPS.186-4.pdf>
- FIPS 186-4**            **Digital Signature Standard (DSS)**  
July 2013  
<https://nvlpubs.nist.gov/nistpubs/FIPS/NIST.FIPS.186-4.pdf>

<b>FIPS 186-5</b>	<b>Digital Signature Standard (DSS)</b> February 2023 <a href="https://nvlpubs.nist.gov/nistpubs/FIPS/NIST.FIPS.186-5.pdf">https://nvlpubs.nist.gov/nistpubs/FIPS/NIST.FIPS.186-5.pdf</a>
<b>FIPS 197</b>	<b>Advanced Encryption Standard</b> November 2001 <a href="https://csrc.nist.gov/publications/fips/fips197/fips-197.pdf">https://csrc.nist.gov/publications/fips/fips197/fips-197.pdf</a>
<b>FIPS 198-1</b>	<b>The Keyed Hash Message Authentication Code (HMAC)</b> July 2008 <a href="https://csrc.nist.gov/publications/fips/fips198-1/FIPS-198-1_final.pdf">https://csrc.nist.gov/publications/fips/fips198-1/FIPS-198-1_final.pdf</a>
<b>FIPS 202</b>	<b>SHA-3 Standard: Permutation-Based Hash and Extendable-Output Functions</b> August 2015 <a href="https://nvlpubs.nist.gov/nistpubs/FIPS/NIST.FIPS.202.pdf">https://nvlpubs.nist.gov/nistpubs/FIPS/NIST.FIPS.202.pdf</a>
<b>RFC 3526</b>	<b>More Modular Exponential (MODP) Diffie-Hellman groups for Internet Key Exchange (IKE)</b> May 2003 <a href="https://www.ietf.org/rfc/rfc3526.txt">https://www.ietf.org/rfc/rfc3526.txt</a>
<b>RFC 5288</b>	<b>AES Galois Counter Mode (GCM) Cipher Suites for TLS</b> August 2008 <a href="https://www.ietf.org/rfc/rfc5288.txt">https://www.ietf.org/rfc/rfc5288.txt</a>
<b>RFC 7919</b>	<b>Negotiated Finite Field Diffie-Hellman Ephemeral Parameters for Transport Layer Security (TLS)</b> August 2016 <a href="https://www.ietf.org/rfc/rfc7919.txt">https://www.ietf.org/rfc/rfc7919.txt</a>
<b>RFC 8446</b>	<b>The Transport Layer Security (TLS) Protocol Version 1.3</b> August 2018 <a href="https://www.ietf.org/rfc/rfc8446.txt">https://www.ietf.org/rfc/rfc8446.txt</a>
<b>SP 800-140B Rev. 1</b>	<b>NIST Special Publication 800-140B - CMVP Security Policy Requirements</b> October 2024 <a href="https://csrc.nist.gov/projects/cmvp/sp800-140b">https://csrc.nist.gov/projects/cmvp/sp800-140b</a>

- SP 800-38A**                    **Recommendation for Block Cipher Modes of Operation Methods and Techniques**  
December 2001  
<https://nvlpubs.nist.gov/nistpubs/Legacy/SP/nistspecialpublication800-38a.pdf>
- SP 800-38A Addendum**                    **Recommendation for Block Cipher Modes of Operation: Three Variants of Ciphertext Stealing for CBC Mode**  
October 2010  
<https://nvlpubs.nist.gov/nistpubs/Legacy/SP/nistspecialpublication800-38a-add.pdf>
- SP 800-38B**                    **Recommendation for Block Cipher Modes of Operation: The CMAC Mode for Authentication**  
May 2005  
<https://nvlpubs.nist.gov/nistpubs/SpecialPublications/NIST.SP.800-38b.pdf>
- SP 800-38C**                    **Recommendation for Block Cipher Modes of Operation: the CCM Mode for Authentication and Confidentiality**  
July 2007  
<https://nvlpubs.nist.gov/nistpubs/Legacy/SP/nistspecialpublication800-38c.pdf>
- SP 800-38D**                    **Recommendation for Block Cipher Modes of Operation: Galois/Counter Mode (GCM) and GMAC**  
November 2007  
<https://nvlpubs.nist.gov/nistpubs/Legacy/SP/nistspecialpublication800-38d.pdf>
- SP 800-38E**                    **Recommendation for Block Cipher Modes of Operation: The XTS AES Mode for Confidentiality on Storage Devices**  
January 2010  
<https://nvlpubs.nist.gov/nistpubs/Legacy/SP/nistspecialpublication800-38e.pdf>
- SP 800-38F**                    **Recommendation for Block Cipher Modes of Operation: Methods for Key Wrapping**  
December 2012  
<https://nvlpubs.nist.gov/nistpubs/SpecialPublications/NIST.SP.800-38F.pdf>

- SP 800-52 Rev. 2**      **Guidelines for the Selection, Configuration, and Use of Transport Layer Security (TLS) Implementations**  
August 2019  
<https://nvlpubs.nist.gov/nistpubs/SpecialPublications/NIST.SP.800-52r2.pdf>
- SP 800-56A Rev. 3**      **Recommendation for Pair-Wise Key Establishment Schemes Using Discrete Logarithm Cryptography**  
April 2018  
<https://nvlpubs.nist.gov/nistpubs/SpecialPublications/NIST.SP.800-56Ar3.pdf>
- SP 800-56C Rev. 2**      **Recommendation for Key-Derivation Methods in Key-Establishment Schemes**  
August 2020  
<https://nvlpubs.nist.gov/nistpubs/SpecialPublications/NIST.SP.800-56Cr2.pdf>
- SP 800-90A Rev. 1**      **Recommendation for Random Number Generation Using Deterministic Random Bit Generators**  
June 2015  
<https://nvlpubs.nist.gov/nistpubs/SpecialPublications/NIST.SP.800-90Ar1.pdf>
- SP 800-90B**              **Recommendation for the Entropy Sources Used for Random Bit Generation**  
January 2018  
<https://nvlpubs.nist.gov/nistpubs/SpecialPublications/NIST.SP.800-90B.pdf>
- SP 800-108 Rev. 1**      **NIST Special Publication 800-108r1 - Recommendation for Key Derivation Using Pseudorandom Functions**  
August 2022  
<https://nvlpubs.nist.gov/nistpubs/SpecialPublications/NIST.SP.800-108r1-upd1.pdf>
- SP 800-132**              **Recommendation for Password-Based Key Derivation - Part 1: Storage Applications**  
December 2010  
<https://nvlpubs.nist.gov/nistpubs/Legacy/SP/nistspecialpublication800-132.pdf>

**SP 800-133 Rev. 2 Recommendation for Cryptographic Key Generation**

June 2020

<https://nvlpubs.nist.gov/nistpubs/SpecialPublications/NIST.SP.800-133r2.pdf>**SP 800-135 Rev. 1 Recommendation for Existing Application-Specific Key Derivation Functions**

December 2011

<https://nvlpubs.nist.gov/nistpubs/Legacy/SP/nistspecialpublication800-135r1.pdf>