



## Pulse Secure Cryptographic Module

---

### FIPS 140-2 Level 1 Security Policy

Version: 1.1

Last Updated: December 16, 2015

Pulse Secure, LLC  
2700 Zanker Road, Suite 200  
San Jose, CA 95134  
<http://www.pulsesecure.net>

© 2015 by Pulse Secure, LLC. All rights reserved. This document may be freely reproduced and distributed whole and intact including this Copyright Notice.

## Revision History

Authors	Date	Version	Comment
Pulse Secure, LLC	2015-12-16	1.1	Deprecation of X9.31 RNG and Dual EC DRBG
Pulse Secure, LLC	2014-12-16	1.1	Changes for rebranding

## Table of Contents

Revision History .....	2
1 Introduction.....	4
2 Tested Configurations.....	5
3 Ports and Interfaces.....	5
4 Modes of Operation and Cryptographic Functionality .....	6
4.1 Critical Security Parameters and Public Keys.....	9
5 Roles, Authentication and Services .....	11
6 Self-test .....	12
7 Operational Environment.....	14
8 Mitigation of other attacks .....	14

# 1 Introduction

This document comprises the non-proprietary FIPS 140-2 Security Policy for the Pulse Secure Cryptographic Module, hereafter referred to as the Module.

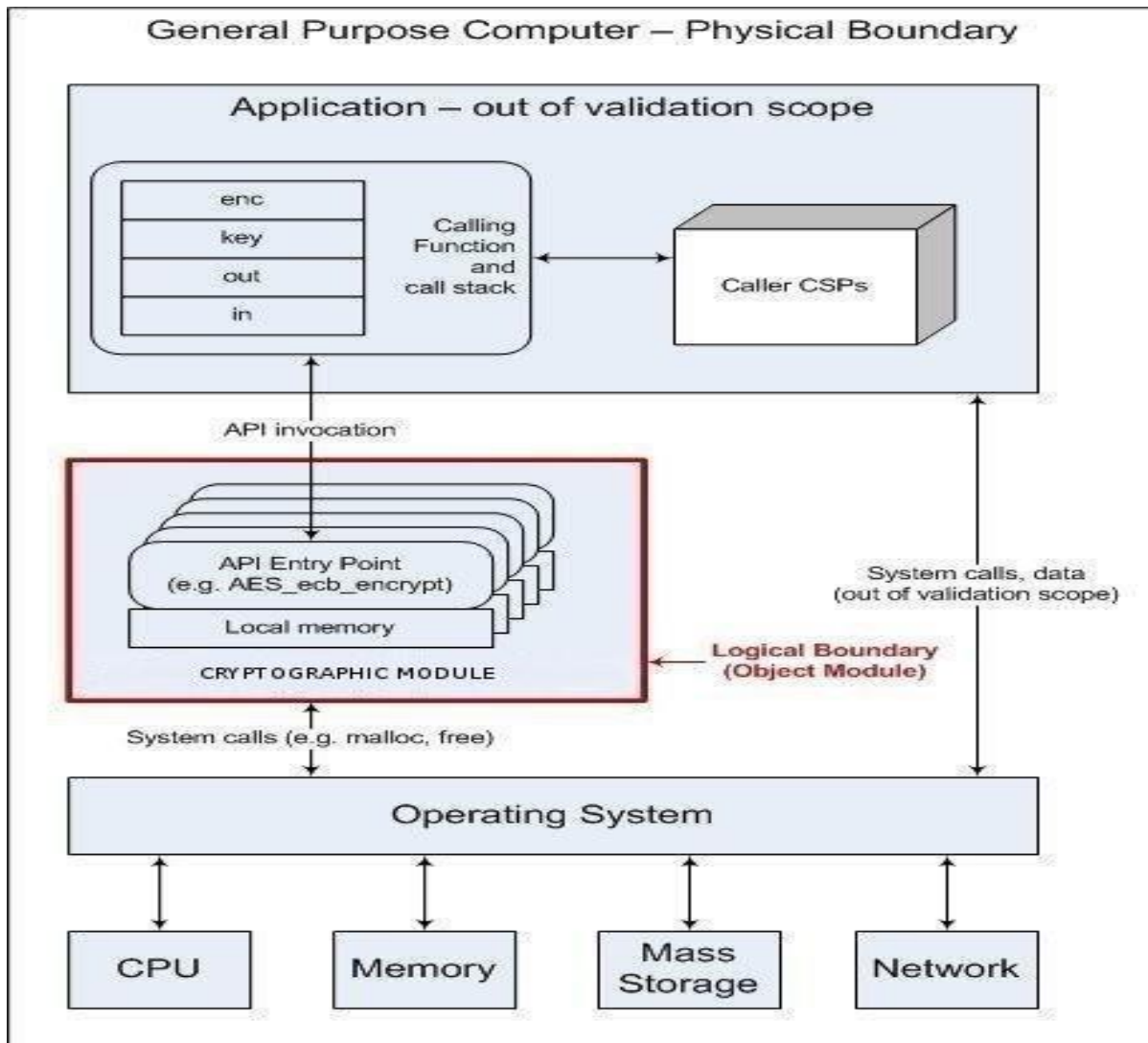

Block Diagram

The Module is a software library providing a C-language application program interface (API) for use by other processes that require cryptographic functionality. The Module is classified by FIPS 140-2 as a software module, multi-chip standalone module embodiment. The physical cryptographic boundary is the general purpose computer on which the module is installed. The logical cryptographic boundary of the Module is the fipsanister object module, a single object

module file named *fipscanister.o*. The Module performs no communications other than with the calling application (the process that invokes the Module services).

The FIPS 140-2 security levels for the Module are as follows:

Security Requirement	Security Level
Cryptographic Module Specification	1
Cryptographic Module Ports and Interfaces	1
Roles, Services, and Authentication	2
Finite State Model	1
Physical Security	NA
Operational Environment	1
Cryptographic Key Management	1
EMI/EMC	1
Self-Tests	1
Design Assurance	1
Mitigation of Other Attacks	NA

*Table 1 – Security Level of Security Requirements*

The Module's software version for this validation is 1.1.

## 2 Tested Configurations

	Operational Environment	Processor	Optimizations (Target)	Hardware Device
1	IVE OS 1.1 32-bit	Intel Pentium E2160 (x86)	None	Juniper MAG4610
2	IVE OS 1.1 32-bit on VMware ESX	Intel Xeon CPU E5530 (x86)	None	HP ProLiant BL2x220c G6 Blade Server
3	IVE OS 1.1 32-bit on VMware ESXi	Intel Xeon CPU X5670 (x86)	AES-NI	IBM HS22 Blade Server
4	Microsoft Windows 7 32-bit	Intel Celeron (x86)	None	Dell Poweredge 860
5	Microsoft Windows 7 32-bit	Intel Core i5-2430M (x86)	AES-NI	Acer Aspire
6	Microsoft Windows 7 64-bit	Intel Pentium 4 (x86)	None	Dell Poweredge 850
7	Microsoft Windows 7 64-bit	Intel Core i5-2430M (x86)	AES-NI	Acer Aspire
8	OS X 10.8 64-bit	Intel Core i7-3615QM (x86)	AES-NI	Macbook Pro
9	IVE OS 1.1 32-bit on VMware ESXi	Intel Xeon CPU X5670 (x86)	None	IBM HS22 Blade Server

10	OS X 10.8 64-bit	Intel Core i7-3615QM (x86)	None	Macbook Pro
----	------------------	----------------------------	------	-------------

Table 2 - Supported Platforms

### 3 Ports and Interfaces

The physical ports of the Module are the same as the computer system on which it is executing. The logical interface is a C-language application program interface (API).

Logical interface type	Description
Control input	API entry point and corresponding stack parameters
Data input	API entry point data input stack parameters
Status output	API entry point return values and status stack parameters
Data output	API entry point data output stack parameters

Table 3 - Logical interfaces

As a software module, control of the physical ports is outside module scope. However, when the module is performing self-tests, or is in an error state, all output on the logical data output interface is inhibited. The module is single-threaded and in error scenarios returns only an error value (no data output is returned).

### 4 Modes of Operation and Cryptographic Functionality

The Module supports only a FIPS 140-2 Approved mode. Tables 4a and 4b list the Approved and Non-approved but Allowed algorithms, respectively.

Function	Algorithm	Options	Cert #
Random Number Generation; Symmetric key generation	[SP 800-90] DRBG <sup>1</sup> Prediction resistance supported for all variations	Hash DRBG HMAC DRBG, no reseed CTR DRBG (AES), no derivation function	157, 383
Encryption, Decryption and CMAC	[SP 800-67]	3-Key TDES ECB, TCBC, TCFB, TOFB; CMAC generate and verify	1223, 1545
	[FIPS 197] AES	128/ 192/256 ECB, CBC, OFB, CFB 1, CFB 8, CFB 128, CTR, XTS; CCM; GCM; CMAC generate and verify	1884, 2553
	[SP 800-38B] CMAC		
	[SP 800-38C] CCM [SP 800-38D] GCM [SP 800-38E] XTS		

<sup>1</sup> For all DRBGs the "supported security strengths" is just the highest supported security strength per [SP800-90] and [SP800-57]

Pulse Secure Cryptographic Module Security Policy

Message Digests	[FIPS 180-3]	SHA-1, SHA-2 (224, 256, 384, 512)	1655, 2153
Keyed Hash	[FIPS 198] HMAC	SHA-1, SHA-2 (224, 256, 384, 512)	1126, 1573
Digital Signature and Asymmetric Key Generation	[FIPS 186-2] RSA	SigVer9.31, SigVerPKCS1.5, SigVerPSS (1024/1536/2048/3072/4096 with all SHA sizes) GenKey9.31, SigGen9.31, SigGenPKCS1.5, SigGenPSS (2048/3072/4096 with all SHA-2 sizes)	960, 1306
	[FIPS 186-2] DSA	PQG Ver, Sig Ver (1024 with SHA-1 only)	589, 780
	[FIPS 186-3] DSA	PQG Ver, Sig Ver (1024/2048/3072 with all SHA sizes) PQG Gen, Key Pair Gen, Sig Gen (2048/3072 with all SHA-2 sizes)	589, 780
	[FIPS 186-2] ECDSA	PKG: CURVES( P-224 P-384 P-521 K-233 K-283 K-409 K-571 B-233 B-283 B-409 B-571 ) PKV: CURVES( P-192 P-224 P-256 P-384 P-521 K-163 K-233 K-283 K-409 K-571 B-163 B-233 B-283 B-409 B-571 )	270, 438
	[FIPS 186-3] ECDSA	PKG: CURVES( P-224 P-256 P-384 P-521 K-224 K-256 K-384 K-521 B-224 B-256 B-384 B-521 ExtraRandomBits TestingCandidates ) PKV: CURVES( ALL-P ALL-K ALL-B ) SigGen: CURVES( P-224: (SHA-224, 256, 384, 512) P-256: (SHA-224, 256, 384, 512) P-384: (SHA-224, 256, 384, 512) P-521: (SHA-224, 256, 384, 512) K-233: (SHA-224, 256, 384, 512) K-283: (SHA-224, 256, 384, 512) K-409: (SHA-224, 256, 384, 512) K-571: (SHA-224, 256, 384, 512) B-233: (SHA-224, 256, 384, 512) B-283: (SHA-224, 256, 384, 512) B-409: (SHA-224, 256, 384, 512) B-571: (SHA-224, 256, 384, 512) ) SigVer: CURVES( P-192: (SHA-1, 224, 256, 384, 512) P-224: (SHA-1, 224, 256, 384, 512) P-256: (SHA-1, 224, 256, 384, 512) P-384: (SHA-1, 224, 256, 384, 512) P-521: (SHA-1, 224, 256, 384, 512) K-163: (SHA-1, 224, 256, 384, 512) K-233: (SHA-1, 224, 256, 384, 512) K-283: (SHA-1, 224, 256, 384, 512) K-409: (SHA-1, 224, 256, 384, 512) K-571: (SHA-1, 224, 256, 384, 512) B-163: (SHA-1, 224, 256, 384, 512) B-233: (SHA-1, 224, 256, 384, 512) B-283: (SHA-1, 224, 256, 384, 512) B-409: (SHA-1, 224, 256, 384, 512) B-571: (SHA-1, 224, 256, 384, 512) )	270, 438
ECC CDH (CVL)	[SP 800-56A] (§5.7.1.2)	All NIST defined B, K and P curves	12, 91

Table 4a – FIPS Approved Cryptographic Functions

The Module supports only NIST defined curves for use with ECDSA and ECC CDH. Refer to the transition tables available at the CMVP Web site (<http://csrc.nist.gov/groups/STM/cmvp/>)

Category	Algorithm	Description
Key Agreement	EC DH	Non-compliant (untested) DH scheme using elliptic curve, supporting all NIST defined B, K and P curves. Key agreement is a service provided for calling process use, but is not used to establish keys into the Module.
Key Encryption, Decryption	RSA	The RSA algorithm may be used by the calling application for encryption or decryption of keys. No claim is made for SP 800-56B compliance, and no CSPs are established into or exported out of the module using these services.

Table 4b – Non-FIPS Approved But Allowed Cryptographic Functions

The Module implements the following services which are Non-Approved per the SP 800-131A transition:

Function	Algorithm	Options	Cert #
Random Number Generation; Symmetric key generation	[ANSI X9.31] RNG	AES 128/192/256	985, 1212
Random Number Generation; Symmetric key generation	[SP 80090] DRBG	Dual EC DRBG (note the Dual EC DRBG algorithm shall not be used in the FIPS Approved mode of operation)	157, 383
Digital Signature and Asymmetric Key Generation	[FIPS 186-2] RSA	GenKey9.31, SigGen9.31, SigGenPKCS1.5, SigGenPSS (1024/1536 with all SHA sizes, 2048/3072/4096 with SHA-1)	960, 1306
	[FIPS 186-2] DSA	PQG Gen, Key Pair Gen, Sig Gen (1024 with all SHA sizes, 2048/3072 with SHA-1)	589, 780
	[FIPS 186-3] DSA	PQG Gen, Key Pair Gen, Sig Gen (1024 with all SHA sizes, 2048/3072 with SHA-1)	589, 780
	[FIPS 186-2] ECDSA	PKG: CURVES( P-192 K-163 B-163 ) SIG(gen): CURVES( P-192 P-224 P-256 P-384 P-521 K-163 K-233 K-283 K-409 K-571 B-163 B-233 B-283 B-409 B-571 )	270, 438
	[FIPS 186-4] ECDSA	PKG: CURVES( P-192 K-163 B-163 ) SigGen: CURVES( P-192: (SHA-1, 224, 256, 384, 512) P-224:(SHA-1) P-256:(SHA-1) P-384:(SHA-1) P-521:(SHA-1) K-163: (SHA-1, 224, 256, 384, 512) K-233:(SHA-1) K-283:(SHA-1) K-409:(SHA-1) K-571:(SHA-1) B-163: (SHA-1, 224, 256, 384, 512) B-233:(SHA-1) B-283:(SHA-1) B-409:(SHA-1) B-571:(SHA-1) )	270,4 38
ECC CDH (CVL)	[SP 800-56A] (§5.7.1.2)	All NIST Recommended B, K and P curves sizes 163 and 192	12, 91

Table 4c – FIPS Non-Approved Cryptographic Functions

X9.31 RNG is NonApproved effective December 31, 2015, per the CMVP Notice "X9.31 RNG transition, December 31, 2015". These Non\_Approved algorithms shall not be used when operating in the FIPS Approved mode of operation.



The Module supports only a FIPS 140-2 Approved mode. The Module requires an initialization sequence (see IG 9.5): the calling application invokes `FIPS_mode_set()`<sup>2</sup>, which returns a “1” for success and “0” for failure. If `FIPS_mode_set()` fails then all cryptographic services fail from then on. The application can test to see if FIPS mode has been successfully performed.

The Module is a cryptographic engine library, which can be used only in conjunction with additional software. Aside from the use of the NIST defined elliptic curves as trusted third party domain parameters, all other FIPS 186-3 assurances are outside the scope of the Module, and are the responsibility of the calling process.

#### 4.1 Critical Security Parameters and Public Keys

All CSPs used by the Module are described in this section. All access to these CSPs by Module services are described in Section 4. The CSP names are generic, corresponding to API parameter data structures.

CSP Name	Description
RSA SGK	RSA (1024 to 16384 bits) signature generation key
RSA KDK	RSA (1024 to 16384 bits) key decryption (private key transport) key
DSA SGK	[FIPS 186-3] DSA (1024/2048/3072) signature generation key or [FIPS 186-2] DSA (1024) signature generation key
ECDSA SGK	ECDSA (All NIST defined B, K, and P curves) signature generation key
EC DH Private	EC DH (All NIST defined B, K, and P curves) private key agreement key.
AES EDK	AES (128/192/256) encrypt / decrypt key
AES CMAC	AES (128/192/256) CMAC generate / verify key
AES XTS	AES (256/512) XTS cipher key
TDES EDK	TDES (3-Key) encrypt / decrypt key
TDES CMAC	TDES (3-Key) CMAC generate / verify key
HMAC Key	Keyed hash key (160/224/256/384/512)
Hash_DRBG CSPs	V (440/888 bits) and C (440/888 bits), entropy input (length dependent on security strength)
HMAC_DRBG CSPs	V (160/224/256/384/512 bits) and Key (160/224/256/384/512 bits), entropy input (length dependent on security strength)
CTR_DRBG CSPs	V (128 bits) and Key (AES 128/192/256), entropy input (length dependent on security strength)
CO-AD-Digest	Pre-calculated HMAC-SHA-1 <sup>3</sup> digest used for Crypto Officer role authentication
User-AD-Digest	Pre-calculated HMAC-SHA-1 digest used for User role authentication

Table 4.1a – Critical Security Parameters

Authentication data is loaded into the module during the module build process, performed by an authorized operator (Crypto Officer), and otherwise cannot be accessed.

The module does not output intermediate key generation values. The module generates cryptographic keys whose strengths are modified by available entropy.

<sup>2</sup> The function call in the Module is `FIPS_module_mode_set()` which is typically used by an application via the `FIPS_mode_set()`

<sup>3</sup> For HMAC-SHA-1 the required key size must be at least 112 bits

CSP Name	Description
RSA SVK	RSA (1024 to 16384 bits) signature verification public key
RSA KEK	RSA (1024 to 16384 bits) key encryption (public key transport) key
DSA SVK	[FIPS 186-3] DSA (1024/2048/3072) signature verification key or [FIPS 186-2] DSA (1024) signature verification key
ECDSA SVK	ECDSA (All NIST defined B, K and P curves) signature verification key
EC DH Public	EC DH (All NIST defined B, K and P curves) public key agreement key.

Table 4.1b – Public Keys

**For all CSPs and Public Keys:**

**Storage:** RAM, associated to entities by memory location. The Module stores RNG and DRBG state values for the lifetime of the RNG or DRBG instance. The module uses CSPs passed in by the calling application on the stack. The Module does not store any CSP persistently (beyond the lifetime of an API call), with the exception of RNG and DRBG state values used for the Modules' default key generation service.

**Generation:** The Module implements SP 800-90 compliant DRBG services for creation of symmetric keys, and for generation of DSA, elliptic curve, and RSA keys as shown in Table 4a. The calling application is responsible for storage of generated keys returned by the module.

**Entry:** All CSPs enter the Module's logical boundary in plaintext as API parameters, associated by memory location. However, none cross the physical boundary.

**Output:** The Module does not output CSPs, other than as explicit results of key generation services. However, none cross the physical boundary.

**Destruction:** Zeroization of sensitive data is performed automatically by API function calls for temporarily stored CSPs. In addition, the module provides functions to explicitly destroy CSPs related to random number generation services. The calling application is responsible for parameters passed in and out of the module.

Private and secret keys as well as seeds and entropy input are provided to the Module by the calling application, and are destroyed when released by the appropriate API function calls. Keys residing in internally allocated data structures (during the lifetime of an API call) can only be accessed using the Module defined API. The operating system protects memory and process space from unauthorized access. Only the calling application that creates or imports keys can use or export such keys. All API functions are executed by the invoking calling application in a non-overlapping sequence such that no two API functions will execute concurrently. An authorized application as user (Crypto-Officer and User) has access to all key data generated during the operation of the Module.

In the event Module power is lost and restored the calling application must ensure that any AES-GCM keys used for encryption or decryption are re-distributed.

Module users (the calling applications) shall use entropy sources that meet the security strength required for the random number generation mechanism as shown in [SP 800-90] Table 2 (Hash\_DRBG, HMAC\_DRBG), Table 3

(CTR\_DRBG). This entropy is supplied by means of callback functions. Those functions must return an error if the minimum entropy strength cannot be met.

## 5 Roles, Authentication and Services

The Module implements the required User and Crypto Officer roles and requires authentication for those roles. Only one role may be active at a time and the Module does not allow concurrent operators. The User or Crypto Officer role is assumed by passing the appropriate password to the `FIPS_module_mode_set()` function. The password values may be specified at build time and must have a minimum length of 16 characters. Any attempt to authenticate with an invalid password will result in an immediate and permanent failure condition rendering the Module unable to enter the FIPS mode of operation, even with subsequent use of a correct password.

Authentication data is loaded into the Module during the Module build process, performed by the Crypto Officer, and otherwise cannot be accessed.

Since minimum password length is 16 characters, the probability of a random successful authentication attempt in one try is a maximum of  $1/256^{16}$ , or less than  $1/10^{38}$ . The Module permanently disables further authentication attempts after a single failure, so this probability is independent of time.

Both roles have access to all of the services provided by the Module.

- User Role (User): Loading the Module and calling any of the API functions.
- Crypto Officer Role (CO): Installation of the Module on the host computer system and calling of any API functions.

All services implemented by the Module are listed below, along with a description of service CSP access.

Service	Role	Description
Initialize	User, CO	Module initialization, inclusive of all Table 9 tests ( <code>FIPS_module_mode_set</code> ). Does not access CSPs.
Self-test	User, CO	Perform all Table 9 tests ( <code>FIPS_selftest</code> ). Does not access CSPs.
Show status	User, CO	Functions that provide module status information: <ul style="list-style-type: none"> <li>• Version (as unsigned long or const char *)</li> <li>• FIPS Mode (Boolean)</li> </ul> Does not access CSPs.
Zeroize	User, CO	Functions that destroy CSPs: <ul style="list-style-type: none"> <li>• <code>fips_rand_prng_reset</code>: destroys RNG CSPs.</li> <li>• <code>fips_drbg_uninstantiate</code>: for a given DRBG context, overwrites DRBG CSPs (Hash_DRBG CSPs, HMAC_DRBG CSPs, CTR_DRBG CSPs)</li> </ul> All other services automatically overwrite CSPs stored in allocated memory. Stack cleanup is the responsibility of the calling application.

Service	Role	Description
Random number generation	User, CO	Used for random number and symmetric key generation. <ul style="list-style-type: none"> <li>Seed or reseed an RNG or DRBG instance</li> <li>Determine security strength of an RNG or DRBG instance</li> <li>Obtain random data</li> </ul> Uses and updates RNG CSPs, Hash_DRBG CSPs, HMAC_DRBG CSPs, CTR_DRBG CSPs.
Asymmetric key generation	User, CO	Used to generate DSA, ECDSA and RSA keys: RSA SGK, RSA SVK; DSA SGK, DSA SVK; ECDSA SGK, ECDSA SVK There is one supported entropy strength for each mechanism and algorithm type, the maximum specified in SP800-90
Symmetric encrypt/decrypt	User, CO	Used to encrypt or decrypt data. Executes using AES EDK, TDES EDK (passed in by the calling process).
Symmetric digest	User, CO	Used to generate or verify data integrity with CMAC. Executes using AES CMAC, TDES, CMAC (passed in by the calling process).
Message digest	User, CO	Used to generate a SHA-1 or SHA-2 message digest. Does not access CSPs.
Keyed Hash	User, CO	Used to generate or verify data integrity with HMAC. Executes using HMAC Key (passed in by the calling process).
Key transport <sup>4</sup>	User, CO	Used to encrypt or decrypt a key value on behalf of the calling process (does not establish keys into the module). Executes using RSA KDK, RSA KEK (passed in by the calling process).
Key agreement	User, CO	Used to perform key agreement primitives on behalf of the calling process (does not establish keys into the module). Executes using EC DH Private, EC DH Public (passed in by the calling process).
Digital signature	User, CO	Used to generate or verify RSA, DSA or ECDSA digital signatures. Executes using RSA SGK, RSA SVK; DSA SGK, DSA SVK; ECDSA SGK, ECDSA SVK (passed in by the calling process).
Utility	User, CO	Miscellaneous helper functions. Does not access CSPs.

Table 5 - Services and CSP Access

## 6 Self-test

The Module performs the self-tests listed below on invocation of Initialize or Self-test.

Algorithm	Type	Test Attributes
Software integrity	KAT	HMAC-SHA1
HMAC	KAT	One KAT per SHA1, SHA224, SHA256, SHA384 and SHA512 Per IG 9.3, this testing covers SHA POST requirements.
AES	KAT	Separate encrypt and decrypt, ECB mode, 128 bit key length

<sup>4</sup> "Key transport" can refer to a) moving keys in and out of the module or b) the use of keys by an external application. The latter definition is the one that applies to this Module.

Algorithm	Type	Test Attributes
AES CCM	KAT	Separate encrypt and decrypt, 192 key length
AES GCM	KAT	Separate encrypt and decrypt, 256 key length
XTS-AES	KAT	128, 256 bit key sizes to support either the 256-bit key size (for XTS-AES-128) or the 512-bit key size (for XTS-AES-256)
AES CMAC	KAT	Sign and verify CBC mode, 128, 192, 256 key lengths
TDES	KAT	Separate encrypt and decrypt, ECB mode, 3-Key
TDES CMAC	KAT	CMAC generate and verify, CBC mode, 3-Key
RSA	KAT	Sign and verify using 2048 bit key, SHA-256, PKCS#1
DSA	PCT	Sign and verify using 2048 bit key, SHA-384
DRBG	KAT	CTR_DRBG: AES, 256 bit with and without derivation function HASH_DRBG: SHA256 HMAC_DRBG: SHA256
ECDSA	PCT	Keygen, sign, verify using P-224, K-233 and SHA512. The K-233 self-test is not performed for operational environments that support prime curve only (see Table 2).
ECC CDH	KAT	Shared secret calculation per SP 800-56A §5.7.1.2, IG 9.6

Table 6a - Power On Self Tests (KAT = Known answer test; PCT = Pairwise consistency test)

The `FIPS_mode_set()`<sup>5</sup> function performs all power-up self-tests listed above with no operator intervention required, returning a “1” if all power-up self-tests succeed, and a “0” otherwise. If any component of the power-up self-test fails an internal flag is set to prevent subsequent invocation of any cryptographic function calls. The module will only enter the FIPS Approved mode if the module is reloaded and the call to `FIPS_mode_set()`<sup>5</sup> succeeds.

The power-up self-tests may also be performed on-demand by calling `FIPS_selftest()`, which returns a “1” for success and “0” for failure. Interpretation of this return code is the responsibility of the calling application.

The Module also implements the following conditional tests:

Algorithm	Test
DRBG	Tested as required by [SP800-90] Section 11
DRBG	FIPS 140-2 continuous test for stuck fault
DRBG	KAT for Dual_EC_DRBG
DSA	Pairwise consistency test on each generation of a key pair
ECDSA	Pairwise consistency test on each generation of a key pair
RSA	Pairwise consistency test on each generation of a key pair

<sup>5</sup> `FIPS_mode_set()` calls Module function `FIPS_module_mode_set()`

Algorithm	Test
ANSI X9.31 RNG	Continuous test for stuck fault
ANSI X9.31 RNG	KAT for 128, 192, 256 bit AES keys

*Table 6b - Conditional Tests*

In the event of a DRBG self-test failure the calling application must uninstantiate and re-instantiate the DRBG per the requirements of [SP 800-90]; this is not something the Module can do itself.

Pairwise consistency tests are performed for both possible modes of use, e.g. Sign/Verify and Encrypt/Decrypt.

## 7 Operational Environment

The tested operating systems segregate user processes into separate process spaces. Each process space is logically separated from all other processes by the operating system software and hardware. The Module functions entirely within the process space of the calling application, and implicitly satisfies the FIPS 140-2 requirement for a single user mode of operation.

## 8 Mitigation of other attacks

The module is not designed to mitigate against attacks which are outside of the scope of FIPS 140-2.