



Summit Linux FIPS Core Crypto Module

Software Version 7.1

Hardware Version ATSAMA5D31, ATSAMA5D36

FIPS 140-2 Non-Proprietary Security Policy

Document Version 1.2

Last update: 2024-04-15

Prepared by:

atsec information security corporation

4516 Seton Center Pkwy, Suite 250

Austin, TX 78759

www.atsec.com

Table of Contents

1	Introduction	5
1.1	Purpose of the Security Policy	5
1.2	Target Audience.....	5
1.3	How this Security Policy was Prepared	5
2	Cryptographic Module Specification.....	6
2.1	Module Overview	6
2.2	FIPS 140-2 Validation Scope.....	6
2.3	Definition of the Cryptographic Module and its Cryptographic Boundaries	6
2.4	Tested Operational Environments	9
2.5	Modes of Operation.....	10
3	Module Ports and Interfaces	11
4	Roles, Services and Authentication	12
4.1	Roles	12
4.2	Services.....	12
4.2.1	Services in the FIPS-Approved Mode of Operation	12
4.2.2	Services in the Non-FIPS-Approved Mode of Operation	14
4.3	Algorithms	18
4.3.1	Approved Algorithms	18
4.3.2	Non-Approved-but-Allowed Algorithms	24
4.3.3	Non-Approved Algorithms	24
4.4	Operator Authentication	26
5	Physical Security	27
6	Operational Environment.....	28
6.1	Applicability	28
6.2	Policy.....	28
7	Cryptographic Key Management	29
7.1	Random Number Generation.....	32
7.2	Key Generation	32
7.3	Key Entry/Output.....	32
7.4	Key/CSP Storage	33
7.5	Key/CSP Zeroization.....	33
7.6	Key Establishment	33
8	Electromagnetic Interference/Electromagnetic Compatibility (EMI/EMC).....	34
9	Self-Tests.....	35
9.1	Power-Up Self-Tests.....	35

9.2	Conditional Self-Tests	36
9.3	On-Demand Self-tests	36
10	Guidance.....	37
10.1	Crypto-Officer Guidance	37
10.2	User Guidance	37
10.2.1	Random Number Generator.....	37
10.2.2	AES GCM IV.....	37
10.2.3	AES-XTS	38
10.2.4	Key Usage and Management.....	38
10.3	Handling Self-Test Errors.....	38
11	Mitigation of Other Attacks.....	40
12	Acronyms, Terms and Abbreviations.....	41
13	References.....	42

List of Tables

Table 1: FIPS 140-2 Security Requirements.....	6
Table 2: Components of the cryptographic module	7
Table 3: Tested operational environments.....	9
Table 4: Ports and interfaces.	11
Table 5: Services in the FIPS-approved mode of operation.	12
Table 6: Services in the non-FIPS approved mode of operation.	14
Table 7: Approved cryptographic algorithms in this module.	18
Table 8: Non-Approved-but-allowed cryptographic algorithms in this module.	24
Table 9: Non-FIPS approved cryptographic algorithms in this module.....	24
Table 10: Lifecycle of keys and other Critical Security Parameters (CSPs).....	29
Table 11: Self-tests.....	35
Table 12: Conditional self-tests.....	36

List of Figures

Figure 1: Physical configurations of the module: (a) The WB50NBT microprocessor unit (MPU) with Microchip/Atmel ATSAMA5D31 microprocessor. (b) the 60 Series system on module (SOM) with Microchip/Atmel ATSAMA5D36 microprocessor.....	7
Figure 2: Block diagram with logical and physical cryptographic boundaries.....	9

1 Introduction

This document is the non-proprietary FIPS 140-2 Security Policy for the Summit Linux FIPS Core Crypto Module, software version 7.1, hardware version ATSAMA5D31, ATSAMA5D36. It contains the security rules under which the module must be operated and describes how this module meets the requirements as specified in FIPS 140-2 (Federal Information Processing Standards Publication 140-2) for a Security Level 1 module.

This Security Policy contains non-proprietary information. All other documentation submitted for FIPS 140-2 conformance testing and validation is proprietary and is releasable only under appropriate non-disclosure agreements.

1.1 Purpose of the Security Policy

There are three major reasons that a security policy is needed:

- It is required for FIPS 140-2 validation,
- It allows individuals and organizations to determine whether a cryptographic module, as implemented, satisfies the stated security policy, and
- It describes the capabilities, protection and access rights provided by the cryptographic module, allowing individuals and organizations to determine whether it will meet their security requirements.

1.2 Target Audience

This document is part of the package of documents that are submitted for FIPS 140 2 conformance validation of the module. It is intended for the following audience:

- Developers.
- FIPS 140-2 testing lab.
- The Cryptographic Module Validation Program (CMVP).
- Customers using or considering integration of the Summit Linux FIPS Core Crypto Module.

1.3 How this Security Policy was Prepared

The vendor has provided the non-proprietary Security Policy of the cryptographic module, which was further consolidated into this document by atsec information security together with other vendor-supplied documentation as guided by FIPS 140-2 IG G.9. In preparing the Security Policy document, the laboratory formatted the vendor-supplied documentation for consolidation without altering the technical statements therein contained. The further refining of the Security Policy document was conducted iteratively throughout the conformance testing, wherein the Security Policy was submitted to the vendor, who would then edit, modify, and add technical contents. The vendor would also supply additional documentation, which the laboratory formatted into the existing Security Policy, and resubmitted to the vendor for their final editing.

2 Cryptographic Module Specification

2.1 Module Overview

The Summit Linux FIPS Core Crypto Module (hereafter referred to as the “module”) is a Software-Hybrid module supporting FIPS 140-2 Approved cryptographic algorithms. The module is composed by a hardware component, the ARM-based Microchip/Atmel microprocessor, and software components comprised of a kernel and OpenSSL libraries. These libraries provide a C language application program interface (API) for use by other processes that require cryptographic functionality.

The module offers approved cryptographic functions in the FIPS mode for, among other uses:

- Algorithms for use in the Wi-Fi protocols CCMP and GCMP.
- Algorithms for use in the TLS protocol.
- Encryption and decryption for data at rest.

2.2 FIPS 140-2 Validation Scope

Table 1 shows the security level claimed for each of the eleven sections that comprise the FIPS 140-2 standard.

Table 1: FIPS 140-2 Security Requirements.

Security Requirements Section		Level
1	Cryptographic Module Specification	1
2	Cryptographic Module Ports and Interfaces	1
3	Roles and Services and Authentication	1
4	Finite State Machine Model	1
5	Physical Security	1
6	Operational Environment	1
7	Cryptographic Key Management	1
8	EMI/EMC	1
9	Self-Tests	1
10	Design Assurance	1
11	Mitigation of Other Attacks	N/A
Overall Level		1

2.3 Definition of the Cryptographic Module and its Cryptographic Boundaries

The Summit Linux FIPS Core Crypto Module is defined as a Software-Hybrid, Multi-chip Standalone module per the requirements within FIPS 140-2. The logical cryptographic boundary of the module consists of the embedded hardware AES cryptographic engine and NDRNG (entropy source) within the Microchip/Atmel microprocessor, the software component files (kernel, SummitSSL, and the fipscheck integrity test tool) and the integrity test HMAC files.

Figure 1 depicts the physical representations of the tested platforms as the top view of the circuit boards. The tested environments are further described in Section 2.4.

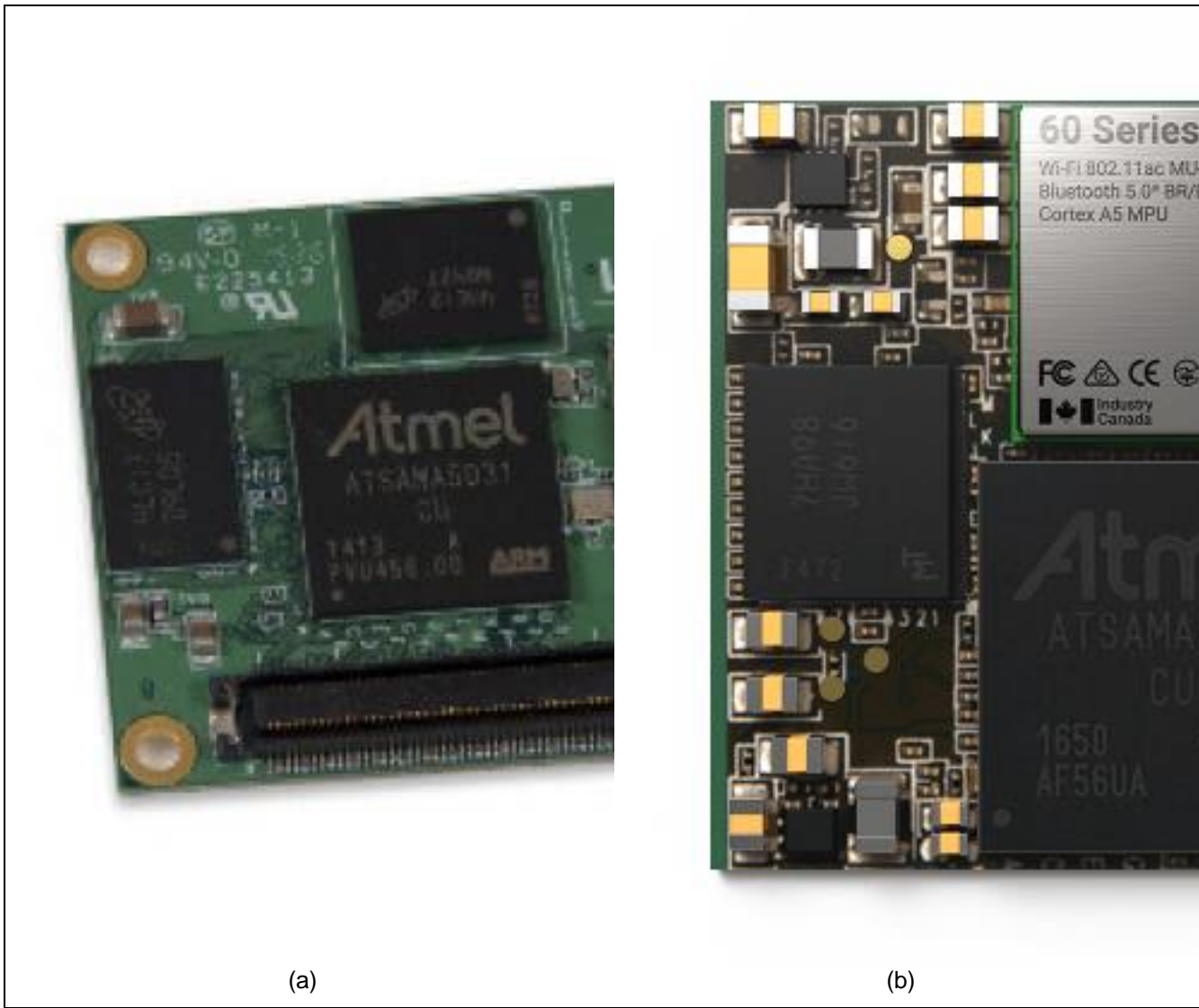

Figure 1: Physical configurations of the module: (a) The WB50NBT microprocessor unit (MPU) with Microchip/Atmel ATSAMA5D31 microprocessor. (b) the 60 Series system on module (SOM) with Microchip/Atmel ATSAMA5D36 microprocessor.

Table 2 lists the components that integrate the module. The software components of the module are of version 7.1.

Table 2: Components of the cryptographic module

Component	Description
Microchip/Atmel ATSAMA5D31 and ATSAMA5D36 ARM Cortex A5-based microprocessors	Hardware component with embedded AES engine and the NDRNG (individual versions for each test operational environment are listed in Table 3). This hardware component is only accessible to a user of the module through the kernel component interface.
SummitSSL library	Software shared library (based on OpenSSL version 1.0.2u), containing cryptographic algorithms.

Component	Description
	Filename: /usr/lib/libcrypto.so.1.0.0 HMAC (WB50 operational environment): 0d9ca92c2bcb6d92bbaf942328b6af0b7f69f54a5ca7c7e5e7babb4dca5e6a4c HMAC (60 Series operational environment): 0d9ca92c2bcb6d92bbaf942328b6af0b7f69f54a5ca7c7e5e7babb4dca5e6a4c
Summit Linux kernel	Kernel based on Linux kernel version 4.19, containing cryptographic algorithms. The kernel function as the interface to the hardware component; the hardware component cannot be accessed directly by a user of the module. Filename: /boot/Image.gz HMAC (WB50 operational environment): cc6913bf5b357605e9e5956ff37824566d5a1438a5af3bcdcf1639e19d830b32 HMAC (60 Series operational environment): 96bb34ef585f7e506dd29db445c547dea9a86c0a2e3723f40fc81c0676ca37a7
HMAC integrity files	Files containing HMAC values for integrity test of software components. Files: /usr/lib/fipscheck/Image.lzma.hmac /usr/lib/fipscheck/libcrypto.so.1.0.0.hmac /usr/lib/fipscheck/fipscheck.hmac /usr/lib/fipscheck/libfipscheck.so.1.hmac
fipscheck integrity test tool	Software tool that performs integrity test of the software components of the module. Files: /usr/bin/fipscheck (executable) /usr/lib/fipscheck/libfipscheck.so.1 (library) Executable HMAC (WB50 operational environment): 88adb74a99a4c9e2ae1d0332ac4af23ea5f9e2d40f9f4c6afe1afa8b041c6af4 Library HMAC (WB50 operational environment): 3603af6c623a3021547aa092ec1503be45d3c596d957a794c6ffd3b5b9f92bb1 Executable HMAC (60 Series operational environment): 88adb74a99a4c9e2ae1d0332ac4af23ea5f9e2d40f9f4c6afe1afa8b041c6af4 Library HMAC (60 Series operational environment): 3603af6c623a3021547aa092ec1503be45d3c596d957a794c6ffd3b5b9f92bb1

Figure 2 shows the block diagram of the module. The logical cryptographic boundary is indicated with orange blocks, distributed among hardware and software components. Blocks of another color do not belong to the logical boundary. Users of the module interact through the software API that are the logical interfaces mapping to the FIPS interfaces (data input and output, control input, status output). A dotted line encompasses the module's components that interface through the API.

In Figure 2, users of the module are exemplified by applications. These applications may reside within the NAND Flash memory or may reside outside (but still within the physical boundary), always interacting with the module's API.

The physical cryptographic boundary of the module is defined as the perimeter of the circuit board on which the module is installed (Section 2.4). The filesystem and operating system reside on NAND Flash memory within the physical boundary. No components are excluded from the requirements of FIPS 140-2.

Physical Boundary - WB50NBT, SU60-SOMC 60 Series

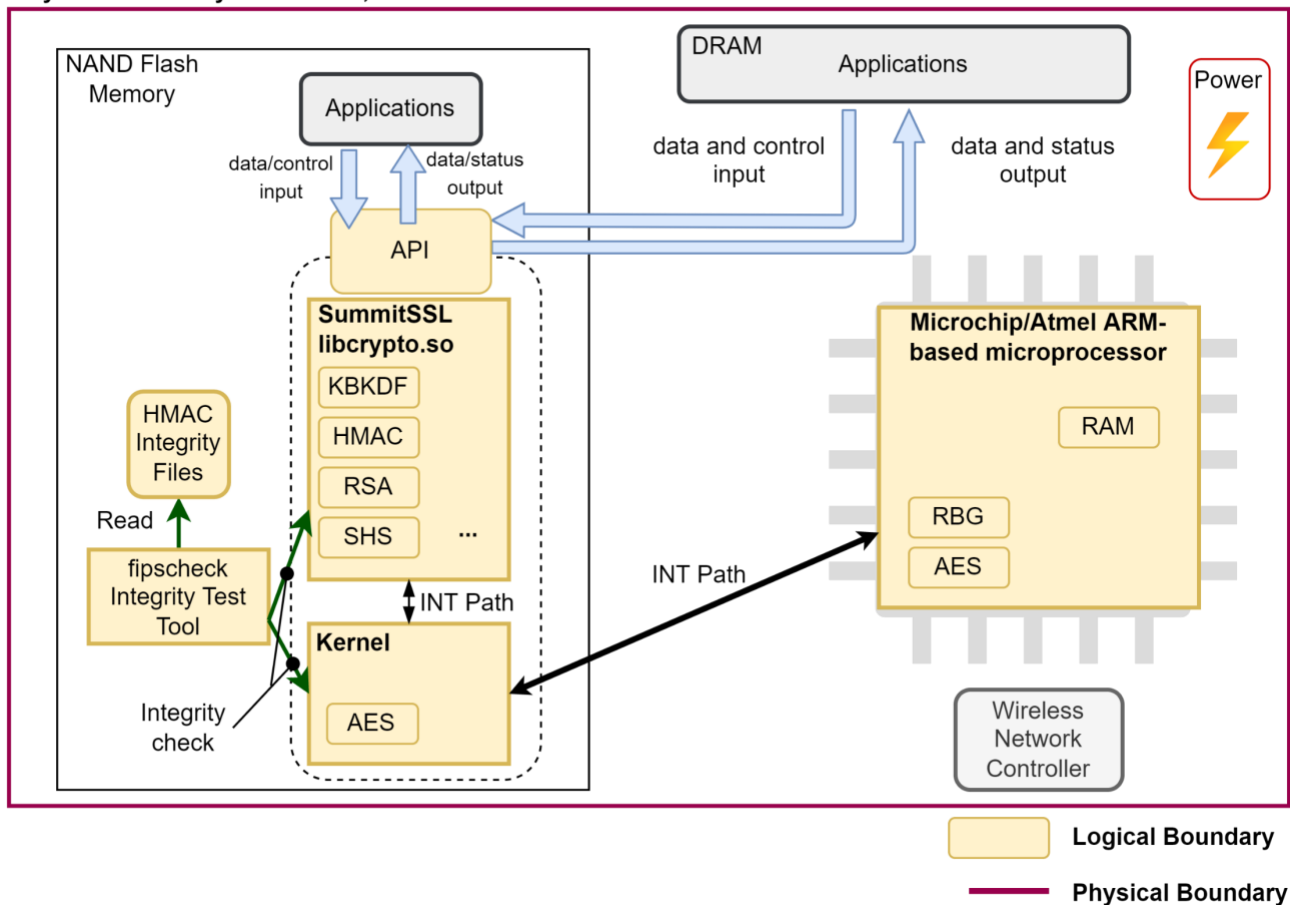

Figure 2: Block diagram with logical and physical cryptographic boundaries.

2.4 Tested Operational Environments

The module was tested on the operational environments listed in Table 3. These environments are composed of the WB50NBT microprocessor unit (MPU) with Microchip/Atmel ATSAMA5D31 microprocessor, and the SU60 SOMC 60 Series system on module (SOM) with Microchip/Atmel ATSAMA5D36 microprocessor, each of them mounted on a development board that provides the modules with power, filesystem, network, and other interfaces.

Table 3: Tested operational environments.

Operating System	Microprocessor	Hardware
Summit Linux 7.1	Microchip/Atmel ATSAMA5D31, ARM Cortex A5-based (ARMv7)	WB50NBT MPU (Microprocessor Unit)
Summit Linux 7.1	Microchip/Atmel ATSAMA5D36, ARM Cortex A5-based (ARMv7)	SU60-SOMC 60 Series SOM (System on Module)

2.5 Modes of Operation

The module supports two modes of operation.

- In "**FIPS mode**" (the Approved mode of operation), only approved or allowed security functions with sufficient security strength are offered by the module.
- In "**non-FIPS mode**" (the non-Approved mode of operation), non-approved security functions are offered by the module.

The module enters the operational mode after Power-On Self-Tests (POST) succeed. Once the module is operational, the mode of operation is implicitly assumed depending on the selected setting for the function `FIPS_mode_set()` invoked prior to the service, the security function invoked, and the security strength¹ of the cryptographic keys/curves chosen for the function or service.

In more detail, the module assumes the mode of operation in the following manner.

- Kernel Component and Hardware Component:
 - The mode is implicitly assumed depending on the security function invoked and the security strength of the cryptographic keys/curves chosen (see Table 5 and Table 6).
- SummitSSL Component:
 - If `FIPS_mode_set(0)` is called before the invocation of the service, the module implicitly assumes the non-FIPS mode of operation for any service.
 - If `FIPS_mode_set(1)` is called before the invocation of the service:
 - If the service is strictly listed in Table 5 and is using strictly algorithms, keys/curves listed in Table 7 and Table 8, then the module assumes the FIPS-approved mode of operation.
 - Otherwise, the module assumes the non-FIPS mode of operation.

If the POST or the Conditional Tests fail (Section 9), the module goes into the error state. The status of the module can be determined by the availability of the module. If the module is available, then it has passed all self-tests. If the module is unavailable, it is because any self-test failed, and the module has transitioned to the error state.

The module does not share keys and other Critical Security Parameters (CSPs) that are used or stored in FIPS mode with functions in the non-FIPS mode, and vice versa.

¹ See Section 5.6.1 in [SP800-57] for a definition of "security strength".

3 Module Ports and Interfaces

The module provides cryptographic services and an application program interface (API). The kernel component serves as the API to the hardware component.

The physical ports of the hardware component of the module are registers in the Microchip/Atmel microprocessor, within the logical boundary of the module. These registers hold the data for API parameters. The data flow in and out of registers via UART or SPI (Serial Peripheral Interface) interfaces of the Microchip/Atmel microprocessor. The logical interfaces are represented by the API through which applications request services and obtain responses. The API represent the logical interfaces with both the software components and the hardware component of the module (which can only be accessed through the software API by a user of the module).

Table 4 summarizes the FIPS logical interfaces and their mappings to software interfaces and physical ports.

Table 4: Ports and interfaces.

Logical Interface	Description
Data Input	API input parameters for data
Data Output	API output parameters for data
Control Input	API function calls, API input parameters for control.
Status Output	API return codes, API output parameters for status.
Power Input	The hardware component of the module receives power from the circuit board on which the module is installed. The power input is not applicable for the software components.

The Data Input interface consists of the input parameters of the API functions. For the hardware component, the input data is received from the Serial Peripheral Interface (SPI) or Universal Asynchronous Receiver/Transmitter (UART) of the Microchip/Atmel microprocessor.

The Data Output interface consists of the output parameters of the API functions. For the hardware component, the output data leaves the physical boundary of the Microchip/Atmel microprocessor via its SPI or UART interfaces.

The Control Input interface consists of the API function calls and the input parameters used to control the behavior of the module. For the hardware component, the API function calls are handled by the system scheduler as interrupts. The control input enters the registers of the module via its SPI or UART interfaces.

The Status Output interface includes the return code of the API functions and the status sent through output parameters. For the hardware component, the return code or status output may reside in the registers of the module or are sent out of the microprocessor via its SPI or UART interfaces.

The Power Input, applicable only to the hardware component of the module, is represented by the power supply port of the Atmel/Microchip microprocessor. Power is supplied by the circuit board that supports the microprocessor.

4 Roles, Services and Authentication

4.1 Roles

The module supports the following roles:

- **User role:** performs all services (in both FIPS mode and non-FIPS mode of operation), except module installation and configuration.
- **Crypto Officer role:** performs module installation and configuration.

The User and Crypto Officer roles are implicitly assumed by the entity accessing the module's services. In other words, by invoking a specific service offered by the module, the role is implicitly assumed by the entity according to the service that was invoked by that entity, as the service is defined to one or the other role.

4.2 Services

The module provides services to entities who assume one of the available roles. Table 5 and Table 6 depict all services that are described with more detail in the developer documentation. The tables also list the roles allowed to invoke each service, and the keys and Critical Security Parameters (CSPs) involved and how these keys and CSPs are accessed.

The module does not implement the GCMP, CCMP, or TLS protocols, but rather the cryptographic algorithms (such as the TLS KDF and SP800-108 KDF) that can be used to implement those protocols by applications.

The tables use the following convention when specifying the access permissions that the service has for each CSP or key. The applicable abbreviations are shown within parentheses.

- **Create (C):** the user entity can create a new CSP.
- **Read (R):** the user entity can read the CSP.
- **Update (U):** the user entity can write a new value to the CSP.
- **Zeroize (Z):** the user entity can zeroize the CSP.
- **N/A:** the user entity does not access any CSP or key during its operation.

For the "Role" column, U indicates the User role, and CO indicates the Crypto Officer role. An X marks which role has access to that service.

4.2.1 Services in the FIPS-Approved Mode of Operation

Table 5 provides a full description of FIPS Approved services and the non-Approved but Allowed services provided by the module in the FIPS-approved mode of operation.

Table 5: Services in the FIPS-approved mode of operation.

Service	Service Description and Algorithms	Role		Keys and CSPs	Access Types
		U	CO		
SummitSSL Component, Services with FIPS_mode_set(1)					
Symmetric Encryption/Decryption	Encrypts or decrypts a block of data using AES.	X		AES Key	R
RSA Key Generation	Generate RSA asymmetric keys using DRBG.	X		RSA public/private keys	C, R
DSA Key Generation	Generate DSA asymmetric keys using DRBG.	X		DSA public/private keys	C, R

Service	Service Description and Algorithms	Role		Keys and CSPs	Access Types
		U	CO		
ECDSA Key Generation	Generate ECDSA asymmetric keys using DRBG.	X		ECDSA public/private keys	C, R
RSA Digital Signature Generation and Verification	Sign and verify signature operations for RSA PKCS#1v1.5, RSA-PSS and X9.31.	X		RSA public/private keys	R
DSA Digital Signature Generation and Verification	Sign and verify signature operations for DSA.	X		DSA public/private keys	R
ECDSA Digital Signature Generation and Verification	Sign and verify signature for ECDSA.	X		ECDSA public/private keys	R
TLS Key Derivation	Derive keying material for use in the TLS protocol. KDF in TLS v1.0/1.1, TLS v1.2 (SP800-135).	X		Pre-master secret, master secret, derived key (AES, HMAC), KDF internal state	C, R, U
Key-Based Key Derivation (KBKDF)	SP800-108 KDF in Counter mode. Derive keys for establishment of secure communication channels.	X		Key derivation key and derived keys (AES, HMAC), 802.11 pre-shared key (PSK), 802.11 pairwise master key (PMK), 802.11 KDF internal state, 802.11 Temporal Keys, 802.11 MIC keys (KCK), 802.11 Key Encryption Key (KEK), EAP-TLS MSK, EAP-TTLS MSK, EAP-PEAP MSK	C, R, U
Diffie-Hellman Shared Secret Computation	Establish a shared secret. KAS-FFC-SSC	X		Diffie-Hellman public/private keys, shared secret, pre-master secret	C, R
EC Diffie-Hellman Shared Secret Computation	Establish a shared secret. KAS-ECC-SSC	X		EC Diffie-Hellman public/private keys, shared secret, pre-master secret	C, R
Key Wrapping with RSA	Encapsulates and decapsulates a key using RSA encrypt/decrypt primitives	X		RSA public/private keys. Wrapped key.	C, R, U
Key Wrapping with Symmetric Algorithms	Wrap and unwrap keys with AES-KW, AES-KWP	X		AES keys (key wrapping key). Wrapped key.	C, R, U
Certificate Management	Management of key properties within certificates.	X		RSA, DSA, and ECDSA public/private keys associated to an X.509 certificate	R, U

Service	Service Description and Algorithms	Role		Keys and CSPs	Access Types
		U	CO		
Message Authentication Code (MAC)	Authenticate and verify authentication of data using HMAC-SHA-1, HMAC-SHA2-224, HMAC-SHA2-256, HMAC-SHA2-384, HMAC-SHA2-512	X		HMAC Key	R
	Authenticate and verify authentication of data using CMAC and GMAC with AES-128, AES-192, AES-256.	X		AES Key	R
Message Digest	Hash a block of data with SHS. SHA-1, SHA2-224, SHA2-256, SHA2-384, SHA2-512	X		None	N/A
Random Number Generation	Generate random numbers based on the SP 800-90A DRBG.	X		Entropy input string, internal state, seed	C, R, U
Kernel and Hardware Components					
Symmetric Encryption/Decryption	Encrypts or decrypts a block of data using AES.	X		AES Key	R
Other FIPS-related Services					
Show Status	Show status of the module state	X		None	N/A
Self-Test	Initiate power-on self-tests	X		None	N/A
Zeroize	Zeroize all critical security parameters	X		All keys and CSPs	Z
Module Installation	Installation of the module		X	None	N/A
Module Configuration	Configuration of the module		X	None	N/A

4.2.2 Services in the Non-FIPS-Approved Mode of Operation

Table 6 presents the services only available in non-FIPS-approved mode of operation.

Table 6: Services in the non-FIPS approved mode of operation.

Service	Service Description and Algorithms	Role		Keys	Access Types
		U	CO		
SummitSSL Component, Services with FIPS_mode_set(0)					
Symmetric Encryption/Decryption	Encrypts or decrypts a block of data using AES.	X		AES Key	R

Service	Service Description and Algorithms	Role		Keys	Access Types
		U	CO		
RSA Key Generation	Generate RSA asymmetric keys using DRBG.	X		RSA public/private keys	C, R
DSA Key Generation	Generate DSA asymmetric keys using DRBG.	X		DSA public/private keys	C, R
ECDSA Key Generation	Generate ECDSA asymmetric keys using DRBG.	X		ECDSA public/private keys	C, R
RSA Digital Signature Generation and Verification	Sign and verify signature operations for RSA PKCS#1v1.5, RSA-PSS and X9.31.	X		RSA public/private keys	R
DSA Digital Signature Generation and Verification	Sign and verify signature operations for DSA.	X		DSA public/private	R
ECDSA Digital Signature Generation and Verification	Sign and verify signature for ECDSA.	X		ECDSA public/private keys	R
TLS Key Derivation	Derive keying material for use in the TLS protocol. KDF in TLS v1.0/1.1, TLS v1.2 (SP800-135).	X		Pre-master secret, master secret, derived key (AES, HMAC), KDF internal state	C, R, U
Key-Based Key Derivation (KBKDF)	SP800-108 KDF in Counter mode. Derive keys for establishment of secure communication channels.	X		Key derivation key and derived keys (AES, HMAC), 802.11 pre-shared key (PSK), 802.11 pairwise master key (PMK), 802.11 KDF internal state, 802.11 Temporal Keys, 802.11 MIC keys (KCK), 802.11 Key Encryption Key (KEK), EAP-TLS MSK, EAP-TTLS MSK, EAP-PEAP MSK	C, R, U
Diffie-Hellman Shared Secret Computation	Establish a shared secret. KAS-FFC-SSC	X		Diffie-Hellman public/private keys, shared secret, pre-master secret	C, R
EC Diffie-Hellman Shared Secret Computation	Establish a shared secret. KAS-ECC-SSC	X		EC Diffie-Hellman public/private keys, shared secret, pre-master secret	C, R
Key Wrapping with RSA	Encapsulates and decapsulates a key using RSA encrypt/decrypt primitives	X		RSA public/private keys. Wrapped key	C, R, U

Service	Service Description and Algorithms	Role		Keys	Access Types
		U	CO		
Key Wrapping with Symmetric Algorithms	Wrap and unwrap keys with AES-KW, AES-KWP	X		AES keys (key wrapping key). Wrapped key	C, R, U
Message Authentication Code (MAC)	Authenticate and verify authentication of data using HMAC-SHA-1, HMAC-SHA2-224, HMAC-SHA2-256, HMAC-SHA2-384, HMAC-SHA2-512	X		HMAC Key	R
	Authenticate and verify authentication of data using CMAC and GMAC with AES-128, AES-192, AES-256	X		AES Key	R
Random Number Generation	Generate random numbers based on the DRBG.	X		Entropy input string, internal state, seed	C, R, U
SummitSSL Component, Services with FIPS_mode_set(0) or FIPS_mode_set(1)					
Symmetric Encryption/Decryption	Encrypts or decrypts using non-Approved algorithms or key sizes not listed in Table 7	X		Triple-DES, Camellia, CAST, DES, IDEA, RC2, RC4, RC5 keys	R
RSA, DSA, ECDSA Key Generation	Generation of non-Approved RSA, DSA and ECDSA keys	X		RSA key < 2048 bits DSA keys or ECDSA curves not listed in Table 7	C, R, U
Digital Signature Generation and Verification	Sign or verify operations with non-Approved RSA, DSA, or ECDSA key lengths or curves	X		RSA key < 2048 DSA keys or ECDSA curves not listed in Table 7 Signature Generation with SHA-1	R
TLS Key Derivation	Derive keying material for cryptographic function outside of a TLS protocol context, or using SHS and HMAC algorithms not listed in Table 7 or not in conformance with SP800-135	X		Pre-master secret, master secret, derived key (AES, HMAC)	C, R, U
Key Wrapping with RSA	Encrypts or decrypts using non-Approved RSA key size	X		RSA key pair Wrapped key	C, R, U
Diffie-Hellman Shared Secret Computation	Establish a shared secret.	X		Diffie-Hellman key < 2048 bits, shared secret	C, R

Service	Service Description and Algorithms	Role		Keys	Access Types
		U	CO		
	KAS-FFC-SSC				
EC Diffie-Hellman Shared Secret Computation	Establish a shared secret. KAS-ECC-SSC	X		EC Diffie-Hellman CSPSs with curves not listed in Table 7 or Table 8, shared secret	C, R
Random Number Generation	Generation of random numbers using the ANSI X9.31 PRNG	X		seed, seed key, internal state	C, R, U
Message Digest	Hashing using non-Approved hash functions that include MD2, MD4, MD5, MDC2, RIPEMD, Whirlpool	X		None	N/A
J-PAKE Key Agreement	Password authenticated key agreement using J-PAKE	X		J-PAKE key pair	C, R
Kernel Component					
Symmetric Encryption/Decryption	Encrypts or decrypts using non-Approved algorithms	X		DES, RC4, Triple-DES keys	R
Digital Signature Generation and Verification	Sign or verify operations using RSA	X		RSA key pair	R
Key Wrapping with RSA	Encrypts or decrypts using RSA	X		RSA key pair Wrapped key	C, R, U
Diffie-Hellman Shared Secret Computation	Establish a shared secret. KAS-FFC-SSC	X		Diffie-Hellman public/private keys, shared secret	C, R
EC Diffie-Hellman Shared Secret Computation	Establish a shared secret. KAS-ECC-SSC	X		EC Diffie-Hellman public/private keys, shared secret	C, R
Message Authentication Code (MAC)	Authenticate and verify authentication of data using HMAC-SHA-1, HMAC-SHA2-224, HMAC-SHA2-256, HMAC-SHA2-384, HMAC-SHA2-512, HMAC-SHA3-224, HMAC-SHA3-256, HMAC-SHA3-384, HMAC-SHA3-512	X		HMAC Key	R
	Authenticate and verify authentication of data	X		Triple-DES Key	R

Service	Service Description and Algorithms	Role		Keys	Access Types
		U	CO		
	using CMAC with Triple-DES				
Message Digest	Hashing using SHA-1, SHA2-224, SHA2-256, SHA2-384, SHA2-512, SHA3-224, SHA3-256, SHA3-384, SHA3-512, MD5 hash functions	X		None	N/A
Random Number Generation	Generate random numbers based on the DRBG.	X		Entropy input string, internal state, seed	C, R, U
Hardware Component					
Message Digest	Hashing using SHA-1, SHA2-224, SHA2-256, SHA2-384, SHA2-512	X		None	N/A
Symmetric Encryption/Decryption	Encrypts or decrypts using DES, Triple-DES	X		DES, Triple-DES keys	R

4.3 Algorithms

The module implements cryptographic algorithms that are used by the services provided by the module. The cryptographic algorithms that are approved to be used in the FIPS mode of operation are tested and validated by the CAVP.

Table 7, Table 8 and Table 9 present the cryptographic algorithms in specific modes of operation. These tables include the CAVP certificates for different implementations, the algorithm name, respective standards, the available modes, key sizes, or curves wherein applicable, and usage. Information from certain columns may be applicable to more than one row.

4.3.1 Approved Algorithms

Table 7 lists the cryptographic algorithms that are approved to be used in the FIPS mode of operation. in this module. For the kernel component, the entries include the algorithm driver name that is approved for the respective algorithm.

Note that the algorithm certificates may include algorithms that are not available as approved in this module.

Table 7: Approved cryptographic algorithms in this module.

Algorithm	Standard	Mode/Method	Lengths, Curves, Moduli (bits)	Use	CAVP Cert# ²
SummitSSL Component					
AES	FIPS197 SP800-38A	CBC, CFB1, CFB8, CFB128, CTR, ECB, OFB	128, 192 and 256 bits	Data Encryption and Decryption	#C1595 #C1612

² Not all algorithms validated by the CAVP are implemented in the module.

Algorithm	Standard	Mode/Method	Lengths, Curves, Moduli (bits)	Use	CAVP Cert# ²
	FIPS197 SP800-38B	CMAC	128, 192 and 256 bits	MAC Generation and Verification	
	FIPS197 SP800-38C	CCM	128, 192 and 256 bits	Data Encryption and Decryption	
	FIPS197 SP800-38D	GCM	128, 192 and 256 bits	Data Encryption and Decryption	
	FIPS197 SP800-38D	GMAC	128, 192 and 256 bits	MAC Generation and Verification	
	FIPS197 SP800-38E	XTS	128, 256 bits	Data Encryption and Decryption	
	FIPS197 SP800-38F	KW, KWP	128, 192 and 256 bits	Key Wrapping and Unwrapping	
DSA	FIPS 186-4	n/a	L=2048, N=224; L=2048, N=256; L=3072, N=256	Key Generation	#C1595 #C1612
		P/Q Probable, G Unverifiable SHA2-224, SHA2-256, SHA2-384, SHA2-512	L=2048, N=224	Domain Parameter Generation	
		P/Q Probable, G Unverifiable SHA2-256, SHA2-384, SHA2-512	L=2048, N=256; L=3072, N=256		
		SHA2-224, SHA2-256, SHA2-384, SHA2-512	L=2048, N=224; L=2048, N=256; L=3072, N=256	Signature Generation	
		P/Q Probable, G Unverifiable SHA-1, SHA2-224, SHA2-256, SHA2-384, SHA2-512	L=1024, N=160	Domain Parameter Verification	

Algorithm	Standard	Mode/Method	Lengths, Curves, Moduli (bits)	Use	CAVP Cert# ²
		P/Q Probable, G Unverifiable SHA2-224, SHA2-256, SHA2-384, SHA2-512	L=2048, N=224		
		P/Q Probable, G Unverifiable SHA2-256, SHA2-384, SHA2-512	L=2048, N=256; L=3072, N=256		
		SHA-1, SHA2-224, SHA2-256, SHA2-384, SHA2-512	L=1024, N=160; L=2048, N=224; L=2048, N=256; L=3072, N=256	Signature Verification	
DRBG	SP800-90A	CTR_DRBG AES128, AES192, AES256 with/without DF, with/without PR	n/a	Random Number Generation	#C1595 #C1612
ECDSA	FIPS186-4		B-233, B-283, B-409, B-571, K-233, K-283, K-409, K-571, P-224, P-256, P-384, P-521	Key Generation	#C1595 #C1612
		SHA2-224, SHA2-256, SHA2-384, SHA2-512	B-233, B-283, B-409, B-571, K-233, K-283, K-409, K-571, P-224, P-256, P-384, P-521	Signature Generation	
		n/a	B-233, B-283, B-409, B-571, K-163, K-233, K-283, K-409, K-571, P-192, P-224, P-256, P-384, P-521	Public Key Verification	

Algorithm	Standard	Mode/Method	Lengths, Curves, Moduli (bits)	Use	CAVP Cert# ²
		SHA-1, SHA2-224, SHA2-256, SHA2-384, SHA2-512	B-233, B-283, B-409, B-571, K-163, K-233, K-283, K-409, K-571, P-192, P-224, P-256, P-384, P-521	Signature Verification	
KAS-FFC-SSC SP800-56Ar3	SP800-56Ar3	FFC dhEphem scheme	ffdhe2048, ffdhe3072, ffdhe4096, ffdhe6144, ffdhe8192, MODP- 2048, MODP-3072, MODP-4096, MODP-6144, MODP-8192	Diffie-Hellman Shared Secret Computation	#A1487
KAS-ECC-SSC SP800-56Ar3	SP800-56Ar3	EphemeralUnified scheme	B-233, B-283, B-409, B-571, K-233, K-283, K-409, K-571, P-224, P-256, P-384, P-521	EC Diffie- Hellman Shared Secret Computation	#A1490
Safe Primes Key Generation	SP800-56Ar3	n/a	ffdhe2048, ffdhe3072, ffdhe4096, ffdhe6144, ffdhe8192, MODP- 2048, MODP-3072, MODP-4096, MODP-6144, MODP-8192	Key Generation	#A1487
Safe Primes Key Verification	SP800-56Ar3	n/a	ffdhe2048, ffdhe3072, ffdhe4096, ffdhe6144, ffdhe8192, MODP- 2048, MODP-3072, MODP-4096, MODP-6144, MODP-8192	Key Verification	#A1487
HMAC	FIPS198-1	SHA-1, SHA2-224, SHA2-256, SHA2-384, SHA2-512	112 bits or greater	Message Authentication Code	#C1595 #C1612

Algorithm	Standard	Mode/Method	Lengths, Curves, Moduli (bits)	Use	CAVP Cert# ²
KDF TLS v1.0/1.1, v1.2	SP800-135	TLS v1.0/1.1: SHA-1 TLS v1.2: SHA2-256, SHA2-384, SHA2-512	n/a	Key Derivation	#C1595 #C1612
KBKDF SP800-108	SP800-108	Counter Mode HMAC-SHA2-256, HMAC-SHA2-384, HMAC-SHA2-512	n/a	Key Derivation	#C1595 #C1612
RSA	FIPS186-4	B.3.3 Random Probably Primes Random Public Exponent	2048, 3072, 4096 bits	Key Pair Generation	#C1595 #C1612 #A2150
		X9.31 with SHA2-256, SHA2-384, SHA2-512	2048, 3072, 4096 bits	Digital Signature Generation	
		PKCS#1v1.5 and PSS with SHA2-224, SHA2-256, SHA2-384, SHA2-512	2048, 3072, 4096 bits		
		X9.31 with SHA-1, SHA2-256, SHA2-384, SHA2-512	1024, 2048, 3072, 4096 bits	Signature Verification	
		PKCS#1v1.5 and PSS with SHA-1, SHA2-224, SHA2-256, SHA2-384, SHA2-512	1024, 2048, 3072, 4096 bits		
SHS	FIPS180-4	SHA-1, SHA2-224, SHA2-256, SHA2-384, SHA2-512	N/A	Message Digest	#C1595 #C1612
KTS	SP800-38F	AES-GCM	128, 256 bits	Key Wrapping within TLS	#C1595 #C1612

Algorithm	Standard	Mode/Method	Lengths, Curves, Moduli (bits)	Use	CAVP Cert# ²
	SP800-38F	AES-KW, AES-KWP	128, 192, 256 bits	Key Wrapping	#C1595 #C1612
CKG	IG D.12 SP800-133	Asymmetric keys (Section 7.2)	N/A	N/A	Vendor Affirmed
Kernel and Hardware Components					
AES	FIPS197 SP800-38A	CBC <i>(driver atmel-cbc-aes)</i> CTR <i>(driver atmel-ctr-aes)</i> ECB <i>(driver atmel-ecb-aes)</i> Modes utilized from the hardware component.	128, 192 and 256 bits	Data Encryption and Decryption	#C1588 #C1591
	FIPS197 SP800-38B	CMAC <i>(driver atmel-cmac-aes)</i> Uses AES-CTR and AES-CBC from hardware component.	128, 192 and 256 bits	MAC Generation and Verification	
	FIPS197 SP800-38C	CCM <i>(driver atmel-ccm-aes)</i> Uses AES-CTR and AES-CBC from hardware component.	128, 192 and 256 bits	Data Encryption and Decryption	
	FIPS197 SP800-38D	GCM <i>(driver gcmap(gcm_base(atmel-ctr-aes,ghash-generic))</i>	128, 192 and 256 bits	Data Encryption and Decryption	
	SP800-38A Addendum	CBC-CS3 <i>(driver cts(atmel-cbc-aes))</i>	128, 192 and 256 bits	Data Encryption and Decryption	#A2136
	FIPS197 SP800-38E	XTS <i>(driver xts(atmel-ecb-aes))</i>	128, 256 bits	Data Encryption and Decryption	#C1589 #C1590

Algorithm	Standard	Mode/Method	Lengths, Curves, Moduli (bits)	Use	CAVP Cert# ²
KTS	SP800-38F	AES-GCM	128, 256 bits	Key Wrapping	#C1588 #C1591

4.3.2 Non-Approved-but-Allowed Algorithms

Table 8 lists the non-Approved-but-Allowed cryptographic algorithms provided by this module that are allowed to be used in the FIPS mode of operation in this module.

Table 8: Non-Approved-but-allowed cryptographic algorithms in this module.

Algorithm	Usage
RSA Key Wrapping with key size between 2048 bits and 15360 bits (or more)	Key wrapping, key establishment methodology provides between 112 and 256 bits of encryption strength. Allowed by IG D.9.
NDRNG	Used for seeding the SP 800-90A DRBG.

4.3.3 Non-Approved Algorithms

Table 9 lists the cryptographic algorithms that are not allowed to be used in the FIPS mode of operation in this module. Use of any of these algorithms (and corresponding services in Table 6) will implicitly switch the module to the non-Approved mode.

Table 9: Non-FIPS approved cryptographic algorithms in this module.

Algorithm	Usage
SummitSSL Component	
ANSI X9.31 RNG	Random number generation
Camellia	Encryption/decryption
CAST	Encryption/decryption
DES	Encryption/decryption
Diffie-Hellman	Shared secret computation using keys of length not listed in Table 7.
DSA	Parameter/key generation/signature generation and verification with keys not listed in Table 7
EC Diffie-Hellman	Shared secret computation using curves not listed in Table 7 or Table 8
ECDSA	Key generation/signature generation and verification with curves not listed in Table 7
IDEA	Encryption/decryption
J-PAKE	Password Authenticated Key Exchange

Algorithm	Usage
MD2	Message digest
MD4	Message digest
MD5	Message digest
MDC2	Message digest
RC2	Encryption/decryption
RC4	Encryption/decryption
RC5	Encryption/decryption
RIPEMD	Message digest
RSA	Key generation/signature generation, and key wrapping with keys of length less than 2048 bits
SHA-1	When used in signature generation
Triple-DES	Encryption/decryption
Whirlpool	Message digest
Kernel Component	
Triple-DES	Encryption/decryption
DES	
RC4	
RSA	Encryption/decryption
	Signature Generation/Verification
Diffie-Hellman	Shared secret computation
EC Diffie-Hellman	Shared secret computation
HMAC-SHA-1, HMAC-SHA2-224, HMAC-SHA2-256, HMAC-SHA2-384, HMAC-SHA2-512, HMAC-SHA3-224, HMAC-SHA3-256, HMAC-SHA3-384, HMAC-SHA3-512	Keyed-hash message authentication code
Triple-DES-CMAC	
SHA-1, SHA2-224, SHA2-256, SHA2-384, SHA2-512,	Message digest

Algorithm	Usage
SHA3-224, SHA3-256, SHA3-384, SHA3-512,	
MD5	
DRBG	Random Number Generation
Hardware Component	
SHA-1, SHA2-224, SHA2-256, SHA2-384, SHA2-512	Message digest
Triple-DES	Encryption/decryption
DES	

4.4 Operator Authentication

The module does not support operator authentication mechanisms. The role of the operator is implicitly assumed based on the service requested.

5 Physical Security

The module is a software-hardware hybrid module. The module contains standard integrated circuits with a uniform exterior material and standard connectors. The module is enclosed within a production-grade enclosure with components that include standard passivation techniques (e.g., a conformal coating applied over the module's circuitry to protect against environmental or other physical damage) conformant to the Level 1 requirements for physical security.

The physical security requirements do not apply to the software components of the module.

6 Operational Environment

6.1 Applicability

The module operates in a modifiable operational environment per FIPS 140-2 Security Level 1 specifications. The module runs on the Summit Linux operating system executing on the hardware specified in Section 2.4.

6.2 Policy

The operating system is restricted to a single operator mode of operation (i.e., concurrent operators are explicitly excluded by the operating system; the operating system provides context and memory space separation for distinct processes).

The application that makes calls to the modules is the single user of the modules, even when the application is serving multiple clients.

7 Cryptographic Key Management

This section describes the cryptographic keys and CSPs managed by the module, and how this management is performed during the keys and CSPs life cycle.

Table 10 summarizes the keys and other CSPs that are used by the cryptographic services implemented in the module. The table lists the use of each key/CSP and, as applicable, how they are generated or established, and their method of entry and output of the module. For all keys and CSPs, the storage is in RAM in plaintext. The zeroization method is described in Section 7.5.

Table 10: Lifecycle of keys and other Critical Security Parameters (CSPs).

Name	Use	Generation/Establishment	Entry and Output	Type
AES Key	Encryption, decryption. MAC generation and verification for CMAC. Key wrapping.	Provided by the user entity.	Entered via API input parameter. No output.	AES key, all modes per Table 7. Length: 128, 192 and 256 bits for all modes except XTS: XTS accepts lengths of 128 and 256 bits.
AES Derived Key	Encryption, decryption. MAC generation and verification for CMAC. Key wrapping.	Derived during 802.11 authentication using 802.11 SP800-108 KDF. Derived by SP800-135 KDF.	No entry. Output via API output parameters in plaintext.	AES key (CBC, CCM, GCM) with length 128 and 256 bits (defined by TLS ciphersuite, CCMP, or GCMP).
HMAC Key	MAC generation and verification	Provided by the user entity.	Entered via API input parameter. No output.	HMAC keys of length > 112 bits.
HMAC Derived Key	MAC generation and verification	Derived during 802.11 authentication using 802.11 SP800-108 KDF. Derived by SP800-135 KDF.	No entry. Output via API output parameters in plaintext.	HMAC key of length defined by ciphersuite, CCMP, or GCMP.
RSA public and private key	RSA signature generation and verification. Key wrapping.	Keys are generated using FIPS 186-4 and the random value used in the key generation is obtained from SP800-90A DRBG.	Entered via API input parameter or generated by module. Output via API output parameters in plaintext.	RSA keys of length 1024, 2048, 3072 bits (or more as allowed for key wrapping)
DSA public and private key	DSA signature generation and verification.	Keys are generated using FIPS 186-4 and the random value used in the key generation is	Entered via API input parameter or generated by module.	DSA keys of length 1024, 2048, 3072 bits

Name	Use	Generation/Establishment	Entry and Output	Type
		obtained from SP800- 90A DRBG.	Output via API output parameters in plaintext.	
ECDSA public and private key	ECDSA signature generation and verification.	Keys are generated using FIPS 186-4 and the random value used in the key generation is obtained from SP800- 90A DRBG.	Entered via API input parameter or generated by module. Output via API output parameters in plaintext.	ECDSA keys for all supported curves in Table 7.
Diffie-Hellman public and private key	Shared secret computation.	Keys are generated using SP800-56Arev3 methods and the random value used in the key generation is obtained from SP800- 90A DRBG.	Entered via API input parameter or generated by module. Output via API output parameters in plaintext.	Key lengths 2048 bits and 15360 bits (or more).
EC Diffie-Hellman public and private key	Shared secret computation.	Keys are generated using SP800-56Arev3 methods and the random value used in the key generation is obtained from SP800- 90A DRBG.	Entered via API input parameter or generated by module. Output via API output parameters in plaintext.	All supported curves in Table 7.
Shared Secret	Computation of shared secret	Generated during the shared secret computation when using Diffie-Hellman or EC Diffie-Hellman	Entered via API input parameter or generated by module. Output via API output parameters in plaintext.	Length defined per user application.
Pre-master secret	Establishment of encrypted session.	Generated during the shared secret computation when using Diffie-Hellman or EC Diffie-Hellman key exchange. Generated by TLS client as output from DRBG when using RSA key exchange.	Entry: if received by module as TLS server, wrapped with server's public RSA key; otherwise no entry. Output: if generated by module as TLS client, wrapped with server's public RSA key; otherwise, no output.	Length defined per user application ciphersuite.
Master secret	Establishment of encrypted session.	Derived from pre-master secret.	N/A	384 bits.

Name	Use	Generation/Establishment	Entry and Output	Type
Entropy input string	Entropy input strings used to compose the seed to the DRBG.	Obtained from NDRNG (entropy source).	N/A	384 bits.
DRBG Internal state (V, Key) and seed	Used to generate random bits.	During DRBG initialization and reseed.	N/A	Internal state and seed.
RSA, ECDSA, DSA private key associated to an X.509 certificate, and X.509 (public) certificates	Client and server authentication during TLS exchange.	Provided by the user entity.	Entered via API parameters. The certificate can exit the module via TLS protocol.	RSA, DSA, ECDSA keys and certificates.
802.11 Pre-shared key (PSK)	Used for pre-shared key authentication and session key establishment, as well as for 802.11 KDF	N/A	Manually distributed, electronically entered in plaintext. No exit.	Up to 256 bits of length.
802.11 Pairwise Master Key (PMK)	Used for pre-shared key authentication and session key establishment, as well as for 802.11 KDF	N/A	Manually distributed, electronically entered in plaintext, or derived from the PSK or EAP parameters. No exit.	256 or 384 bits.
802.11 KDF Internal State	Used for SP 800-108 KDF to calculate the WPA2 session keys	SP 800-108 KDF	N/A	Internal state of the KDF.
802.11 Temporal Keys	AES-CCM or AES-GCM keys used for session encryption/decryption	SP 800-108 KDF	N/A	AES-CCM, AES-GCM of 128 or 256 bits.
802.11 MIC keys (KCK)	Key confirmation keys (KCK) used for message authentication during session establishment	SP 800-108 KDF	N/A	128 or 192 bits.
802.11 Key Encryption Key (KEK)	Used for AES Key Wrapping of the 802.11 Group	SP 800-108 KDF	N/A	128 or 256 bits.

Name	Use	Generation/Establishment	Entry and Output	Type
	Temporal Key (GTK)			
802.11 Group Temporal Key (GTK)	802.11 session key for broadcast communications	Established by key transport: wrapped with 802.11 KEK (IG D.9).	Entered via key transport: wrapped with 802.11 KEK. No exit.	128, 256 bits.
TLS KDF Internal State	Values of the TLS KDF internal state used in EAP methods (Table 5).	SP 800-135 KDF	N/A	Internal state of the KDF.
EAP-TLS MSK	Establishment of encrypted session.	Derived from pre-master secret	N/A	At least 512 bits.
EAP-TTLS MSK	Establishment of encrypted session.	Derived from pre-master secret	N/A	At least 512 bits.
EAP-PEAP MSK	Establishment of encrypted session.	Derived from pre-master secret	N/A	At least 512 bits.

7.1 Random Number Generation

The module provides a DRBG compliant with SP800-90A for random number generation and the creation of key components of asymmetric keys. The DRBG implements a CTR_DRBG mechanism with AES-128, AES-192 or AES-256, with selectable enabling of derivation function and prediction resistance. The DRBG is initialized during module initialization and seeded from the NDRNG directly from /dev/hwrng. The NDRNG is provided by the hardware component of the module, which is within the module's logical boundary. The entropy input part of the seed provides at least 256 bits of entropy to the DRBG.

The module performs the health tests for the SP800-90A DRBG as defined per Section 11.3 of SP800-90A. The kernel component performs the continuous test on the NDRNG.

7.2 Key Generation

For generating RSA, DSA, ECDSA, Diffie-Hellman and EC Diffie-Hellman keys, the SummitSSL component of the module implements asymmetric key generation services compliant with FIPS186-4 or SP800-56Arev3 as applicable, and using a DRBG compliant with SP800-90A. The random value used in asymmetric key generation is obtained from the DRBG. In accordance with FIPS 140-2 IG D.12, the cryptographic module performs Cryptographic Key Generation (CKG) for asymmetric keys as per Section 4 of SP800-133rev2 (vendor affirmed).

Symmetric keys are derived from the shared secret established by Diffie-Hellman and EC Diffie-Hellman in a manner that is compliant to NIST SP800-135 for TLS KDF. Symmetric keys can also be derived by means of the IEEE 802.11 protocols CCMP and GCMP, compliant to NIST SP800-108 KDF.

7.3 Key Entry/Output

The module does not support manual key entry or intermediate key generation output. The module does not produce key output outside its physical boundary. The keys are entered to the module in plaintext form via API parameters (data input interface), and output from the module via API output parameters in plaintext (data output interface). Both these operations occur between the module and the calling application only.

7.4 Key/CSP Storage

Public and private keys are provided to the module by the calling process and are destroyed when released by the appropriate API function calls. The module does not perform persistent storage of keys. The only exception is the HMAC key used for integrity test, which is stored in the module's file system. The HMAC key is used solely for the integrity check and cannot be exported from the module or read by user APIs.

7.5 Key/CSP Zeroization

For the SummitSSL component, a general RAM zeroization API is provided:

`sl_DeviceSet(SL_DEVICE_FIPS, SL_DEVICE_FIPS_ZEROIZATION, 0, NULL)`. The API call zeroizes all the RAM, and thus zeroizes all the keys and CSPs.

The kernel component and the hardware component provide two zeroization APIs: `crypto_free_cipher()`, and `crypto_free_aead()`. Both these functions invoke `crypto_free_tfm()`, which will zeroize the context and free the cipher handle.

Zeroization of all keys and CSPs in RAM can also be obtained by powering off the module, and then powering the module back on (power cycle).

The application is responsible for calling the appropriate destruction functions from the SummitSSL API and kernel API. The destruction functions then overwrite the memory occupied by keys with zeros and deallocates the memory with the `free()` call. In case of abnormal termination, the keys in physical memory are overwritten by the kernel before the physical memory is allocated to another process.

7.6 Key Establishment

The module provides Diffie-Hellman and EC Diffie-Hellman shared secret computation compliant with SP800-56Arev3 in accordance with Scenario X1 (1) of IG D.8. In addition, the module offers AES key wrapping per SP800-38F and RSA key wrapping (encapsulation) using public key encryption and private key decryption primitives as allowed by IG D.9. The module provides approved key transport methods according to IG D.9. Even though the module does not implement the GCMP and TLS protocols, the module claims compliance for AES-GCM under IG A.5 under the context of TLS and GCMP usage (Section 10.2.2). As such, there is a scenario under which the AES-GCM algorithm can be used as key transport for an application that implements the GCMP and TLS protocols. Therefore, the module implements the key transport methods by:

- Using an approved key wrapping algorithm (AES-KW, AES-KWP).
- Use of the approved AES-GCM authenticated encryption mode under the context of an application establishing a connection using the wireless protocol GCMP or using a TLS ciphertext with the AES-GCM authenticated encryption mode. Note that in a GCMP connection, the AES-GCM encryption is used.

Table 7 and Table 8 specify the key sizes allowed in the FIPS mode of operation. According to Table 2 in SP800-57, the key sizes of key wrapping, transport, and shared secret computation (using the respective symmetric algorithm, RSA, Diffie-Hellman, and EC Diffie-Hellman) provide the following security strengths:

- AES key wrapping provides between 128 and 256 bits of encryption strength.
- RSA PKCS 1.5 key wrapping provides between 112 and 256 bits of encryption strength.
- Diffie-Hellman shared secret computation provides between 112 and 201 bits of encryption strength.
- EC Diffie-Hellman shared secret computation provides between 112 and 256 bits of encryption strength.
- Use of approved authenticated encryption mode (AES-GCM) within GCMP and TLS. In these contexts, the key establishment methodology provides 128 or 256 bits of encryption strength.

8 Electromagnetic Interference/Electromagnetic Compatibility (EMI/EMC)

The test platforms listed in Table 3 have been tested and found to conform to the EMI/EMC requirements specified by 47 Code of Federal Regulations, FCC PART 15, Subpart B, Unintentional Radiators, Digital Devices, Class B (i.e., Home use). These devices are designed to provide reasonable protection against harmful interference when the devices are operated in a commercial environment.

9 Self-Tests

9.1 Power-Up Self-Tests

The module performs power-up self-tests (POSTs) automatically when the module is powered on. These POSTs ensure that the module is not corrupted and that the cryptographic algorithms work as expected. No operator intervention is necessary to run the POSTs.

While the module is executing the POSTs, services are not available, and input and output are inhibited. The module is not available for use until successful completion of the POSTs.

The integrity of the module's software components (the kernel and the SummitSSL components) is individually verified by the fipscheck integrity test tool using an HMAC-SHA2-256. The HMAC value of each software component is computed at build time and stored in the .hmac file for each component. The value is recalculated at runtime for the image of the kernel and for the SummitSSL binary, and then compared against the stored value in the file. If the comparison succeeds, then the remaining POSTs (consisting of the algorithm-specific Known Answer Tests) for SummitSSL are performed. The kernel component executes its algorithm-specific Known Answer Tests before the fipscheck integrity test tool executes to verify the integrity of the kernel.

On successful completion of all the power-up tests, the module becomes operational and cryptographic services are then available. If any of the tests fails, the module transitions to the error state and subsequent calls to the module will fail. The status of the module can be determined by the availability of the module. If the module is available, then it has passed all self-tests. If the module is unavailable, it is because the POST procedure failed, and the module has transitioned to the error state. Thus, in the error state, no further cryptographic operations will be possible.

Table 11 details the self-tests that are performed on the FIPS-approved cryptographic algorithms supported in the FIPS-approved mode of operation, using the Known-Answer Tests (KATs) and Pairwise Consistency Tests (PCTs).

Table 11: Self-tests.

Algorithm	Test
Kernel and Hardware Components	
AES	<ul style="list-style-type: none"> KAT AES(GCM) with 128-bit key, encryption KAT AES(ECB) with 128-bit key, encryption and decryption
SummitSSL Component	
AES	<ul style="list-style-type: none"> KAT AES(GCM) with 256-bit key, encryption KAT AES(ECB) with 128-bit key, decryption
DSA	<ul style="list-style-type: none"> PCT DSA signature generation and verification with L=2048, N=224 and SHA2-256
RSA	<ul style="list-style-type: none"> KAT RSA PSS signature generation and verification with 2048-bit key SHA2-256
ECDSA	<ul style="list-style-type: none"> PCT ECDSA signature generation and verification with P-224 and K-233, both with SHA2-512
KAS-FFC-SSC (Diffie-Hellman)	<ul style="list-style-type: none"> Primitive "Z" Computation KAT with 2048-bit key
KAS-ECC-SSC (EC Diffie-Hellman)	<ul style="list-style-type: none"> Primitive "Z" Computation KAT with P-224 curve

Algorithm	Test
DRBG	<ul style="list-style-type: none"> KAT CTR_DRBG using AES-256 with and without DF, with and without PR
KBKDF	<ul style="list-style-type: none"> KAT with HMAC-SHA2-256
KDF in TLS v1.0/1.1	<ul style="list-style-type: none"> KAT with HMAC-SHA-1
KDF in TLS v1.2	<ul style="list-style-type: none"> KAT with HMAC-SHA2-256, HMAC-SHA2-384, HMAC-SHA2-512
HMAC	<ul style="list-style-type: none"> KAT HMAC-SHA-1 KAT HMAC-SHA2-256 KAT HMAC-SHA2-512
SHS	<ul style="list-style-type: none"> KAT SHA-1
Module Integrity	<ul style="list-style-type: none"> HMAC-SHA2-256

9.2 Conditional Self-Tests

Conditional tests are performed during operational state of the module when the respective cryptographic functions are used. If any of the conditional tests fails, the module transitions to the error state.

Table 12 lists the conditional self-tests performed by the functions.

Table 12: Conditional self-tests.

Algorithm	Test
DSA Key generation	PCT using SHA2-256, signature generation and verification
ECDSA Key generation	PCT using SHA2-256, signature generation and verification
RSA Key generation	PCT using SHA2-256, signature generation and verification, and for encryption and decryption
NDRNG	Continuous Test (previous and current random data are compared for equality; in which case the test fails)

9.3 On-Demand Self-tests

The module provides the Self-Test service to perform self-tests on demand. On demand self-tests can be invoked by powering-off and powering-on the module. This service performs the same cryptographic algorithm tests executed during power-up. During the execution of the on-demand self-tests, cryptographic services are not available, and no data output or input is possible.

10 Guidance

This section provides guidance for the Crypto Officer and the User to maintain proper use of the module per FIPS 140-2 requirements.

10.1 Crypto-Officer Guidance

Before deploying the module for usage, the Crypto Officer shall employ the following steps:

1. Verify the HMAC values of each component of the module as listed in Table 2.
2. Verify that the kernel component command line is configured to run `fipsInit.sh` before any user mode application or init system.
3. Verify that `'fips=1'` parameter is present on the kernel command line for FIPS mode operation.

10.2 User Guidance

As specified in Section 2.5, the mode of operation of this module is implicitly selected depending upon which security functions or services and key sizes or curves are being used, and the invocation of `FIPS_mode_set(1)` or `FIPS_mode_set(0)` command prior to the cryptographic service.

To run the module in FIPS mode, the user shall follow the rules detailed in Section 2.5 and only use the FIPS approved or allowed services listed in Table 5, or the validated or allowed cryptographic algorithms and security functions listed in Table 7 and Table 8.

10.2.1 Random Number Generator

The SummitSSL API call of `RAND_cleanup` must not be used. This call will clean up the internal DRBG state. This call also replaces the DRBG instance with the non-FIPS Approved libcrypto Deterministic Random Number Generator when using the `RAND*` API calls.

10.2.2 AES GCM IV

AES-GCM encryption and decryption are used in the context of the TLS protocol version 1.2 using the SummitSSL component (corresponding to Scenario 1 of IG A.5), and in the context of IEEE 802.11 GCMP using the kernel/hardware components (corresponding to Scenario 5 of IG A.5).

10.2.2.1 TLS version 1.2

For TLS v1.2, the module uses the context of Scenario 1 of IG A.5. The module is compliant with SP 800-52 and the mechanism for IV generation is compliant with RFC5288. For this compliance, the module's implementation of the AES-GCM shall be used together with an application that negotiates the protocol session's keys and the 32-bit nonce value of the IV. The nonce is considered the "name" field in Scenario 3 of IG A.5. The setting of the counter portion of the IV is performed within the cryptographic boundary.

The nonce explicit part of the IV does not exhaust the maximum number of possible values for a given session key. This condition is implicitly ensured by the design of the TLS protocol, in which the `nonce_explicit` is denied exhaustion by the control exerted by the protocol's management logic (wherein the `nonce_explicit` is incremented per each TLS record). This management logic also implies that the probability of an exhaustion of all $2^{64} - 1$ values of the `nonce_explicit` for the same TLS session in a realistic time frame is not significant.

10.2.2.2 IEEE 802.11 GCMP

For IEEE 802.11 GCMP, the module complies with Scenario 5 of IG A.5 for use of the AES-GCM algorithm within the context of GCMP. The module implements an internal production unit logic that constructs the IV deterministically upon the initialization of a GCMP connection, and therefore the initialization of a GCM encryption context. The 96-bit IV is divided into a 48-bit Transmitter Address field, and a 48-bit Packet Number (PN) field.

The module obtains the Transmitter Address field from the network interface (the wireless network adapter) that is part of the operational environment of the module. This Address field is typically an IEEE 802 Medium Access Control (MAC) address that uniquely identifies the module during the GCMP connection and remains the same value throughout the lifetime of the connection. In Scenario 3 of FIPS 140-2 IG A.5, this Address field corresponds to the "name" field.

The 48-bit Packet Number field is deterministically constructed by the module as a counter field, starting at 1 and strictly incrementing by 1 at each invocation of the GCMP encryption in the context of the GCMP connection. The counter is never allowed to repeat for the same context. If the maximum number of values for the counter is exhausted, the module refuses to offer the GCM encryption service, and thus the GCMP context is aborted. This Packet Number field corresponds to the deterministic non-repetitive counter in Scenario 3 of FIPS 140-2 IG A.5. The combined length from the 48-bit Address field and 48-bit Packet Number forms the GCM IV of 96 bits.

The module also receives the GCM IV from the GCMP layer outside of the boundary of the module and verifies whether the IV as computed by the GCMP layer matches the IV as constructed internally by the module. If there is a mismatch, the module does not allow the GCM encryption service to be provided and the GCMP context is aborted.

To invoke the compliant GCM in the kernel/hardware components, the driver names for encrypt and decrypt are indicated in Table 7.

In case the module's power is lost and then restored, the key used for AES GCM encryption or decryption shall be re-established.

10.2.3 AES-XTS

The AES algorithm in XTS mode can be only used for the cryptographic protection of data on storage devices, as specified in SP800-38E. In addition, the length of a single data unit encrypted with the XTS-AES shall not exceed 2^{20} AES blocks, that is, 16 MiB of data.

In addition, to meet the requirement in A.9, the module implements a check to ensure that the two AES keys used in XTS-AES algorithm are not identical.

10.2.4 Key Usage and Management

In general, a single key shall be used for only one purpose (e.g., encryption, integrity, authentication, key wrapping, random bit generation, or digital signatures) and be disjoint between the modes of operations of the module. Thus, if the module is switched between its FIPS mode and non-FIPS mode or vice versa, the following procedures shall be observed:

- The DRBG engine shall be reseeded.
- CSPs and keys shall not be shared between security functions of the two different modes.

10.3 Handling Self-Test Errors

The module transitions to the error state when any of the self-tests or conditional tests fails in any of the components of the module. In such a case, the module, while in the error state, inhibits output and makes no cryptographic service available. After logging the error, the module then automatically reboots in an attempt to recover from the errors.

Following are the error messages specific to self-test failure as reported by the SummitSSL component:

- FIPS_R_FINGERPRINT_DOES_NOT_MATCH – The integrity verification check failed
- FIPS_R_SELFTEST_FAILED – a known answer test failed
- FIPS_R_TEST_FAILURE – a known answer test failed (RSA); pairwise consistency test failed (DSA)
- FIPS_R_PAIRWISE_TEST_FAILED – a pairwise consistency test failed during DSA, ECDSA or RSA key generation
- FIPS_R_DRBG_STUCK – the DRBG generated two same consecutive values

These errors are reported through the regular ERR interface of the module.

The only way to recover from the error state is through rebooting the module and restarting the application. If failures persist, the module shall be reinstalled. If, after reinstallation, the module still accuses failures, then the module shall be decommissioned.

11 Mitigation of Other Attacks

The vendor does not claim any mitigation of other attacks for this module.

12 Acronyms, Terms and Abbreviations

Term	Definition
AES	Advanced Encryption Standard
CAVP	Cryptographic Algorithm Validation Program
CMVP	Cryptographic Module Validation Program
CSP	Critical Security Parameter
DH	Diffie-Hellman
DHE	Diffie-Hellman Ephemeral
DRBG	Deterministic Random Bit Generator
ECDH	Elliptic Curve Diffie-Hellman
ECDSA	Elliptic Curve Digital Signature Algorithm
HMAC	(Keyed) Hash Message Authentication Code
KAT	Known Answer Test
KDF	Key Derivation Function
NDRNG	Non-Deterministic Random Number generator
NIST	National Institute of Standards and Technology
PAA	Processor Algorithm Acceleration
POST	Power-On Self-Test
PR	Prediction Resistance
PSS	Probabilistic Signature Scheme
PUB	Publication
SHA2	Secure Hash Algorithm
TLS	Transport Layer Security

13 References

- Barker, E., & Roginsky, A. (2015, 11). SP 800-131A Revision 1. Transitions: Recommendation for Transitioning the Use of Cryptographic Algorithms and Key Lengths. National Institute of Standards & Technology. Retrieved from <http://dx.doi.org/10.6028/NIST.SP.800-131Ar1>
- Barker, E., Roginsky, A., & Davis, R. (2020, June). SP 800-133 Rev. 2. Recommendation for Cryptographic Key Generation. *SP 800-133 Rev. 2. Recommendation for Cryptographic Key Generation*. National Institute of Standards & Technology. doi:<https://csrc.nist.gov/publications/detail/sp/800-133/rev-2/final>
- IEEE802.11, Wireless LAN Medium Access Control (MAC) and Physical Layer (PHY) Specifications*. (2016, 8). IEEE.
- National Institute of Standards Technology. (2001, 5 25). FIPS PUB 140-2. Security Requirements for Cryptographic Modules. Retrieved from <https://nvlpubs.nist.gov/nistpubs/FIPS/NIST.FIPS.140-2.pdf>
- National Institute of Standards Technology. (2008, 7). FIPS PUB 198-1. The Keyed-Hash Message Authentication Code (HMAC). Retrieved from http://csrc.nist.gov/publications/fips/fips198-1/FIPS-198-1_final.pdf
- National Institute of Standards Technology. (2012, 3). FIPS PUB 180-4. Secure Hash Standard (SHS). Gaithersburg, MD 20899-8900: National Institute of Standards & Technology. Retrieved from <http://csrc.nist.gov/publications/fips/fips180-4/fips-180-4.pdf>
- National Institute of Standards Technology. (2013, July). FIPS PUB 186-4. Digital Signature Standard (DSS). <https://nvlpubs.nist.gov/nistpubs/fips/nist.fips.186-4.pdf>.
- National Institute of Standards Technology. (2016, 12 21). Annex B: Approved Protection Profiles for FIPS PUB 140-2, Security Requirements for Cryptographic Modules. Retrieved from <https://csrc.nist.gov/CSRC/media/Publications/fips/140/2/final/documents/fips1402annexa.pdf>
- National Institute of Standards Technology. (2019, August 16). *Implementation Guidance for FIPS 140-2 and the Cryptographic Module Validation Program*. Retrieved August 27, 2019, from <https://csrc.nist.gov/csrc/media/projects/cryptographic-module-validation-program/documents/fips140-2/fips1402ig.pdf>